

# Type 462

Safety Relief Valves  
– spring loaded

Metric Units



## Facts

**LESER**

The-Safety-Valve.com

## Available designs

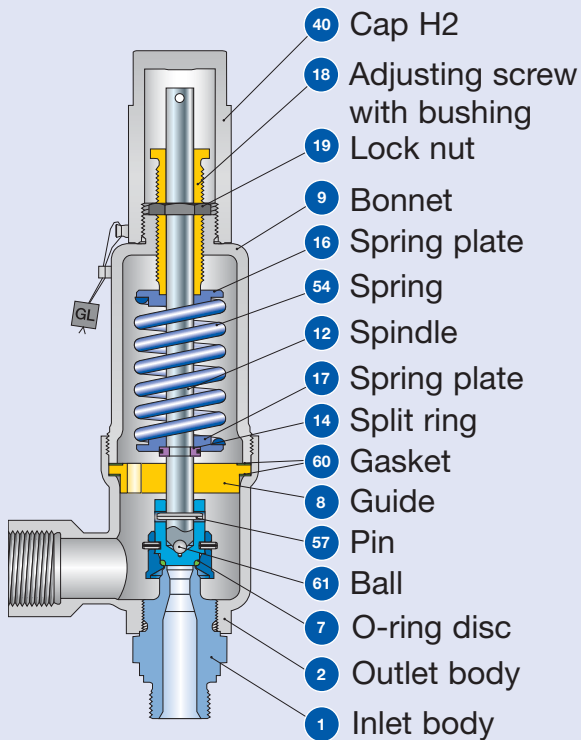

**Conventional design**  
Threaded connection

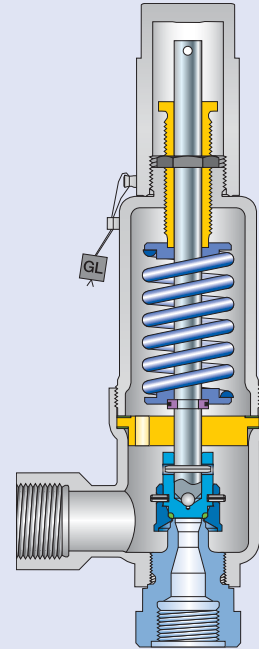

**Conventional design**  
Threaded connection

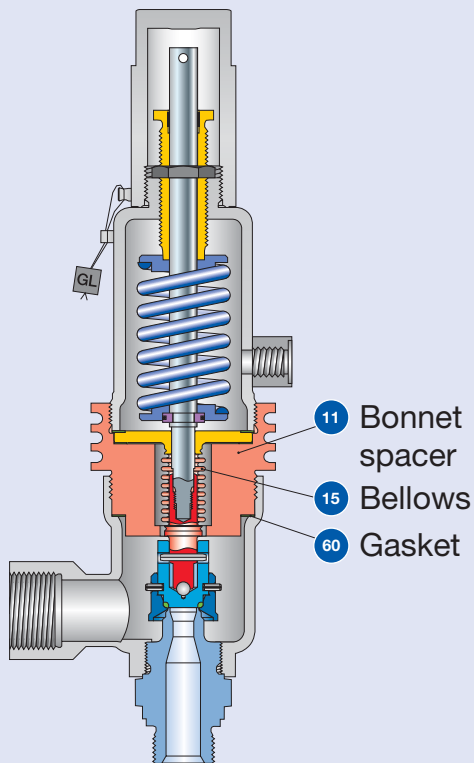

**Balanced bellows**  
Threaded connection

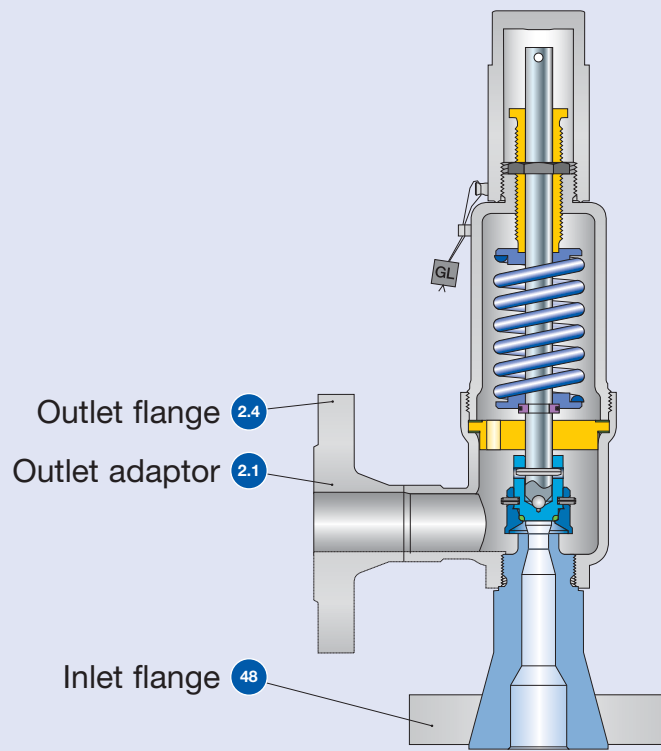

**Conventional design**  
Flange connection

## Available designs – materials

Materials					
Item	Component	Remarks	Type 4623	Type 4622	Type 4624
1	Base / Inlet body	Threaded connection	1.4104	1.4404 SA 479 316L	1.4404 SA 479 316L
		Flange connection	1.4404 SA 479 316L	1.4404 SA 479 316L	1.4404 SA 479 316L
2	Outlet body		0.7043 Ductile Gr. 60-40-18	1.0619 WCB	1.4404 or 1.4408 SA 479 316L or CF8M
2.1	Outlet adaptor	Flange connection	1.4404 316L	1.4404 316L	1.4404 316L
2.4	Outlet flange	Flange connection	1.4404 316L	1.4404 316L	1.4404 316L
7	O-ring disc		1.4404 SA 479 316L	1.4404 SA 479 316L	1.4404 SA 479 316L
			NBR Nitrile-Butadiene	NBR Nitrile-Butadiene	NBR Nitrile-Butadiene
7.4	Soft seal O-ring	"K"	CR Chloroprene	CR Chloroprene	CR Chloroprene
		"D"	EPDM Ethylen-Propylene-Diene	EPDM Ethylen-Propylene-Diene	EPDM Ethylen-Propylene-Diene
		"L"	FPM Fluorocarbon	FPM Fluorocarbon	FPM Fluorocarbon
		"C"	FFKM Perflouro	FFKM Perflouro	FFKM Perflouro
			1.4104 tenifer Chrome steel tenifer	1.4104 tenifer Chrome steel tenifer	1.4404 316L
8	Guide		1.4404 / SA 316L	1.4404 / SA 316L	1.4404 / SA 316L
		Balanced bellows design	Upper connection of balanced bellows	Upper connection of balanced bellows	Upper connection of balanced bellows
9	Bonnet		0.7043 Ductile Gr. 60-40-18	1.0460 Carbon steel	1.4404 316L
		Balanced bellows design	1.4404 316L	1.4404 316L	1.4404 316L
11	Bonnet spacer	Balanced bellows design	1.4404 316L	1.4404 316L	1.4404 316L
12	Spindle		1.4021 420	1.4404 316L	1.4404 316L
		Balanced bellows design	1.4404 316L	1.4404 316L	1.4404 316L
14	Split ring		1.4104 Chrome steel	1.4104 Chrome steel	1.4404 316L
		Balanced bellows design	1.4571 316Ti	1.4571 316Ti	1.4571 316Ti
15	Bellows		1.0718 Steel	1.0718 Steel	1.4404 316L
16/17	Spring plate		1.4104 / PTFE Chrome steel / PTFE	1.4104 / PTFE Chrome steel / PTFE	1.4104 / PTFE Chrome steel / PTFE
18	Adjusting screw with bushing		1.4104 430	1.4104 430	1.4404 316L
			1.0718 Steel	1.0718 Steel	1.4404 316L
48	Inlet flange	Flange connection	1.4404 316L	1.4404 316L	1.4404 316L
			1.1200 / 1.8159 / 1.7107 Carbon steel	1.1200 / 1.8159 / 1.7107 Carbon steel	1.4310 Stainless steel
54	Spring	Standard	1.4310 Stainless steel	1.4310 Stainless steel	-
		Optional	1.4310 Stainless steel	1.4310 Stainless steel	-
57	Pin		1.4310 Stainless steel	1.4310 Stainless steel	1.4310 Stainless steel
60	Gasket		Graphite / 1.4401 Graphite / 316	Graphite / 1.4401 Graphite / 316	Graphite / 1.4401 Graphite / 316
			1.3541 Hardened stainless steel	1.3541 Hardened stainless steel	1.4401 316
61	Ball				

**Please notice:**

- Modifications reserved by LESER.
- LESER can upgrade materials without notice.
- Every part can be replaced by other material acc. to customer specification.

## How to order – Article numbers

Article numbers							
<b>O-ring material</b>				NBR	"N"	J30	
				CR	"K"	J21	
				EPDM	"D"	J22	
				FKM	"L"	J23	
				FFKM	"C"	J20	
Actual Orifice diameter $d_0$ [mm]			9	13	17,5		
Actual Orifice area $A_0$ [mm <sup>2</sup> ]			63,9	133	241		
Actual Orifice diameter $d_0$ [inch]			0,354	0,512	0,689		
Actual Orifice area $A_0$ [inch <sup>2</sup> ]			0,099	0,206	0,374		
Outlet chamber casted							
<b>Inlet body</b>	<b>1.4104</b>	<b>H2</b>	Art.-No. <b>4623.</b>	<b>2902</b>	<b>2912</b>	<b>2922</b>	
<b>Outlet body</b>	<b>0.7043</b>	<b>H3</b>	Art.-No. <b>4623.</b>	<b>2903</b>	<b>2913</b>	<b>2923</b>	
<b>Bonnet</b>	<b>0.7043</b>	<b>H4</b>	Art.-No. <b>4623.</b>	<b>2904</b>	<b>2914</b>	<b>2924</b>	
p [bar <sub>g</sub> ]		S/G/L		<b>0,5 – 250</b>	<b>0,5 – 180</b>	<b>0,5 – 92,5</b>	
p [psig]				<b>7,3 – 3626</b>	<b>7,3 – 2911</b>	<b>7,3 – 1342</b>	
Outlet chamber deep-drawn							
<b>Inlet body</b>	<b>1.4404</b>	<b>H2</b>	Art.-No. <b>4622.</b>	<b>3772</b>	<b>3782</b>	<b>3792</b>	
<b>Outlet body</b>	<b>1.4404</b>	<b>H3</b>	Art.-No. <b>4622.</b>	<b>3773</b>	<b>3783</b>	<b>3793</b>	
<b>Bonnet</b>	<b>1.0460</b>	<b>H4</b>	Art.-No. <b>4622.</b>	<b>3774</b>	<b>3784</b>	<b>3794</b>	
p [bar <sub>g</sub> ]		S/G/L		<b>0,5 – 250</b>	<b>0,5 – 180</b>	<b>0,5 – 92,5</b>	
p [psig]				<b>7,3 – 3626</b>	<b>7,3 – 2611</b>	<b>7,3 – 1342</b>	
Outlet chamber casted							
<b>Inlet body</b>	<b>1.4404</b>	<b>H2</b>	Art.-No. <b>4624.</b>	<b>2162</b>	<b>2172</b>	<b>2182</b>	
<b>Outlet body</b>	<b>1.4408</b>	<b>H4</b>	Art.-No. <b>4624.</b>	<b>2164</b>	<b>2174</b>	<b>2184</b>	
p [bar <sub>g</sub> ]		S/G/L		<b>0,5 – 250</b>	<b>0,5 – 180</b>	<b>0,5 – 92,5</b>	
p [psig]				<b>7,3 – 3626</b>	<b>7,3 – 2611</b>	<b>7,3 – 1342</b>	
Outlet chamber deep-drawn							
<b>All body and trim parts</b>	<b>1.4404</b>	<b>H2</b>	Art.-No. <b>4624.</b>	<b>2952</b>	<b>2962</b>	<b>2972</b>	
		<b>H4</b>	Art.-No. <b>4624.</b>	<b>2954</b>	<b>2964</b>	<b>2974</b>	
p [bar <sub>g</sub> ]		S/G/L		<b>0,5 – 250</b>	<b>0,5 – 180</b>	<b>0,5 – 92,5</b>	
p [psig]				<b>7,3 – 3626</b>	<b>7,3 – 2611</b>	<b>7,3 – 1342</b>	

For selection of inlet and outlet connection please refer to page 09/06 – 09/07.

## Dimensions and weights – Metric Units

### Threaded connections

Size Outlet body		1"	1"	1"	1"	1"	1"	1 1/2"	1 1/2"	1 1/2"	1 1/2"	1 1/2"	
Actual Orifice diameter $d_0$ [mm]		9	9	9	13	13	13	17,5	17,5	17,5	17,5	17,5	
Actual Orifice area $A_0$ [mm <sup>2</sup> ]		63,6	63,6	63,6	133	133	133	241	241	241	241	241	
<b>Weight</b>	Standard [kg]	2,6	2,6	2,6	2,6	2,6	2,6	3,0	3,0	3,0	3,0	3,0	
	Balanced bellows	3,4	3,4	3,4	3,4	3,4	3,4	3,8	3,8	3,8	3,8	3,8	
Required installation diameter [mm]		165	165	165	165	165	165	165	165	165	165	165	
<b>Inlet thread "Female"</b>													
<b>DIN ISO 228-1</b>	<b>G</b>	Inlet a	60,5	65,5	70	60,5	65,5	70,5	65,5	70,5	75,5	80,5	–
		Center to face [mm]	Outlet b	75	75	75	75	75	75	75	75	75	75
Height	[mm]	H max.	290,5	295,5	300,5	290,5	295,5	300,5	292,5	297,5	302,5	307,5	–
<b>ISO 7-1/BS 21</b>	<b>Rc</b>	Inlet a	60,5	70,5	70,5	60,5	70,5	70,5	70,5	70,5	–	–	–
		Center to face [mm]	Outlet b	75	75	75	75	75	75	75	75	–	–
Height	[mm]	H max.	290,5	300,5	300,5	290,5	300,5	300,5	297,5	297,5	–	–	–
<b>ANSI/ASME B1.20.1</b>	<b>NPT</b>	Inlet a	60,5	70,5	70,5	60,5	70,5	70,5	70,5	70,5	75,5	80,5	–
		Center to face [mm]	Outlet b	75	75	75	75	75	75	75	75	75	75
Height	[mm]	H max.	290,5	300,5	300,5	290,5	300,5	300,5	297,5	297,5	302,5	307,5	–
<b>Inlet thread "Male"</b>													
<b>DIN ISO 228-1</b>	<b>G</b>	Inlet a	–	55,5	55,5	–	55,5	55,5	55,5	55,5	55,5	55,5	–
		Center to face [mm]	Outlet b	–	75	75	–	75	75	75	75	75	75
<b>ISO 7-1/BS 21</b>	<b>R</b>	Inlet a	–	52,5	52,5	–	52,5	52,5	–	52,5	–	52,5	–
		Center to face [mm]	Outlet b	–	75	75	–	75	75	–	75	–	75
<b>ANSI/ASME B1.20.1</b>	<b>NPT</b>	Inlet a	–	52,5	52,5	–	52,5	52,5	–	52,5	52,5	52,5	53
		Center to face [mm]	Outlet b	–	75	75	–	75	75	–	75	75	75

### Height inlet thread "Male"

Inlet thread		Conventional design							Balanced bellows					
		Size	1/2"	3/4"	1"	1 1/4"	1 1/2"	2"	1/2"	3/4"	1"	1 1/4"	1 1/2"	2"
DIN ISO 228-1	[mm] <b>G</b>	H max.	–	301,5	303,5	302,5	304,5	–	–	346,5	348,5	347,5	349,5	–
ISO 7-1/BS 21	[mm] <b>R</b>	H max.	–	302,5	305,5	–	307,5	–	–	347,5	350,5	–	352,5	–
ASME B1.20.1	[mm] <b>NPT</b>	H max.	–	304,5	309,5	307,5	307,5	308	–	349,5	354,5	352,5	352,5	353

### Length of screwed end "c" inlet thread "Male"

Inlet thread		Size	1/2"	3/4"	1"	1 1/4"	1 1/2"	2"
DIN ISO 228-1	[mm] <b>G</b>		14	16	18	20	22	–
ISO 7-1/BS 21	[mm] <b>R</b>		19	20	23	–	28	–
ASME B1.20.1	[mm] <b>NPT</b>		22	22	27	28	28	28

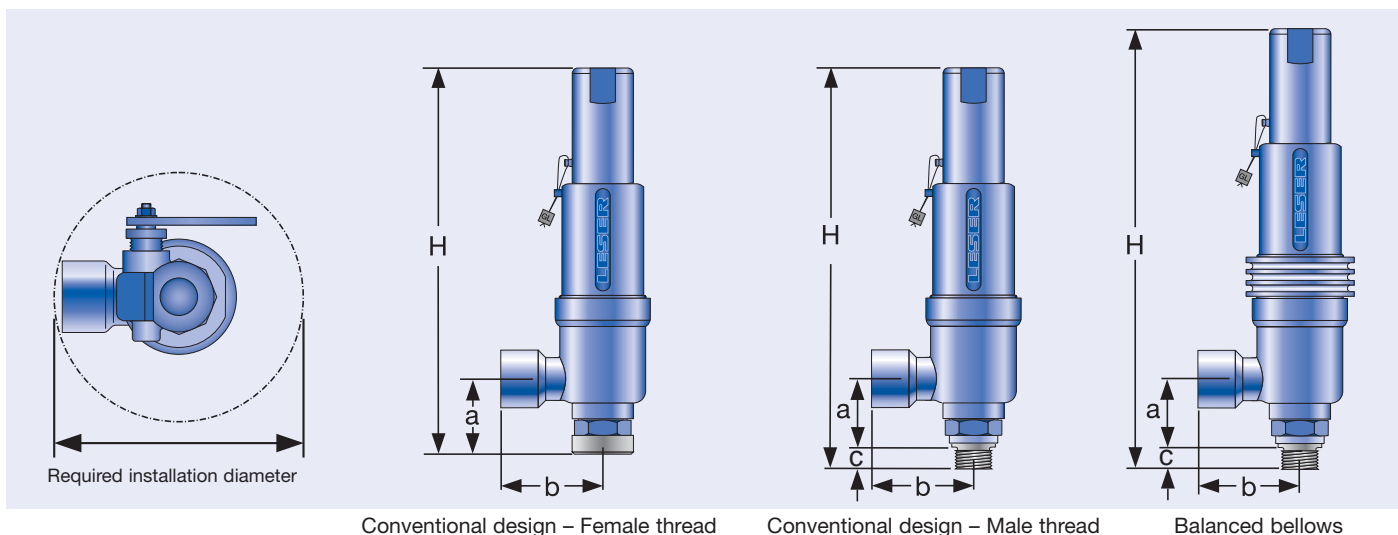

## Dimensions and weights – Metric Units

### Flanged connection

	Conventional design			Balanced bellows		
Actual Orifice diameter $d_0$ [mm]	9	13	17,5	9	13	17,5
Actual Orifice area $A_0$ [mm <sup>2</sup> ]	63,6	133	241	63,6	133	241

DIN ISO 1092-1 (Available flange sizes refer to page 09/07)

#### Flange rating PN 40 – 400

Center to face [mm]	Inlet a	Conventional design			Balanced bellows		
		100	100	105	100	100	105
	Outlet b	100	100	100	100	100	
Height [H4] [mm]	H max.	330	330	333	375	375	378

ASME B 16.5 (Available flange sizes refer to page 09/07)

#### Flange rating class 150 – 2500

Center to face [mm]	Inlet a	Conventional design			Balanced bellows		
		100	100	105	100	100	105
	Outlet b	100	100	100	100	100	
Height [H4] [mm]	H max.	330	330	333	375	375	378

#### Weight

For the calculation of the total weight please use the Formular:  $W_T = W_N + W_F(\text{Inlet}) + W_F(\text{Outlet})$

Weight net [kg] (without inlet and outlet flange) $W_N$	Conventional design			Balanced bellows		
	2,6	2,6	3	3,8	3,8	4,2

### Flange dimensions and availability

	Size	DIN ISO 1092-1 / Flange rating PN					ASME B16.5 / Flange rating class					
		40	160	250	320	400	Size	150	300	600	900	1500
<b>DN 15</b>							<b>NPS 1/2"</b>					
Flange thickness [mm] s		18	22	26	26	30		14	18		26	30,2
Weight slip on flange [kg] $W_F$		0,8	1,2	2,5	2,5	3,6		0,6	0,9		2,1	3
Available at Inlet		✓	✓	✓	✓	✓		✓	✓		✓	✓
Available at Outlet		✓	✓	✓				✓	✓		✓	
<b>DN 20</b>							<b>NPS 3/4"</b>					
Flange thickness [mm] s		20	22					15	18		25,4	32
Weight slip on flange [kg] $W_F$		1,1	1,3					0,8	1,4		2,3	3,5
Available at Inlet		✓	✓					✓	✓		✓	✓
Available at Outlet		✓	✓					✓	✓		✓	
<b>DN 25</b>							<b>NPS 1"</b>					
Flange thickness [mm] s		22	26	30	36	40		17	21,5		32,5	40
Weight slip on flange [kg] $W_F$		1,3	2,6	3,5	5	7,5		1	2,1		4,1	5,1
Available at Inlet		✓	✓	✓	✓	✓		✓	✓		✓	✓
Available at Outlet		✓	✓	✓				✓	✓		✓	
<b>DN 40</b>							<b>NPS 1 1/2"</b>					
Flange thickness [mm] s		23	23	34				22	24		38	
Weight slip on flange [kg] $W_F$		2,1	2,9	4,3				1,4	2,2		3,9	
Available at Inlet		✓	✓	✓				✓	✓		✓	
Available at Outlet		✓	✓	✓				✓	✓		✓	

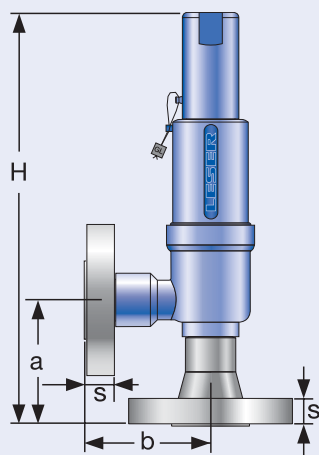

Conventional design

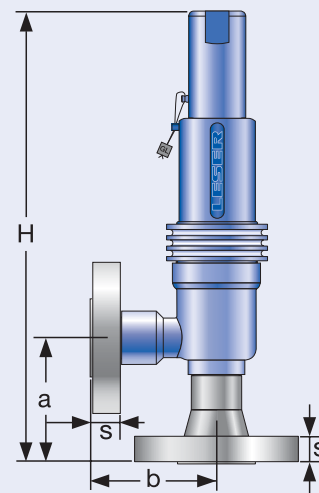

Balanced bellows

## Pressure temperature ratings – Metric Units

Metric Units												
Actual Orifice diameter $d_0$ [mm]		9			13			17,5				
Actual Orifice Area $A_0$ [mm <sup>2</sup> ]		63,6			133			241				
Body material: 1.4104 (430F)						Type 4623						
Base / Inlet Body	Connection size	1/2"	3/4"	1"	1/2"	3/4"	1"	3/4"	1"	1 1/4"	1 1/2"	2"
	Pressure rating	PN 400			PN 250			PN 160				
Outlet body	Pressure rating	PN 40			PN 40			PN 40				
Minimum set pressure	p [bar <sub>g</sub> ] S/G/L	0,5			0,5			0,5				
Min. set pressure <sup>1)</sup> standard bellows	p [bar <sub>g</sub> ] S/G/L	40			40			40				
Min. set pressure low press. bellows	p [bar <sub>g</sub> ] S/G/L	3			3			3				
Maximum set pressure	p [bar <sub>g</sub> ] S/G/L	250			180			92,5				
Temperature acc. to DIN EN	min [°C]				-10							
	max [°C]				+350							
Temperature acc. to ASME	min [°C]				-29							
	max [°C]				+150							
Body material: 1.4404 (316L)						Type 4622						
Base / Inlet Body	Connection size	1/2"	3/4"	1"	1/2"	3/4"	1"	3/4"	1"	1 1/4"	1 1/2"	2"
	Pressure rating	PN 250			PN 160			PN 160				
Outlet Body	Pressure rating	PN 40			PN 40			PN 40				
Minimum set pressure	p [bar <sub>g</sub> ] S/G/L	0,5			0,5			0,5				
Min. set pressure <sup>1)</sup> standard bellows	p [bar <sub>g</sub> ] S/G/L	40			40			40				
Min. set pressure low press. bellows	p [bar <sub>g</sub> ] S/G/L	3			3			3				
Maximum set pressure	p [bar <sub>g</sub> ] S/G/L	250			180			92,5				
Temperature acc. to DIN EN	min [°C]				-45							
	max [°C]				+180							
Temperature acc. to ASME	min [°C]				-45							
	max [°C]				+180							
Body material: 1.4404 (316L)						Type 4624						
Base / Inlet Body	Connection size	1/2"	3/4"	1"	1/2"	3/4"	1"	3/4"	1"	1 1/4"	1 1/2"	2"
	Pressure rating	PN 250			PN 160			PN 160				
Outlet Body	Pressure rating	PN 40			PN 40			PN 40				
Minimum set pressure	p [bar <sub>g</sub> ] S/G/L	0,5			0,5			0,5				
Min. set pressure <sup>1)</sup> standard bellows	p [bar <sub>g</sub> ] S/G/L	40			40			40				
Min. set pressure <sup>1)</sup> standard bellows	p [bar <sub>g</sub> ] S/G/L	3			3			3				
Maximum set pressure	p [bar <sub>g</sub> ] S/G/L	250			180			92,5				
Temperature acc. to DIN EN	min [°C]				-45							
	max [°C]				+150							
Temperature acc. to ASME	min [°C]				-268							
	max [°C]				+150							

<sup>1)</sup> Min. set pressure standard bellows = Max. pressure low pressure bellows.  
The temperature is limited by soft seal material. The stated values are valid for EPDM.

## Available Options

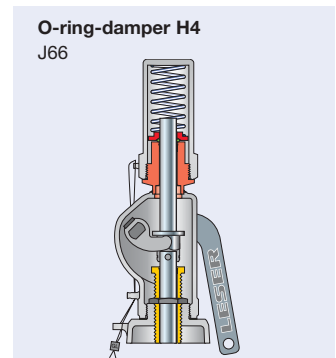
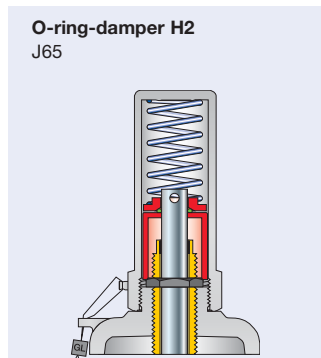
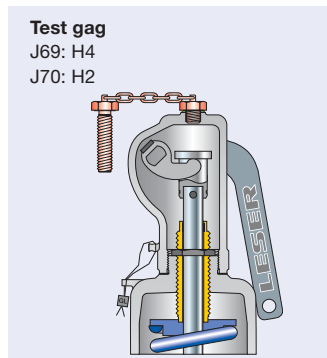
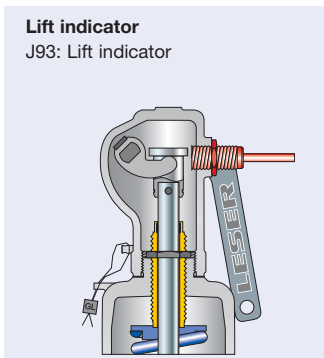
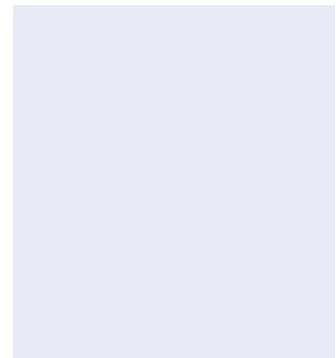
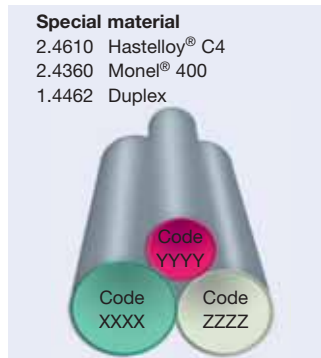
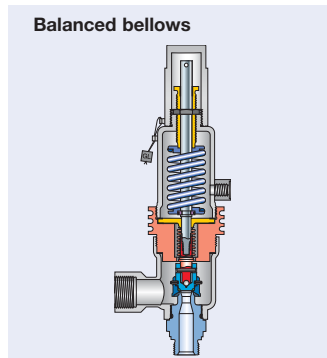
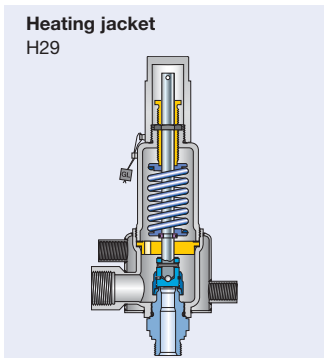
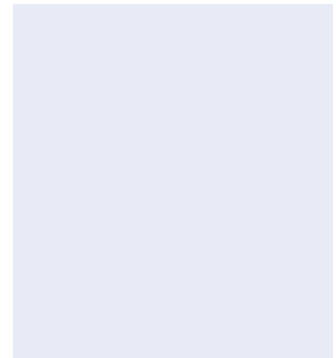
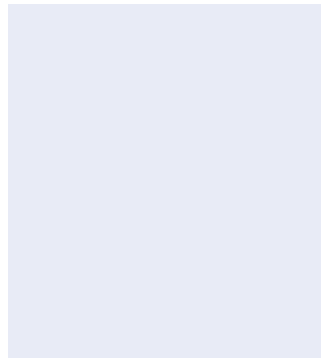
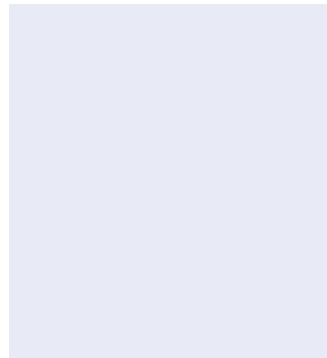
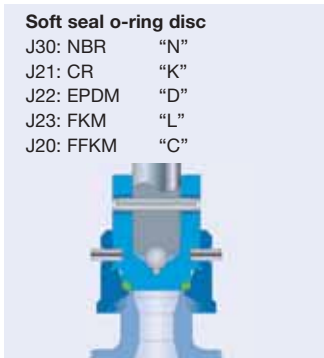
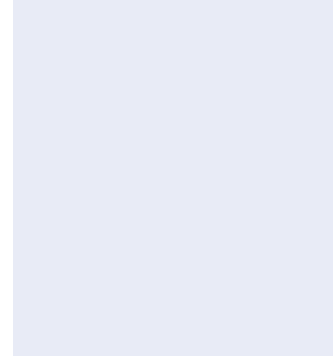
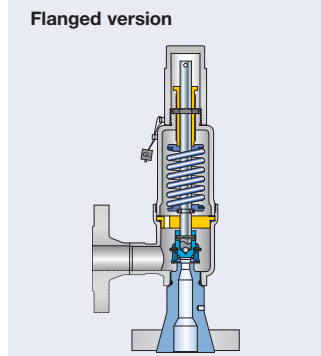
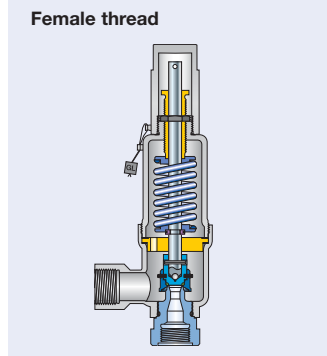
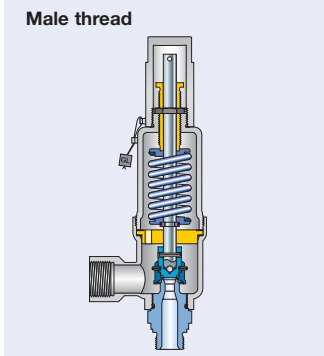



## Available connections

For dimensions and weights refer to:  
 Type 459 – page 05/08 + 05/10  
 Type 459 HDD – page 06/08 + 06/10  
 Type 462 – page 07/08 + 07/10  
 Type 462 HDD – page 08/08 + 08/10

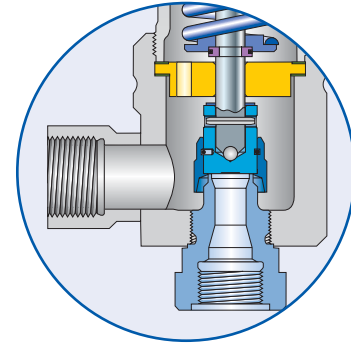
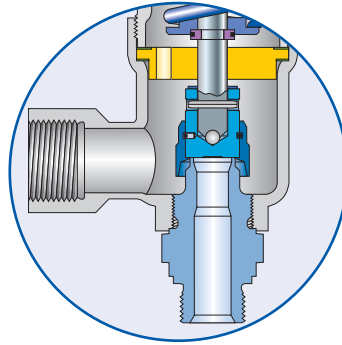

Male thread

Female thread

### Threaded connections

Actual Orifice diameter $d_0$ [mm]		6		9 / 13		17,5	
Actual Orifice area $A_0$ [mm <sup>2</sup> ]		28,3		63,9 / 133		241	
Actual Orifice diameter $d_0$ [inch]		0,236		0,345 / 0,512		0,689	
Actual Orifice area $A_0$ [inch <sup>2</sup> ]		0,044		0,099 / 0,206		0,374	
Valve size	Inlet	Outlet	Inlet	Outlet	Inlet	Outlet	Outlet
<b>Male thread DIN ISO 228-1</b>							
G	1/2"	V54	–	–	–	–	–
	3/4"	V55	–	V55	–	–	–
	1"	V56	V68	V56	V68	V65	–
	1 1/4"	–	V79	–	V79	V83	V79
	1 1/2"	–	V69	–	V69	V57	V69
<b>Female thread DIN ISO 228-1</b>							
G	1/2"	V50	–	V50	–	–	–
	3/4"	V51	–	V51	–	V51	–
	1"	V52	V66	V52	V66	V52	–
	1 1/4"	–	V81	–	V81	V84	V81
	1 1/2"	–	V67	–	V67	V53	V67
<b>Male thread DIN ISO 7-1/BS 21</b>							
R/BSPT	1/2"	V30	–	–	–	–	–
	3/4"	V31	–	V31	–	–	–
	1"	V32	V42	V32	V42	V32	–
	1 1/2"	–	V43	–	V43	V33	V43
<b>Female thread DIN ISO 7-1/BS 21</b>							
Rc/BSPT	1/2"	V38	–	V38	–	–	–
	3/4"	V39	–	V39	–	V39	–
	1"	V40	V36	V40	V36	V40	–
	1 1/2"	–	V37	–	V37	V41	V37
<b>Male thread ANSI/ASME B1.20.1</b>							
NPT	1/2"	V61	–	–	–	–	–
	3/4"	V62	–	V62	–	–	–
	1"	V63	V73	V63	V73	V63	–
	1 1/4"	–	V82	–	V82	V85	V82
	1 1/2"	–	V74	–	V74	V64	V74
	2"	–	–	–	–	–	V86
<b>Female thread ANSI/ASME B1.20.1</b>							
NPT	1/2"	V58	–	V58	–	–	–
	3/4"	V59	–	V59	–	V59	–
	1"	V60	V71	V60	V71	V60	–
	1 1/4"	–	V80	–	V80	V87	V80
	1 1/2"	–	V72	–	V72	V75	V72
	2"	–	–	–	–	–	–

Flanged and threaded connections can be combined.  
 Threads according to other standards are available.  
 Please specify in writing (diameter, pressure rating, standard).

## Available connections

For dimensions and weights refer to:  
 Type 459 – page 05/09 + 05/11  
 Type 459 HDD – page 06/09 + 06/11  
 Type 462 – page 07/09 + 07/11  
 Type 462 HDD – page 08/09 + 08/11

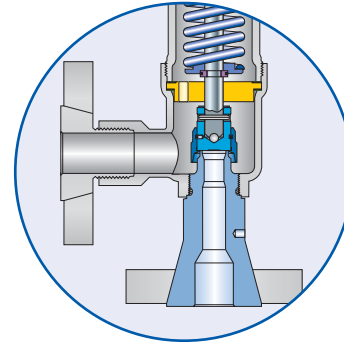

### Flanged connections

### Flanged version

Actual Orifice diameter $d_0$ [mm]	<b>6</b>	<b>9 / 13</b>	<b>17,5</b>
Actual Orifice area $A_0$ [mm <sup>2</sup> ]	28,3	63,9 / 133	241
Actual Orifice diameter $d_0$ [inch]	0,236	0,345 / 0,512	0,689
Actual Orifice area $A_0$ [inch <sup>2</sup> ]	0,044	0,099 / 0,206	0,374

### DIN ISO 1092-1 (PN > 100: DIN 2501)

	PN	Inlet	Outlet	Inlet	Outlet	Inlet	Outlet
DN 15	40	I21	–	I21	–	–	–
	160	I22	–	I22	–	–	–
	250	I23	–	I23	–	–	–
	320	I24	–	I24	–	–	–
	400	I25	–	I25	–	–	–
DN 20	40	I26	–	I26	–	I26	–
	160	I27	–	I27	–	I27	–
	250	–	–	–	–	–	–
	320	–	–	–	–	–	–
	400	–	–	–	–	–	–
DN 25	40	I31	I46	I31	I46	I31	–
	160	I32	I47	I32	I47	I32	–
	250	I33	I48	I33	I48	I33	–
	320	I34	–	I34	–	I34	–
	400	I35	–	I35	–	I35	–
DN 40	40	–	–	–	I49	–	I49
	320	–	–	–	I50	–	I50
	400	–	–	–	I51	–	I51

### ANSI/ASME B 16.5

	Class	Inlet	Outlet	Inlet	Outlet	Inlet	Outlet
NPS 1/2"	150	V01	–	V01	–	–	–
	300	V02	–	V02	–	–	–
	600	V02	–	V02	–	–	–
	900	V03	–	V03	–	–	–
	1500	V03	–	V03	–	–	–
	2500	V04	–	V04	–	–	–
NPS 3/4"	150	V05	–	V05	–	V05	–
	300	V06	–	V06	–	V06	–
	600	V06	–	V06	–	V06	–
	900	V07	–	V07	–	V07	–
	1500	V07	–	V07	–	V07	–
	2500	V08	–	V08	–	V08	–
NPS 1"	150	V09	V18	V09	V18	V09	–
	300	V10	V19	V10	V19	V09	–
	600	V10	V19	V10	V19	V10	–
	900	V11	V20	V11	V20	V10	–
	1500	V11	–	V11	–	V11	–
	2500	V12	–	V12	–	V12	–
NPS 1 1/2"	150	–	–	–	V21	–	V21
	300	–	–	–	V22	–	V22
	600	–	–	–	V22	–	V22
	900	–	–	–	V23	–	V23

Flanged and threaded connections can be combined. Threads according to other standards are available. Please specify in writing (diameter, pressure rating, standard).