

## GESTRA Steam Systems

Product Range A2

Non-Return Valve

**RK 26A**

**For Flanges PN 10/16/25/40, DN 15-100**

**ASME Class 150/300**

**RK 26A**

### Description

Wafer-type non-return (check) valve for sandwiching between flanges. Valve with spring for installation in any position. Without spring only for vertical lines with upward flow. Self-centering valve body ensures accurate installation. Application for liquids, gases and vapours. Please observe the classification according to the Pressure Equipment Directive (PED).

### Pressure / Temperature Rating

RK 26A	DIN, EN, ASME B16.5, Class 300										Design	
	[°C]	-200	20	100	200	300	350	400	450	500		550
DN 15 – 200 [bar] g		49.6	49.6	42.2	35.7	31.6						metal-to-metal (standard)
		49.6	49.6	42.2	35.7	31.6	30.3	29.4	28.8	28.2	25.0	metal-to-metal with Nimonic® springs

Valve disc gasket	t <sub>min</sub> [°C]	t <sub>max</sub> [°C]	Application	Leakage rate
Metal-to-metal RK 26A, DN 15-100	-200	550	Liquids, gases, vapours	EN 12266-1, Class C
PTFE	-190	250	Corrosive fluids	EN 12266-1, Class C
EPDM	-40	150	Water, condensate, vapours	EN 12266-1, Class A
FPM	-25	200	Mineral oils, gases, air	EN 12266-1, Class A

Please check the chemical suitability of the valve for the application in question or, if in doubt, consult us.

### End Connections

DIN <sup>1)</sup>	ASME	BS 10
EN 1092-1 PN 10/16/25/40 Groove/groove Female/female	B 16.1 Class 125 FF B 16.5 Class 150/300 RF Ring Joint Facing (optional)	Table D, E, F, H, J

<sup>1)</sup> Please order DN 100 for PN 6/16 or PN 25/40

### Dimensions

Valve size	[mm]	15	20	25	32	40	50	65	80	100
	[inch]	½	¾	1	1¼	1½	2	2½	3	4
Face-to-face dimensions [mm]	L <sup>2)</sup>	25	31.5	35.5	40	45	56	63	71	80
∅ D	PN 10/16	52	63	72	81	93	108	128	143	163
	PN 25	52	63	72	81	93	108	128	143	169
	PN 40	52	63	72	81	93	108	128	143	169
	Class 150 RF	46	56	66	75	85	104	123	135	173
	Class 300 RF	52	63	72	81	93	108	128	147	179
Weight	[kg]	0.25	0.4	0.57	0.83	1.2	2.15	3.2	4.5	6.9

<sup>2)</sup> Short overall length according to EN 558-2, series 52 (≙ DIN 3202-3, series K5)

### Materials

DN 15-100		DIN/EN	ASTM	Category
Body, seat and guide ribs	RK 26A	1.4408	A 351CF8M	Stainless steel
Valve disc, spring retainer		1.4571		Stainless steel
Spring				Stainless steel

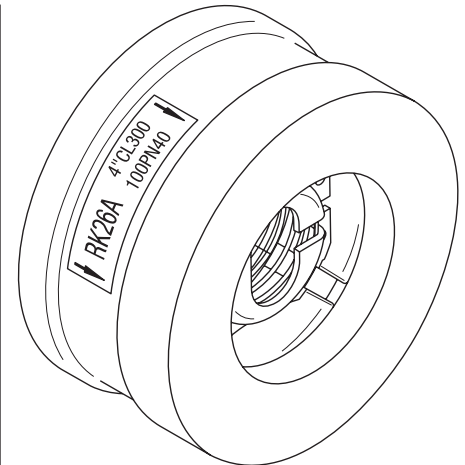

DN 15-100  
Optional: with connection for electrostatic discharge line

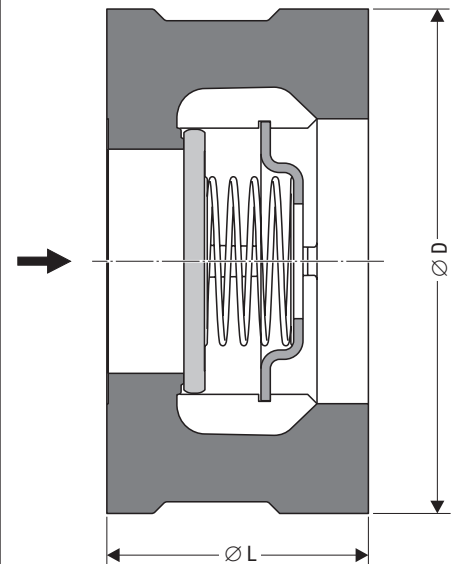

## Non-Return Valve

### RK 26A

For Flanges PN 10/16/25/40,  
DN 15-100, ASME Class 150/300

### Opening Pressures

Differential pressures at zero volume flowrate

DN	Opening pressures [mbar]			
	without spring	Direction of flow in valve		
		↑	→	↓
15	2.5	10	7.5	5
20	2.5	10	7.5	5
25	2.5	10	7.5	5
32	3.5	12	8.5	5
40	4.0	13	9	5
50	4.5	14	9.5	5
65	5.0	15	10	5
80	5.5	16	10.5	5
100	6.5	18	11.5	5

On request at extra charge, special springs for opening pressures:

Between 5 and 1000 mbar for DN 15 – 50 mm,  
between 5 and 700 mbar for DN 65 and 80,  
between 5 and 500 mbar for DN 100.

### Enquiry Specification

GESTRA DISCO Non-return valve type RK 26 A for flanges PN 10/16/25/40.

Wafer design with extremely short overall length to EN 558-2, series 52.

Suitable for fitting between pipe flanges to DIN/EN, BS and ASME. Self-centering valve body. The valve disc rests on two of the four guide ribs, independently of the flange standard. Broad sealing surfaces. Installation in any position. Optional connection for electrostatic discharge line. Stronger springs for other opening pressures are also available on request. Metal-to-metal or soft (EPDM, FPM) seats. Design in accordance with PED 97/23/CE, with CE marking. Specification of nominal pressure, size, body materials etc. in accordance with EN 19.

### Please note:

The selected non return valve must ensure that the minimum volume flowrate keeps the valve disk in the open position (see Pressure Drop Chart / stable range). Valve construction is very robust, but they are not recommended for use on compressors or where pulsating flow exists. If in doubt please consult us and we will carry out the pressure drop calculation and select a suitable valve.

Supply in accordance with our general terms of business.

### Pressure Drop Chart

The curves given in the chart are valid for water at 20 °C. To read the pressure drop for other fluids the equivalent water volume flowrate must be calculated and used in the graph.

The values indicated in the chart are applicable to spring-loaded valves with horizontal flow. With vertical flow insignificant deviations occur only within the range of partial opening.

$$\dot{V}_w = \dot{V} \cdot \sqrt{\frac{\rho}{1000}}$$

$\dot{V}_w$  = Equivalent water volume flow in [l/s] or [m³/h]

$\rho$  = Density of fluid (operating condition) in [kg/m³]

$\dot{V}$  = Volume of fluid (operating condition) in [l/s] or [m³/h]

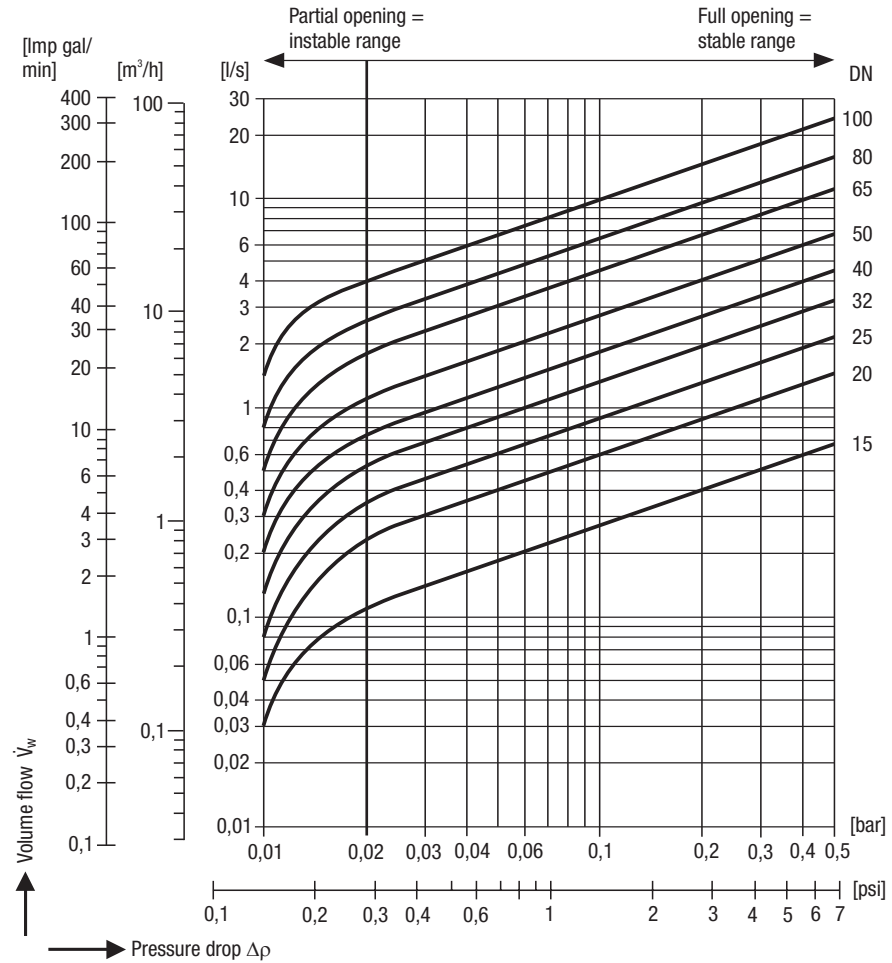

### When ordering please state:

Fluid, flowrate, service pressure and temperature, standard of pipe flange.

### The following test certificates can be issued on request, at extra cost:

In accordance with EN 10204-2.1, -2.2, 3.1 and 3.2

All inspection requirements have to be stated with the order. After supply of the equipment certificates can no longer be established. Charges and extent of the above mentioned certificates as well as the different tests confirmed therein are listed in our price list "Test and Inspection Charges for Standard Equipment".

For other tests and inspections than those listed above, please consult us.

### PED (Pressure Equipment Directive)

The equipment complies with the requirements of the Pressure Equipment Directive 97/23/CE. Applicable with fluids of group 1 and 2. With CE marking (apart from equipment that is excluded from the scope of the PED according to section 3.3). For more information refer to our PED Declaration of Conformity.

### ATEX (Atmosphère Explosible)

The equipment does not have its own potential source of ignition and is therefore excluded from the scope of the ATEX Directive 94/9/CE.

Applicable in Ex zones 0, 1, 2, 20, 21, 22 (1999/92/CE). The equipment does not bear an Ex marking. For more information refer to our ATEX Declaration of Manufacturer.

## GESTRA AG

P. O. Box 10 54 60, D-28054 Bremen  
Münchener Str. 77, D-28215 Bremen

Telephone +49 (0) 421 35 03 - 0, Fax +49 (0) 421 35 03-393

E-Mail gestra.ag@flowserve.com, Internet www.gestra.de



GESTRA