

GESTRA Steam Systems

Product Range A3

Programme-Controlled Blowdown System TA 5, TA 6

TA 5 TA 6

Description

Generation of periodic pulses to initiate a blowdown cycle via the GESTRA rapid-action intermittent blowdown valve type MPA, i.e. automation of intermittent boiler blowdown.

The equipment meets the German regulations for use in steam boiler plants operating without constant supervision or with limited supervision (TRD 602 and TRD 604).

Design

The programme-controlled blowdown system consists of an electric cycling timer, a three-way solenoid valve and a strainer for either compressed air or water.

The following designs are available:

TA 5

Cycling timer type PRS 7-b, ¼" three-way solenoid valve and ½" strainer supplied separately.

TA 6

As TA 5, however, all component parts assembled and interconnected on a mounting panel. The cycling timer type PRS-7b is protected by a sheet-steel case against dust and water jets.

Operation

The cycling timer type PRS-7b generates a control pulse which, after the preset blowdown interval, operates the three-way solenoid valve. This in turn actuates the rapid-action blowdown valve by means of compressed air or pressurized water and closes it again at the end of the pulse (blowdown) duration.

The blowdown intervals can be adjusted.

A push-button manual override is provided on the cycling timer type PRS-7b. A single push will initiate a blowdown cycle. The next automatic cycle is then carried out after the adjusted interval.

The push button allows a test of the blowdown system at any time as required by the regulations in force.

For test purposes and in the event of a mains failure the three-way solenoid valve can be operated by hand. The strainer is used to remove any dirt or rust particles from the compressed air or pressurized water.

Technical Data

Cycling Timer PRS-7b

Interval time T (blowdown interval)
Adjustable in steps of 0.5 h within a range of 0.5 h...31.5 h

Pulse duration t (blowdown duration)
Adjustable in steps of 1 s within a range of 1 s...63 s

Output

1 potential-free relay contact:
max. contact rating: 250 V, 500 W, 3 A ohmic with a life of 4×10^5 switching cycles or 0.35 A inductive with a life of 2×10^6 cycles; contact material silver, hard-gold plated

Indicators

1 LED flashing at one-second intervals
START/TEST push button as manual override, to initiate a single pulse and to set the timer to zero

Mains supply

220 V, 50...100 Hz, 3.5 VA (other voltages on request)

Protection

IP 40
IP 65 (PRS-7b in sheet-steel case)

Permissible ambient temperature

0...55 °C
0...70 °C (PRS-7b in sheet-steel case)

Sheet-steel case

grey hammertone finish,
2 cable glands Pg 11

Approx. weight

sheet-steel case included
1.4 kg

Three-Way Solenoid Valve

Connection

¼", BSP (DIN 259)

Max. service pressure

16 barg (230 psig)

Min. differential pressure required for opening and closing

0.5 bar (7.2 psi)

Duty cycle

100 %

Position of installation

as required, code letters for connections:

P = Pressure connection

A = Valve outlet

R = Exhaust or drain outlet

Mains supply

220 V, 50 Hz, 15 VA, inrush 30 VA
(other voltages and frequencies on request)

Protection

IP 65

Permissible ambient temperature

55 °C

Approx. weight

0.9 kg

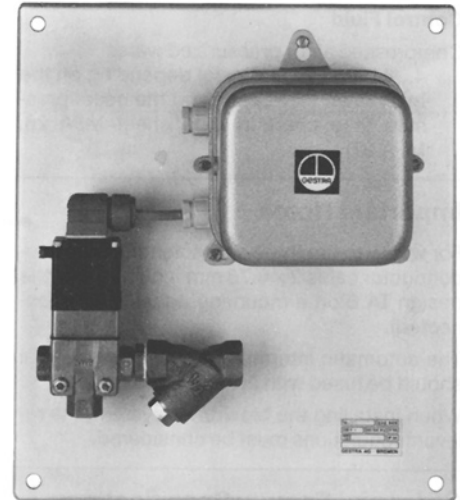

Programme-controlled blowdown system TA 6 on a mounting panel

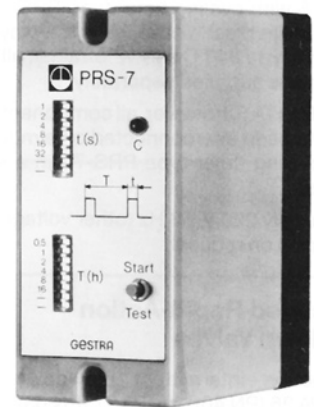

Cycling timer PRS-7b as plug-in unit in plastic case

Strainer

Connection

½" BSP (DIN 259)

Material

Body: gun metal Rg 5
Filter cartridge: ss 1.4571

Mesh size

0.5 mm

Approx. weight

0.3 kg

Control Fluid

Compressed air or pressurized water, 4...8 barg (58...116 psig) depending on the blowdown valve used and the boiler pressure (see chart in data sheet MPA 26, MPA 27).

Important Notes

For wiring to the three-way solenoid valve two-conductor cable 2 x 0.75 mm² can be used (the design TA 6 on a mounting panel is interconnected).

The automatic intermittent blowdown control should be fused with 2.5 A (inert fuse).

When installing the blowdown system, the relevant regulations must be considered.

Order and Enquiry Specifications

GESTRA programme-controlled blowdown system with the GESTRA rapid-action intermittent blowdown valve, control fluid compressed air or pressurized water:

Type TA 5 with cycling timer type PRS 7-b as plug-in unit in plastic case, ¼" three-way solenoid valve type 340 C and ½" strainer, all component parts supplied separately.

Type TA 6 as TA 5, however, all component parts assembled and interconnected on a mounting panel, cycling timer type PRS-7b in a sheet-steel case.

Mains supply 220 V, 50 Hz (other voltages and frequencies on request).

Associated Rapid-Action Blowdown Valves

Rapid-action intermittent blowdown valve type MPA 26 (PN 40) or MPA 27 (PN 63).

Installation and Service Instructions

Installation

Design TA 5: mount and interconnect component parts at the place of installation; the max. ambient temperature must not exceed 55 °C.

Connect outlet port of strainer to pressure connection of three-way solenoid valve using a reducer (strainer side screwed ½" BSP, solenoid valve side screwed ¼" BSP).

Connect control-fluid line (compressed air or pressurized water) to inlet port of strainer screwed ½" BSP.

Use a pipe 10 x 1 mm as control line leading to the rapid-action blowdown valve, connect to connection A of solenoid valve.

If pressurized water is used as control fluid, connect a drain line to connection R of the solenoid valve (screwed ¾" BSP) with an inside diameter of approx. 12 mm, so that the water is immediately discharged without banking-up and the blowdown valve closed rapidly.

Note

For the installation of the rapid-action blowdown valve see "Installation Instructions MPA 26, MPA 27".

Wiring

Wiring should be carried out in accordance with wiring diagram (see last page).

In the case of the PRS-7b remove cable entries in the base to introduce cable. After wiring replace cover and tighten screws.

Adjustment of Interval Time T (Blowdown Interval)

Example

Requested interval time T = 3.5 h

$$\frac{0.5}{1} \times \frac{1}{2} = 3.5 \text{ h}$$

Move the 0.5, 1 and 2 T (h) switches on the front panel to the left using a small screwdriver.

Adjustment of Pulse Duration t (Blowdown Duration)

The pulse duration is set at our works to 2 seconds for effective blowdown and to avoid blowdown wastage. Before extending the pulse (blowdown) duration t it is essential to check whether longer blowdown durations are allowable for the boiler (lowering of water level, overheating of water-tube boilers etc.).

Dimensions

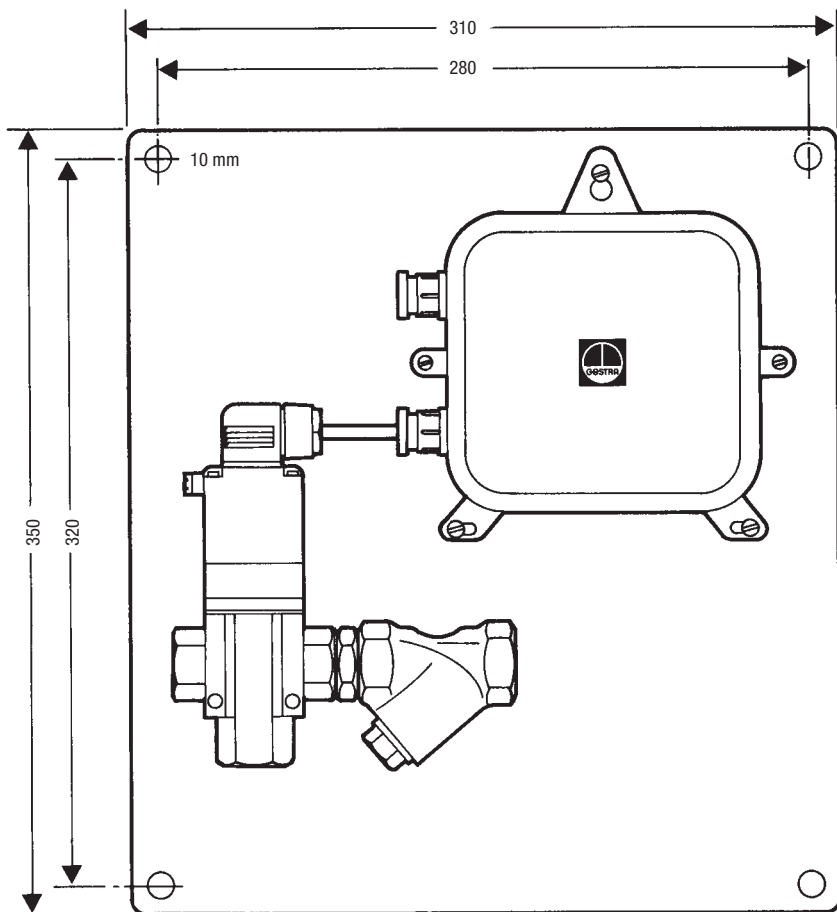

Programme-controlled blowdown system type TA 6 with cycling timer type PRS-7b in sheet-steel case, three-way solenoid valve and strainer on a mounting panel.

Commissioning

After switching on mains voltage, the system is ready for operation. This is indicated by flashing of the light-emitting diode on the PRS-7b. Push button START/TEST on the PRS-7b. This will initiate a single pulse. The next pulse is then released after the adjusted interval time T.

By pushing the button START/TEST on the PRS-7b a pulse can be initiated at any time during operation.

Performance Test

When pushing the button START/TEST on the PRS-7b, the rapid-action blowdown valve should open and close easily, otherwise clean filter or eliminate any other possible flow resistance.

For monitoring purposes or in the event of a power failure, the rapid-action blowdown valve can be actuated manually with the button provided on the three-way solenoid valve.

Dimensions

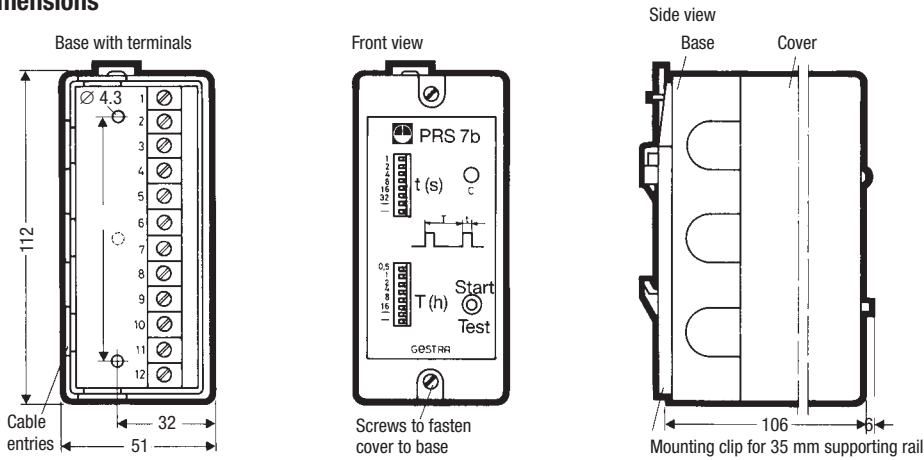

- ⊕ holes to be drilled to 4.3 mm dia for installation of unit in boiler panel
- ⊕ hole drilled for mounting clip

Cycling timer type PRS-7b as plug-in unit in plastic case, component part of programme-controlled blowdown system type TA 5

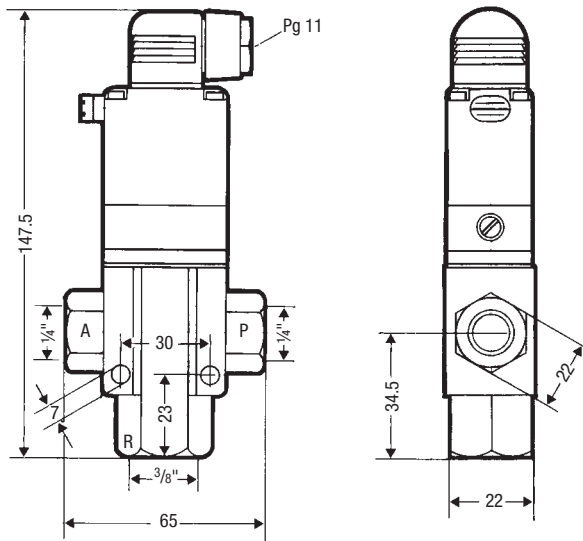

Three-way solenoid valve type 340 C, 1/4", component part of programme-controlled blowdown systems types TA 5, TA 4

Programme-Controlled
Blowdown System
TA 5, TA 6

Schematic Lay-out

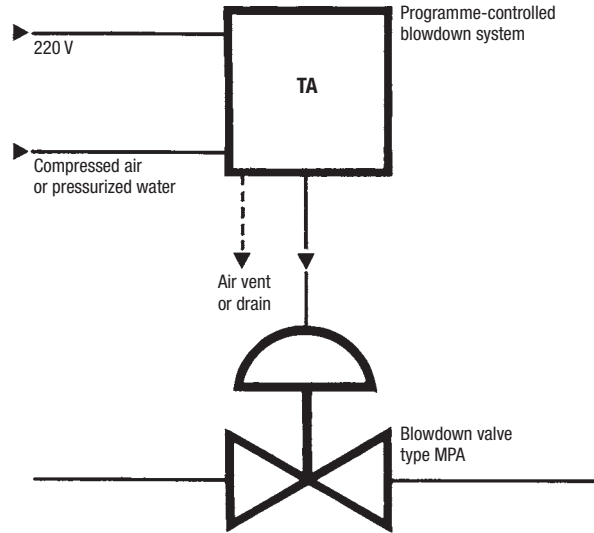

Wiring Diagram

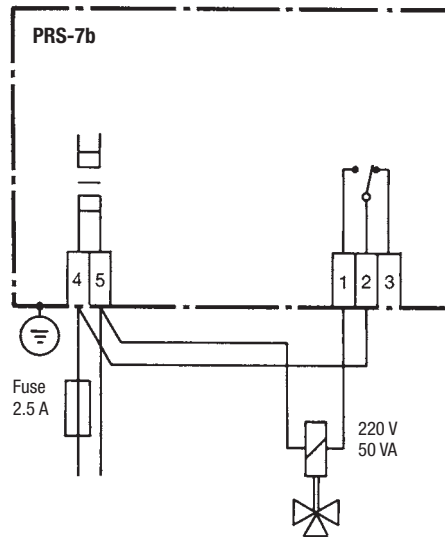

*Cycling timer type PRS-7b in sheet-steel case,
for programme-controlled blowdown systems types TA 5, TA 6*

Supply in accordance with our general terms
of business.

GESTRA AG

P. O. Box 10 54 60, D-28054 Bremen
Münchener Str. 77, D-28215 Bremen
Telephone +49 (0) 421 35 03 - 0, Fax +49 (0) 421 35 03-393
E-Mail gestra.ag@flowserve.com, Internet www.gestra.de



GESTRA