

## GESTRA Steam Systems

Product Range A1

Steam Traps

Kondensomat®

**MK 36-51, MK 36-52**

**Stainless Steel Design, DN 1/4", 3/8", 1/2", 3/4"**

**MK 36-51**

**MK 36-52**

### Description

Thermostatic steam trap with integral strainer and corrosion-resistant membrane regulator (thermostatic capsule) unaffected by waterhammer. The standard version "N" of the thermostatic capsule discharges the condensate with virtually no banking-up, the version "U" with approx. 30 K undercooling.

#### MK 36/51 with tandem seat (double seating)

In particular for low condensate flowrates.

Either with thermostatic capsule 5N1 (normal capsule) or thermostatic capsule 5U1 (undercooling capsule).

#### MK 36/52 with flat seat

For larger condensate flowrates.

Either with thermostatic capsule 5N2 (normal capsule) or thermostatic capsule 5U2 (undercooling capsule).

Installation in horizontal and vertical pipes.

### Pressure/Temperature Ratings

Regulator			
Max. service pressure PMA	[bar]	32	
Max. service temperature TMO	[°C]	250	
Max. service pressure PMA	[psi]	464	
Max. service temperature TMO	[°F]	482	
Admissible differential pressure ΔPMX (inlet pressure minus outlet pressure)	[bar] [psi]	32 464	
Body			
Max. design pressure PMA	[bar]	28	49
Max. design temperature TMA	[°C]	400	20
Max. design pressure PMA	[psi]	406	711
Max. design temperature TMA	[°F]	752	68

### Materials

		DIN / EN	ASME
Body		1.4301	A479 Type 304
Thermostatic regulator	Capsule	Hastelloy® Stainless steel	
Butt-weld nipples (optional)		P250 GH (1.4404, 1.4435)	
Union nuts		C35 (1.0501)	
Gasket		1.4301	
Other internals		Stainless steel	

### Weight

		Design	
		Screwed sockets	Union/ butt-weld nipples
Nominal sizes	[mm]	8 – 20	15
	[inch]	1/4 – 3/4	1/2
Weight approx. 0.8 kg	[kg]	0.4	0.68

### End Connections

Screwed sockets: BSP and NPT (1/4", 3/8", 1/2", 3/4")

Union butt-weld nipples (1/2")

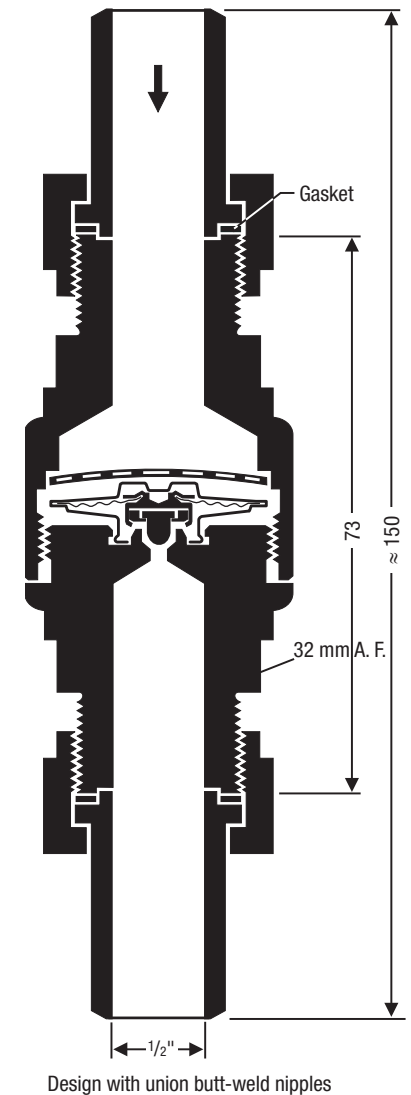
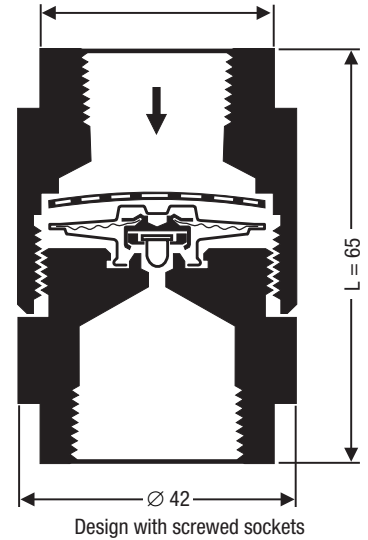

Steam Traps  
Kondensomat®  
**MK 36-51, MK 36-52**  
Stainless Steel Design,  
DN 1/4", 3/8", 1/2", 3/4"

**Capacity Chart**

The chart shows the maximum capacities for hot and cold condensate.

**Curve ① (MK 36-51)**

Indicates the max. capacity of hot condensate that the trap with 5N1 capsule can discharge at a condensate temperature of approx. 10 K below boiling temperature, and the trap with 5U1 capsule can discharge with an undercooling of approx. 30 K below boiling temperature (banking-up of condensate).

**Curve ② (MK 36-51)**

Discharge capacity for cold condensate at approx. 20 °C.

**Curve ③ (MK 36-52)**

Indicates the max. capacity of hot condensate that the trap with 5N2 capsule can discharge at a condensate temperature of approx. 10 K below boiling temperature, and the trap with 5U2 capsule can discharge with an undercooling of approx. 30 K below boiling temperature (banking-up of condensate).

**Curve ④ (MK 36-52)**

Discharge capacity for cold condensate at approx. 20 °C.

**Capacity Chart**

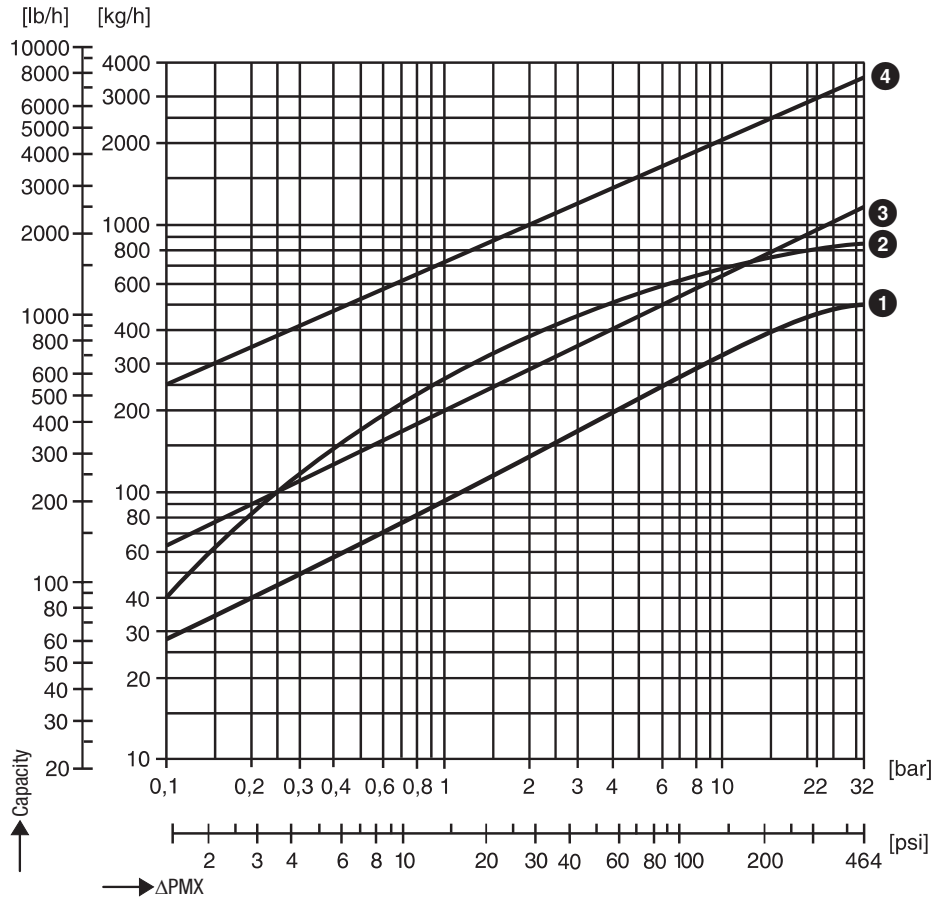

**When ordering please state:**

Material, steam pressure, steam temperature, back pressure, condensate flowrate, design, end connections, nominal size, details of application or type of steam consumer.

The following test certificates can be issued on request, at extra cost:

In accordance with EN 10204, -2.2 and 3.1.

All inspection requirements have to be stated with the order. After supply of the equipment certification cannot be established. Charges and extent of the above mentioned certificates as well as the different tests confirmed therein are listed in our price list "Test and Inspection Charges for Standard Equipment". For other tests and inspections than those listed above, please consult us.

**PED (Pressure Equipment Directive)**

The equipment fulfils the requirements of the Pressure Equipment Directive PED 97/23/EC.

For use with fluids of group 2.

The equipment is excluded from the scope of the PED according to Article 3.3 and must not bear a CE marking.

**ATEX (Atmosphère Explosible)**

The equipment does not have its own potential source of ignition and is therefore not subject to the ATEX-Directive 94/9/EC.

Applicable in Ex-zones 0, 1, 2, 20, 21 (1999/92/EC). The equipment does not bear an Ex marking.

Supply in accordance with our general terms of business.

**Spare Parts**

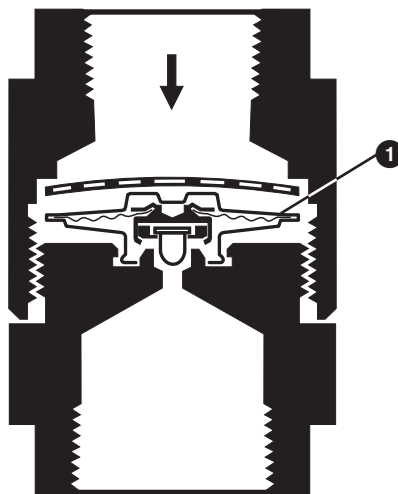

Item	Designation	Stock code #
①	Thermostatic capsule 5N1, 10 pcs.	376165
①	Thermostatic capsule 5U1, 10 pcs.	376166
①	Thermostatic capsule 5N2, 10 pcs.	376167
①	Thermostatic capsule 5U2, 10 pcs.	376168

**GESTRA AG**

P. O. Box 10 54 60, D-28054 Bremen  
Münchener Str. 77, D-28215 Bremen

Telephone +49 (0) 421 35 03 -0, Fax +49 (0) 421 35 03-393

E-mail gestra.gmbh@flowserve.com, Internet www.gestra.de



GESTRA