

# Steam Traps

## Float-controlled Steam Traps KA 2K

Condensate Trap for Compressed Air and Gases



### Technical Data

Connection G	1/2 x 1/2A 3/4 x 1/2A 1 x 3/4A
Nominal Pressure PN	16
Operating Pressure	0 - 12
Flow Rate	1570 l/h
Temperature	80 °C
Medium	compressed air, gases

### Description

The cold condensate trap KA 2K has especially been designed for draining compressed air and gases (e.g. biogas).

Steam traps automatically drain condensate without loss of steam or gas. They operate instantaneously and are not affected by backpressure or pressure fluctuations. They do not require an external energy input.

KA 2K are float-controlled condensate traps for universal use and especially suitable for particularly aggressive condensate. They are completely made of stainless steel featuring maximum corrosion resistance. The valve is equipped with a soft seal and, therefore, absolutely gastight.

Three working pressure ranges can be selected, please refer to the table on the right. The optimised valve mechanism consisting of float, lever and valve seat ensures a reliable and gastight operation also in the millibar working pressure range.

Top and bottom sections of the valve body are connected by a clamp ring and two bolts. Servicing/maintenance is easy and does not call for special tooling.

The simple design makes it easy to specify, install, handle and service these valves in an industrial environment.

### Standard

- » all stainless steel construction
- » quick-release body clamp ring
- » Connection sleeve for gas commuting line (compensation line)

### Options

- » various seal materials suitable for your medium
- » ATEX protection class  $\text{Ex II 2G c II A}$
- » special versions on request

Operating instructions, know how and safety instructions must be observed. All the pressure has always been indicated as overpressure. We reserve the right to alter technical specifications without notice.



### Pressure Ranges [bar]

0 - 2	0 - 6	0 - 12
-------	-------	--------

### Flow Rate [l/h]

$\Delta p$ bar	G 1/2 - G 3/4 x 1/2A			G 1 x 3/4A		
	pressure range bar			pressure range bar		
	0 - 2	0 - 6	0 - 12	0 - 2	0 - 6	0 - 12
0,02	30	11	2	150	34	11
0,05	50	17	4	240	54	17
0,1	70	19	6	350	75	25
0,2	100	28	9	490	105	35
0,5	160	40	12	780	170	55
1	230	70	18	1100	240	75
2	350	110	27	1570	340	110
4	-	160	46	-	480	155
6	-	200	50	-	590	190
8	-	-	60	-	-	220
10	-	-	70	-	-	250
12	-	-	75	-	-	270

# Steam Traps

## Float-controlled Steam Traps KA 2K

Condensate Trap for Compressed Air and Gases



Materials	
Body	CrNiMo-steel
Body Seal	FPM
Seat, Cone	CrNiMo-steel
Float	CrNiMo-steel
Valve Seal	FPM

Dimensions [mm]			
size	nominal diameter		
	G 1/2 x 1/2A	G 3/4 x 1/2A	G 1 x 3/4A
A	87	27	140
B	100	135	145
C	45	-	40
D	140	140	200
E	G 1/4	G 1/4	G 1/4

Weights[kg]			
nominal diameter			
G 1/2 x 1/2A	G 3/4 x 1/2A	G 1 x 3/4A	
1.1	0.85	2.6	

**Installation Example:**  
 The condensate is to pass unobstructed towards the condensate trap with a slope.  
 In case a surge chamber is formed (especially in horizontal lines with shut-off valves), a compensation line must be provided. The line will be connected to the corresponding sleeve at the upper casing and to the receiver or the pipeline located behind it.

Special designs on request.  
 The pressure has always been indicated as overpressure.  
 Mankenberg reserves the right to alter or improve the designs or specifications of the products described herein without notice.

### Dimensional Drawing

#### G 1/2 x 1/2A

compensation line connection G 1/4

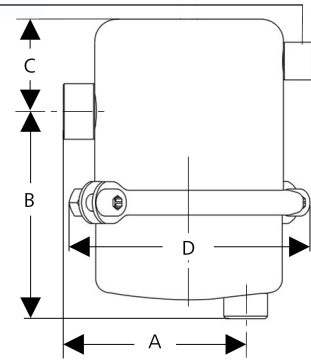

#### G 3/4 x 1/2A

compensation line connection G 1/4

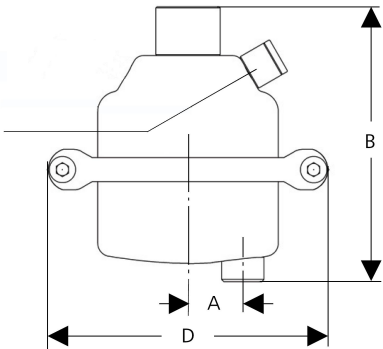

#### G 1 x 3/4A

compensation line connection G 1/4

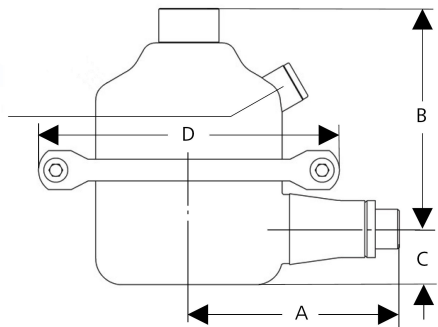

### Recommended Installation

right

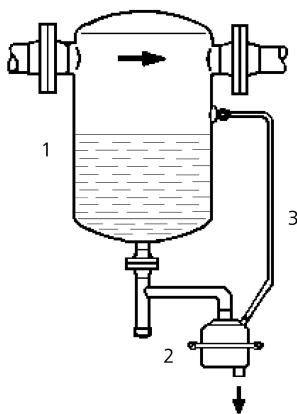

1 condensate collection tank

right

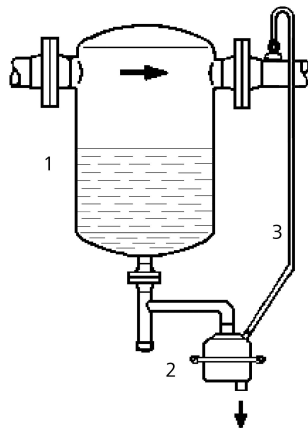

2 condensate trap

wrong

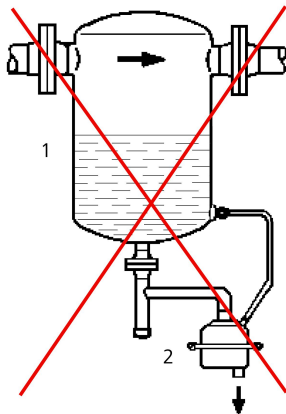

use MANKENBERG-products

wrong

