



**FLOWSERVE**

GESTRA

## GESTRA Steam Systems

# AK 45



## Installation Instructions 810467-03

Condensate Drain Valve  
AK 45



# Contents

Page

## Important Notes

Usage for the intended purpose .....	4
Safety note .....	4
Danger .....	4
Attention .....	4
PED (Pressure Equipment Directive) .....	5
ATEX (Atmosphère Explosible) .....	5

## Explanatory Notes

Scope of supply .....	6
Description .....	6
Function .....	6

## Technical Data

Corrosion resistance .....	7
Sizing .....	7
Name plate / Marking .....	7

## Design

AK 45 .....	8
Key .....	9

## Installation

AK 45 .....	10
Flanged design .....	10
Screwed-socket design .....	10
Socket-weld design .....	11
Butt-weld design .....	11
Heat treatment of welds .....	11
Draining of a steam main .....	12
Draining of a pipe bend .....	12

## Commissioning

AK 45 .....	12
-------------	----

# Contents - continued -

Page

## Operation

AK 45 .....	13
-------------	----

## Maintenance

Cleaning condensate drain valve.....	13
Tools .....	13
Replacing hand purging knob and valve insert .....	14
Tools.....	14
Torques required for tightening .....	14

## Spare Parts

Spare parts list .....	15
------------------------	----

## Decommissioning

Danger .....	15
Disposal.....	15

## Important Notes

### Usage for the intended purpose

Use condensate drain valve AK 45 only for the discharge of condensed water.  
Application in steam lines for the discharge of condensate only within the specified pressure and temperature ratings. Check corrosion resistance and chemical suitability for the application in question.

### Safety note

The equipment must only be installed and commissioned by qualified and competent staff.  
Maintenance and service work must only be performed by adequately trained persons who have a recognized level of competence.



#### Danger

The equipment is under pressure during operation.  
When loosening flanged connections or sealing plugs, hot water and steam may escape.  
This presents the risk of severe scalding all over the body!  
Before carrying out installation and maintenance work make sure the system is depressurized. Isolate the equipment from both upstream and downstream pressure.  
The equipment becomes hot during operation.  
This presents the risk of severe burns to hands and arms.  
Before carrying out installation and maintenance work make sure that the equipment is cold.  
Before carrying out any maintenance work on the equipment or loosening flanged connections or sealing plugs make sure that all connected lines are depressurized (0 bar) and cooled down to room temperature (20 °C).  
Sharp edges on internals present a danger of cuts to hands.  
Always wear industrial gloves when replacing the regulator or the strainer.



#### Attention

The name plate specifies the technical features of the equipment. Note that any item of equipment without its specific name plate must neither be commissioned nor operated.

## **Important Notes** - continued -

### **PED (Pressure Equipment Directive)**

The equipment fulfills the requirements of the Pressure Equipment Directive PED 97/23/EC. AK 45 can be used with fluids of group 2. The equipment is excluded from the scope of the PED according to section 3.3 and is therefore not CE marked.

### **ATEX (Atmosphère Explosible)**

The equipment does not have its own potential source of ignition and is therefore not subject to the ATEX Directive 94/9/EG. Applicable in Ex zones 0, 1, 2, 20, 21, 22 (1999/92EC).  
The equipment does not bear an Ex marking.

## Explanatory Notes

### Scope of supply

#### AK 45

- 1 Condensate Drain Valve AK 45
- 1 Installation manual

### Description

The AK 45 automatically discharges condensate from steam systems during start-up. The AK 45 closes automatically as soon as the pressure in the system has reached the adjusted valve closing pressure. At shut-down or when the pressure falls below the closing pressure the valve opens and accumulated condensate is automatically discharged.

### Function

When there is no pressure in the system the drain valve AK 45 is held in the open position by the integrated spring. As soon as the service pressure has reached the adjusted closing pressure, the AK 45 closes (due to the differential pressure acting on the valve cone against the force of the spring). When the pressure drops below the closing pressure, the spring forces the AK 45 to open.

The hand purging knob allows the brief opening of the valve during operation in order to remove any dirt deposits on the valve seat.

The AK 45 is adjusted at our works to close at a differential pressure of 0.8 barg (12 psig) (other closing pressures available on request).

Other closing pressures are indicated on the name plate.

The AK 45 is equipped with an internal strainer.

## Technical Data

### Corrosion resistance

If the equipment is used for the intended purpose, its safety is not impaired by corrosion.

### Sizing

The housing must not be subjected to sharp increases in pressure. The dimensional allowances for corrosion reflect the latest state of technology.

### Name plate / Marking

The temperature/pressure ratings are indicated on the valve body or on the name plate. For more information see GESTRA technical documents such as data sheets and the Technical Information. According to EN 19 the valve type and design are indicated on the name plate and the valve body:

- Name/logo of the manufacturer
- Type designation: AK 45
- Pressure rating PN
- Marking according to ATEX: The equipment does not bear an Ex marking.
- Material number
- Max. temperature
- Max. pressure
- Direction of flow
- Stamp on valve body, e. g.  $\frac{1}{05}$  indicates term and year of production (Example: 1<sup>st</sup> quarter 2005)

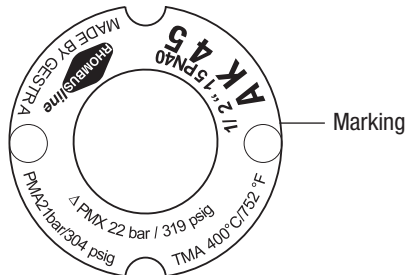

Fig. 1

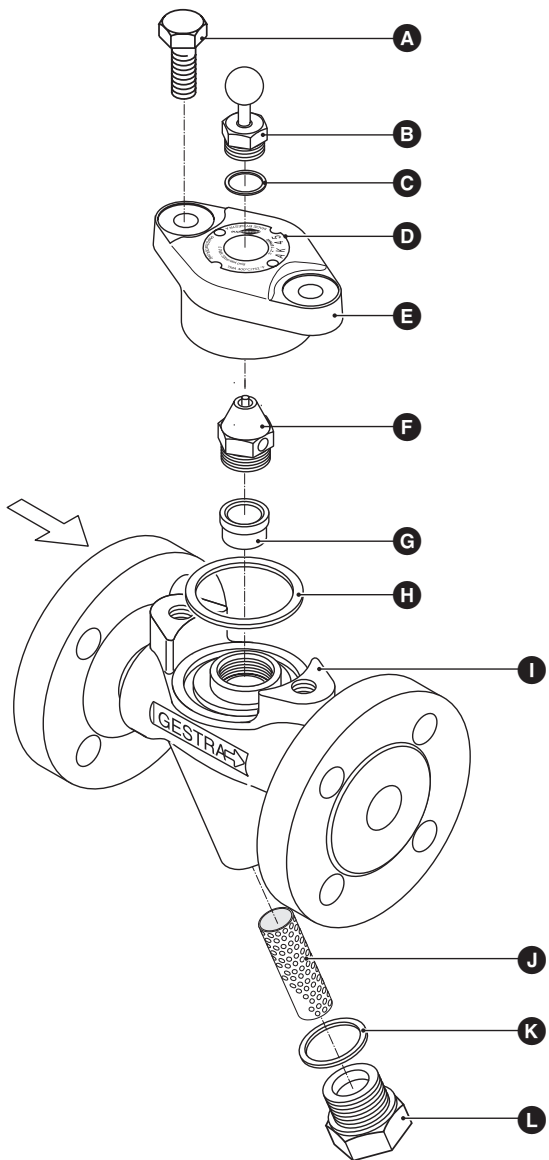

Fig. 2



### Key

- A** Hexagon head screw M 10 x 25, to EN 24017, made from 1.7258
- B** Hand purging knob
- C** Gasket A 14 x 18
- D** Name plate
- E** Cover
- F** Valve insert
- G** Bushing (interference fitted, no spare part)
- H** Body gasket 40 x 48 x 2
- I** Body
- J** Strainer
- K** Gasket A 24 x 29
- L** Sealing plug

## Installation

### AK 45

The equipment can be installed in any plane with flow in the direction of the arrow. When the equipment is installed in a horizontal pipe, the cover should be on top.

The AK 45 must be installed in such a way that free drainage is allowed (no back pressure), i. e. discharge to atmospheric pressure, and the pipework should be arranged so that the system can drain down by gravity when shut down. If possible the equipment should be installed in a vertical pipe.

If the AK 45 has to be installed in a horizontal line, the pipe on the discharge side of the equipment should feature a 90° downward bend. **Fig. 3, Fig. 4**

### Flanged design

1. Observe position of installation.
2. Observe direction of flow. The arrow indicating the flow direction is on the trap body.
3. Consider space required for opening or servicing the valve. Leave at least **40 mm** free space around the condensate drain valve for the subsequent removal of the cover **E**.
4. Remove plastic plugs. They are **only** used for transit protection.
5. Clean seating surfaces of both flange faces.
6. Install condensate drain valve

### Screwed-socket design

1. Observe position of installation.
2. Observe direction of flow. The arrow indicating the flow direction is on the trap body.
3. Consider space required for opening or servicing the valve. Leave at least **40 mm** free space around the condensate drain valve for the subsequent removal of the cover **E**.
4. Remove plastic plugs. They are **only** used for transit protection.
5. Clean female threads.
6. Install condensate drain valve

### Socket-weld design

1. Observe position of installation.
2. Observe direction of flow. The arrow indicating the flow direction is on the trap body.
3. Consider space required for opening or servicing the valve. Leave at least **40 mm** free space around the condensate drain valve for the subsequent removal of the cover **E**.
4. Remove plastic plugs. They are **only** used for transit protection.
5. Remove valve insert as described in the section **Maintenance**.
6. Clean socket-weld ends.
7. Apply **only** electric arc welding process (welding process 111 and 141 in accordance with ISO 4063).

### Butt-weld design

1. Observe position of installation.
2. Observe direction of flow. The arrow indicating the flow direction is on the trap body.
3. Consider space required for opening or servicing the valve. Leave at least **40 mm** free space around the condensate drain valve for the subsequent removal of the cover **E**.
4. Remove plastic plugs. They are **only** used for transit protection.
5. Clean butt-weld ends.
6. Apply electric arc welding process (welding processes 111 and 141 in accordance with ISO 4063) or use gas welding process (welding process 3 in accordance with ISO 4063).



#### Attention

- Only qualified welders certified e. g. according to EN 287-71 may weld the condensate drain valve into pressurized lines.
- The condensate drain valve must **not** be insulated.

### Heat treatment of welds

A subsequent heat treatment of the welds is not required.

## Installation - continued -

### Draining of a steam main

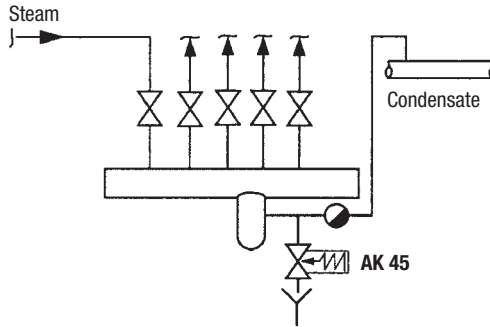

Fig. 3 Draining a steam main with an elevated condensate line

### Draining of a pipe bend

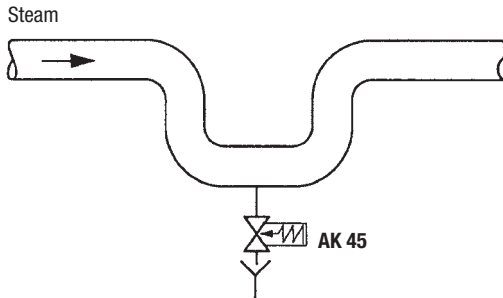

Fig. 4 Draining of a pipe bend

## Commissioning

### AK 45

Make sure that the flanged connections of the AK 45 are tightly bolted together and leakproof.

## Operation

### AK 45

The default factory setting of the valve ensures that the AK 45 closes when the steam pressure reaches e.g. 0.8 bar. For other closing pressures please contact GESTRA AG.

## Maintenance

The GESTRA condensate drain valve AK 45 requires no special maintenance. However, if used in new installations which have not been rinsed it may be necessary to inspect and clean the trap.

### Cleaning condensate drain valve

1. Observe the danger note on page 4!
2. Unscrew body screws **A** and take the cover **E** off the body **I**. **Fig. 2**
3. Remove and clean valve insert **F**.
4. Unscrew sealing plug **L** and strainer **J**.
5. Clean body and internals. Clean gasket surfaces.
6. Clean seating surfaces of body and cover.
7. Apply heat-resistant lubricant (e. g. WINIX® 2150) to all threads, seating surfaces of the valve insert and of the cover .
8. Screw in valve insert **F** and tighten with the torque indicated in the table "Torques required for tightening".  
Replace gasket **H** only if there are visible signs of damage.
9. Replace gasket **K** if there are visible signs of damage.
10. Put cover onto valve body. Tighten body screws with the torques indicated in the table "Torques required for tightening".
11. Mount sealing plug **L** together with strainer **J** and tighten with the torques indicated in the table "Torques required for tightening".

### Tools

- Combination spanner A. F. 16 mm, DIN 3113, Form B
- Combination spanner A. F. 22 mm, DIN 3113, Form B
- Torque spanner 20-120 Nm, DIN ISO 6789

## Replacing hand purging knob and valve insert

1. Observe the danger note on page 4!
2. Unscrew body screws **A** and take the cover **E** off the body **I**. Fig. 2
3. Unscrew hand purging knob **B**.
4. Unscrew valve insert **F**.
5. Unscrew sealing plug **L** and strainer **J**.
6. Clean strainer, sealing plug and gasket surfaces.
7. Clean seating surfaces of body and cover.
8. Apply heat-resistant lubricant (e. g. WINIX® 2150) to all threads, seating surfaces of the valve insert and of the cover.
9. Replace gasket **H** only if there are visible signs of damage.
10. Replace gasket **K** if there are visible signs of damage.
11. Mount new hand purging knob **B** and tighten with the torque indicated in the table "Torques required for tightening".
12. Mount new valve insert **F** and tighten with the torque indicated in the table "Torques required for tightening".
13. Put cover onto valve body. Tighten body screws with the torques indicated in the table "Torques required for tightening".
14. Mount sealing plug **L** together with strainer **J** and tighten with the torques indicated in the table "Torques required for tightening".

## Tools

- Combination spanner A. F. 16 mm, DIN 3113, Form B
- Combination spanner A. F. 19 mm, DIN 3113, Form B
- Combination spanner A. F. 22 mm, DIN 3113, Form B
- Torque spanner 20-120 Nm, DIN ISO 6789

## Torques required for tightening

Item	Designation	Torque [Nm]
<b>F</b>	Valve insert	90
<b>B</b>	Hand purging knob	40
<b>A</b>	Body screws	25
<b>L</b>	Sealing plug	120

All torques indicated in the table are based at a room temperature of 20 °C.

## Spare Parts

### Spare parts list

Item	Designation	Stock code
<b>B C</b>	Hand purging knob with gasket	375435
<b>F H</b>	Valve insert with body gasket	375434
<b>J K L</b>	Strainer, cpl.	375113
<b>H</b>	Gasket*) 40 x 48 x 2, graphite	375159

\*) Minimum purchasing quantity 50 items. For smaller quantities please contact your local dealer.

## Decommissioning



### Danger

Risk of severe burns and scalds to the whole body!

Before loosening flanged connections or sealing plugs make sure that all connected lines are depressurized (zero bar) and cooled down to room temperature (20 °C).

## Disposal

Dismantle the equipment and separate the waste materials, using the material specification as a reference.

For the disposal of the equipment observe the pertinent legal regulations concerning waste disposal.



GESTRA

Agencies all over the world:

**www.gestra.de**

### España

#### **GESTRA ESPAÑOLA S.A.**

Luis Cabrera, 86-88  
E-28002 Madrid  
Tel. 00 34 91 / 5 15 20 32  
Fax 00 34 91 / 4 13 67 47; 5 15 20 36  
E-mail: aromero@flowserve.com

### Polska

#### **GESTRA POLONIA Spolka z.o.o.**

Ul. Schuberta 104  
PL - 80-172 Gdansk  
Tel. 00 48 58 / 3 06 10 - 02  
00 48 58 / 3 06 10 - 10  
Fax 00 48 58 / 3 06 33 00  
E-mail: gestra@gestra.pl

### Great Britain

#### **Flowserve GB Limited**

Abex Road  
Newbury, Berkshire RG14 5EY  
Tel. 00 44 16 35 / 46 99 90  
Fax 00 44 16 35 / 3 60 34  
E-mail: gestraukinfo@flowserve.com

### Portugal

#### **Flowserve Portuguesa, Lda.**

Av. Dr. Antunes Guimarães, 1159  
Porto 4100-082  
Tel. 0 03 51 22 / 6 19 87 70  
Fax 0 03 51 22 / 6 10 75 75  
E-mail: jtavares@flowserve.com

### Italia

#### **Flowserve S.p.A.**

Flow Control Division  
Via Prealpi, 30  
I-20032 Cormano (MI)  
Tel. 00 39 02 / 66 32 51  
Fax 00 39 02 / 66 32 55 60  
E-mail: infoitaly@flowserve.com

### USA

#### **Flowserve GESTRA U.S.**

2341 Ampere Drive  
Louisville, KY 40299  
Tel.: 00 15 02 / 267 2205  
Fax: 00 15 02 / 266 5397  
E-mail: dgoodwin@flowserve.com

## GESTRA AG

P. O. Box 10 54 60, D-28054 Bremen  
Münchener Str. 77, D-28215 Bremen  
Telephone +49 (0) 421 35 03 - 0  
Fax +49 (0) 421 35 03 - 393  
E-Mail gestra.ag@flowserve.com  
Internet www.gestra.de

