

NRR 2-52, NRR 2-53

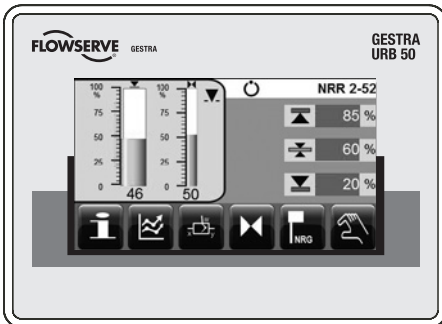

URB 50

## Level Controller

### NRR 2-52, NRR 2-53

### Operating & Display Unit

### URB 50

#### Description

The functional unit consisting of the operating & display unit URB 50 and the level controller NRR 2-52 / NRR 2-53 in conjunction with level electrodes NRG 2-.. and level transmitter NRG 26-1 is used as limit switch and water level controller, for instance in steam boilers, (pressurized) hot-water installations as well as condensate and feedwater tanks.

The functional unit consisting of the URB 50 and the level controller NRR 2-5.. can be used with level electrodes NRG 21-.. and NRG 26-21 as well as the level transmitter NRG 26-1.

#### Function

The operating & display unit URB 50 and the level controller NRR 2-52, NRR 2-53 form a functional unit featuring the following properties:

Level Controller	NRR 2-52	NRR 2-53
Evaluation of the voltage signal of the level electrode NRG 2-.. and standardized measuring range	X	X
Evaluation of current signal of level transmitter NRG 26-1	X	X
3-position stepping controller with proportional-plus-integral control action (PI controller) and control of an electrically actuated control valve	X	
Continuous controller as PI controller and control of an electro-pneumatically operated control valve		X
Indication of MIN / MAX water level limit	X	X
Current inputs for steam and feedwater flowrate (3-element control) (optional)	X	X
Indication of valve position via potentiometer incorporated in control valve	X	
Actual value output 4-20 mA (optional)	X	X
<b>Operating &amp; display unit</b>		<b>URB 50</b>
Indication of actual value (indicated in percent and as bar graph)		X
Indication of valve position (indicated in percent and as bar graph)		X
Standardized measuring range if level electrode NRG 2-.. is connected		X
Indication/adjustment of control parameters		X
Standardization and evaluation of current inputs for steam and feedwater flowrate (3-element control) (optional)		X
Trend record		X
Indication and listing of errors, alarms and warnings		X
Test of MIN / MAX output relays		X
Manual/automatic operation		X
Password protection		X

#### Directives and standards

##### VdTÜV Bulletin "Wasserstand 100" (= Water Level 100)

The functional unit consisting of the operating & display unit URB 50 / level controller NRR 2-52, NRR 2-53 in conjunction with level electrode NRG 2-.. and level transmitter NRG 26-.. is type approved according to VdTÜV Bulletin "Wasserüberwachung (= Water Monitoring) 100".

Type approval no. TÜV · WR · 12-427  
(see name plate).

The VdTÜV Bulletin "Wasserstand (=Water Level) 100" specifies the requirements made on water level control and limiting equipment for boilers.

##### LV (Low Voltage) Directive and EMC (Electromagnetic Compatibility)

The equipment meets the requirements of the Low Voltage Directive 2006/95/EC and the EMC Directive 2004/108/EC.

##### ATEX (Atmosphère Explosible)

According to the European Directive 94/9/EC the equipment must not be used in potentially explosive areas.

##### UL/cUL (CSA) Approval

The equipment meets the requirements of: UL 508 and CSA C22.2 No. 14-13, Standards for Industrial Control Equipment. File E243189, E199715.

# Level Controller

## NRR 2-52, NRR 2-53

### Technical data

#### Supply voltage

24 VDC, + / -20 %

#### Fuse

external 0.5 A (semi-delay)

#### Power consumption

5 VA

#### Connecting level electrode, level transmitter

(switch-selectable)

1 input for level electrode NRG 21-.. and NRG 26-21, with 3 poles and screen or

1 analogue input 4-20 mA, e. g. for level transmitter NRG 26-1, with 2 poles and screen.

#### Supply voltage for level electrode

12 VDC

#### Input/output

Interface for data exchange with operating & display unit URB 50

#### Inputs

1 analogue input, potentiometer 0 - 1000 Ω,  
Two-wire connection (indication of valve position, only NRR 2-52)

1 analogue input, 4-20 mA (steam flowrate) (optional)

1 analogue input, 4-20 mA (feedwater flowrate) (optional)

#### Outputs

**NRR 2-52:** 2 volt-free change-over contacts,  
8 A 250 V AC / 30 V DC cos φ = 1 (control valve).

2 volt-free change-over contacts,  
8 A 250 V AC / 30 V DC cos φ = 1,  
De-energizing delay: 3 seconds (MIN/MAX alarm).

**NRR 2-53:** 4 volt-free change-over contacts,

8 A 250 V AC / 30 V DC cos φ = 1

De-energizing delay: 3 sec. (MIN/MAX alarm)

1 analogue output 4-20 mA, max. load 500 ohm  
(manipulated variable Y)

Provide inductive loads with RC combinations according to manufacturer's specification to ensure interference suppression.

#### NRR 2-52, NRR 2-53:

1 analog output 4-20 mA,

max. load 500 ohm (actual value) (optional)

#### Indicators and adjusters

1 tri-colour LED indicator (start-up = amber, power ON = green, malfunction = red)

1 code switch with four poles for configuration

#### Housing

Housing material: base: polycarbonate, black

Front: polycarbonate, grey.

Terminal strips separately detachable.

Fixing of housing: Mounting clip on supporting rail TH 35, EN 60715

#### Electrical safety

Pollution degree 2.

#### Protection

Housing: IP 40 to EN 60529

Terminal strip: IP 20 to EN 60529

#### Weight

approx. 0.5 kg

#### Further conditions:

##### Ambient temperature

when system is switched on: 0 ... 55 °C,  
during operation: -10 ... 55 °C

##### Transport temperature

-20 ... +80 °C (< 100 hours), defrosting time of the de-energized equipment before it can be put into operation: 24 hours.

##### Storage temperature

-20 ... +70 °C, defrosting time of the de-energized equipment before it can be put into operation: 24 hours.

##### Relative humidity

max. 95%, no moisture condensation

## Dimensions

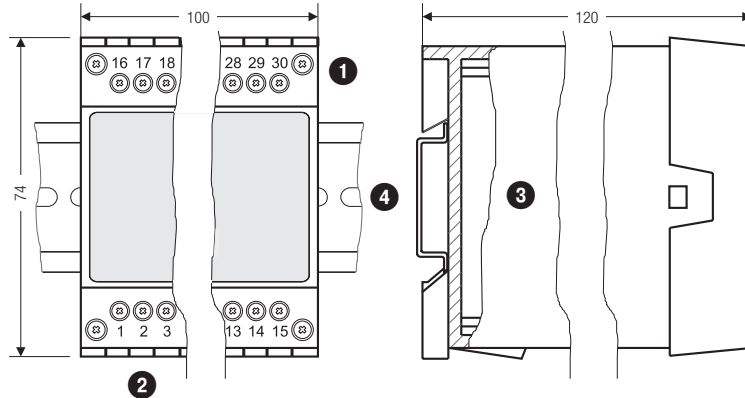

Fig. 1 NRR 2-52, NRR 2-53

## Electrical connection NRR 2-52

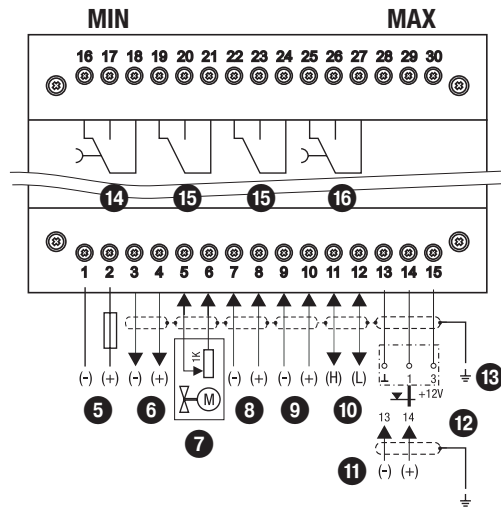

Fig. 2

## Electrical connection NRR 2-53

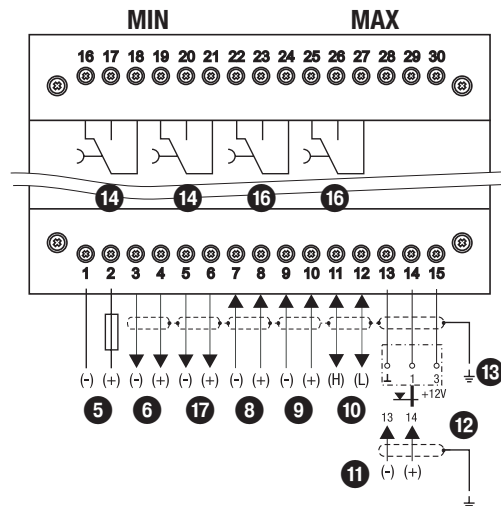

Fig. 3

## Key

- 1 Upper terminal strip
- 2 Lower terminal strip
- 3 Housing
- 4 Supporting rail type TH 35, EN 60715
- 5 Connection of supply voltage **24 V DC** with fuse 0.5 A (semi-delay), provided on site
- 6 Actual value output 4-20 mA (optional)
- 7 Indication of valve position, potentiometer 0 - 1000 Ω
- 8 IN 2 / 4-20 mA for feedwater flowrate (optional)
- 9 IN 3 / 4-20 mA for steam flowrate (optional)
- 10 Data line for operating & display unit URB 50
- 11 Level transmitter NRG 26-1, 4-20 mA, with earthing point
- 12 Level electrode NRG 21-..; NRG 26-21
- 13 Central earthing point (CEP) in control cabinet
- 14 MIN output contact(s), de-energizing delay: 3 sec.
- 15 Output contact for activating the control valve
- 16 MAX output contact(s), de-energizing delay: 3 sec.
- 17 Output 4-20 mA, manipulated variable Y

# Operating & Display Unit URB 50

## Technical data

### Supply voltage

24 VDC +/- 20%

### Fuse

internal automatic

### Power consumption

8 VA

### Input / output

Interface for data exchange with level controller NRR 2-52, NRR 2-53.

### User interface

Analogue resistive touch screen, resolution 480 x 271 pixels, illuminated

### Dimensions

Front panel 147 x 107 mm

Panel cut-out 136 x 96 mm

Depth 56 + 4 mm

### Electrical connection

1 three-pole connector

1 nine-pole D-SUB connector

### Protection

Front: IP 65 to EN 60529

Back: IP 20 to EN 60529

### Weight

approx. 1.0 kg

### Ambient temperature

when system is switched on: 0 ... 55 °C,  
during operation: -10 ... 55 °C

### Transport temperature

-20 ... +80 °C (<100 hours), defrosting time of the de-energized equipment before it can be put into operation: 24 hours.

### Storage temperature

-20 ... +70 °C, defrosting time of the de-energized equipment before it can be put into operation: 24 hours.

### Relative humidity

5-85 %, no moisture condensation

## Key

- 18** Cut-out in control cabinet 136 x 96 mm
- 19** Seal
- 20** D-SUB connector with 9 poles for data line
- 21** Connector with 3 poles for supply voltage connection **24 V DC**
- 22** Connection for supply voltage **24 V DC**, pin assignment
- CEP** Central earthing point (CEP) in control cabinet

## Dimensions

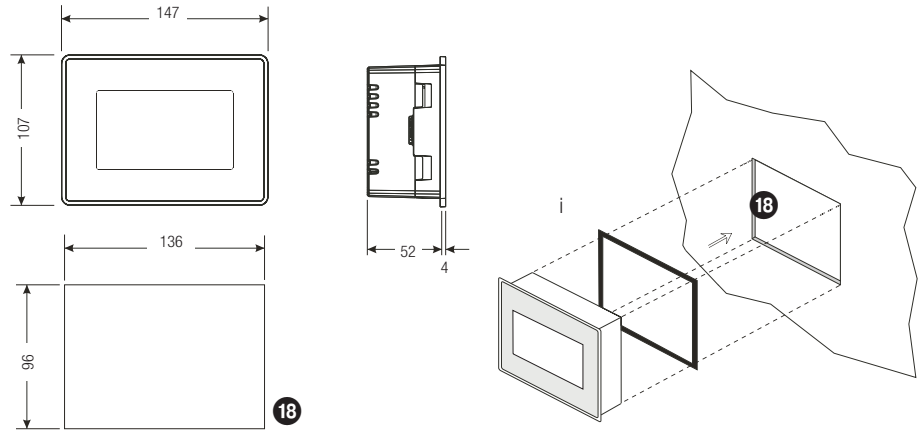
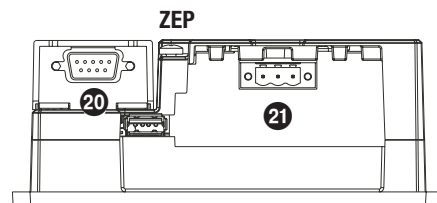

Fig. 4

## Electrical connection URB 50

### Back of equipment, position of connector



### Connection of supply voltage

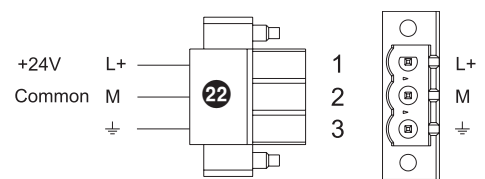

### Pin assignment for data line NRR 2-52, NRR 2-53 - URB 50

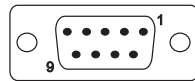

PIN 2	Data_L
PIN 7	Data_H

Fig. 5

## Order & Enquiry Specification

### Level controller type NRR 2-52

GESTRA SPECTOR<sup>module</sup> Touch

3-position stepping PI controller with MIN and MAX alarm.

Output: 2 volt-free change-over contacts for MIN/MAX alarm

1 volt-free relay contact for valve open / stop / closed incl.

1 separate operating & display unit type URB 50 with colour touch panel

Supply voltage: 24 V DC, 13 VA

Optional extras (please state when ordering):

1 actual value output 4-20 mA

3-element control

### Level controller type NRR 2-53

GESTRA SPECTOR<sup>module</sup> Touch

Continuous PI level controller with MIN and MAX alarm

Output: 1 current output 4-20mA for valve actuation

4 volt-free change-over contacts for MIN/MAX alarm

1 actual-value output 4-20 mA (optional) incl.

1 separate operating & display unit type URB 50 with colour touch panel

Supply voltage: 24 V DC, 13 VA

Optional extras (please state when ordering):

Actual value output 4-20 mA

3-element control

## Important Notes

The level controller NRR 2-52, NRR 2-53 is clipped onto the support rail in the control cabinet. The operating & display unit URB 50 is installed in the cut-out of the control cabinet.

The equipment is supplied with 24 V DC and fused with an external semi-delay fuse 0.5 A.

The power supply unit must be electrically isolated from dangerous contact voltages and must meet at least the requirements on double or reinforced isolation according to one of the following standards: DIN EN 50178, DIN EN 61010-1, DIN EN 60730-1 or DIN EN 60950.

To prevent the welding together of contacts provide an external slow-blow fuse T 2.5 A or 1.0 A (TRD 604, 72 hrs. operation) for the output contacts.

When switching off inductive loads, voltage spikes are produced that may impair the operation of control systems. Connected inductive loads must be provided with suppressors such as RC combinations as specified by the manufacturer.

To connect the level electrode / the level transmitter use screened multi-core control cable with a min. conductor size 0.5 mm<sup>2</sup>, e. g. LiYCY 4 x 0.5 mm<sup>2</sup>, max. length: 100 m.

Make sure that connecting cables between the equipment are segregated and run separately from power cables.

Supply in accordance with our general terms of business.

# GESTRA AG

P. O. Box 10 54 60, D-28054 Bremen, Germany

Münchener Str. 77, D-28215 Bremen, Germany

Tel. 0049 (0) 421 / 35 03-0, Fax 0049 (0) 421 / 35 03-393

E-mail [gestra.ag@flowserve.com](mailto:gestra.ag@flowserve.com), Internet [www.gestra.de](http://www.gestra.de)



GESTRA