

NRG 1...-51 with four-pole connector

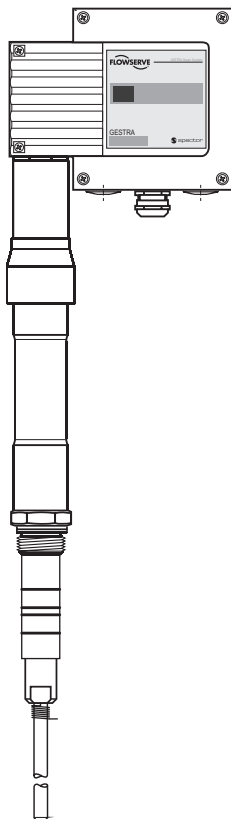

NRG 111-51F with aluminium terminal box

High-Level Alarm

Level Electrode

NRG 16-51, NRG 17-51, NRG 19-51, NRG 111-51

Description

The level electrodes NRG 1...-51 are used in conjunction with level switch NRS 1-51 as high level alarm for steam boiler plants and (pressurized) hot water installations.

A high level alarm prevents the water level from exceeding the preset max. water level (HW) and for this purpose switches off e. g. the feedwater supply.

Function

When the level exceeds the max. water level, the level electrode enters the liquid and an alarm is triggered in the level switch NRS 1-51. The switchpoint "High level (HW) exceeded" is dictated by the length of the electrode rod.

The electrode operation is based on the conductive measuring principle using the electrical conductivity of the water for signalling water level. The self-monitoring function ensures that an alarm will also be triggered if the electrode insulation is contaminated or has developed a leak or if there is a malfunction in the electrical connection.

The level electrode is installed inside steam boilers, vessels or inlet lines of hot-water systems. The protection tube provided on site ensures the correct functioning.

One level electrode NRG 1...-51 can be installed together with one GESTRA water level limiting electrode in a single protection tube or external level pot.

If the level electrode is installed in a level pot outside the boiler, make sure that the connecting lines are rinsed regularly. In addition, the logic unit SRL is required to monitor the purging times and the purging sequence.

If the connecting lines for steam ≥ 40 mm and water ≥ 100 mm, the installation is considered to be internal. In this case the rinsing processes do not have to be monitored.

Directives and standards

EC Pressure Equipment Directive 97/23/EC

The level electrode NRG 1...-51 in conjunction with level switch NRS 1-51 is EC type approved according to EN 12952/EN 12953. These Directives state, among other things, the requirements made on limiting systems and equipment for steam boiler plants and (pressurized) hot-water installations.

Functional Safety acc. to IEC 61508

The level electrode NRG 1...-51 is certified acc. to IEC 61508 only if used in combination with level switch NRS 1-51. This standard describes the functional safety of safety-related electrical/electronic/programmable electronic systems.

VdTÜV Bulletin "Wasserstand 100" (= Water Level 100)

The level electrodes NRG 1...-51, NRG 1...-12 in conjunction with the level switch NRS 1-51 are type approved according to the VdTÜV Bulletin "Water Level 100".

UL/cUL (CSA) Approval

The equipment complies with the requirements of the following standards: UL 508 and CSA C22.2 No. 14-13, Standards for Industrial Control Equipment. File E243189.

ATEX (Atmosphère Explosible)

The level electrodes NRG 1...-51, NRG 1...-12 are simple items of electrical equipment as specified in EN 60079-11 section 5.7. According to the European Directive 94/9/EC the equipment must be equipped with approved Zener barriers if used in potentially explosive areas. Applicable in Ex zones 1, 2 (1999/92/EC).

The equipment does not bear an Ex marking. The suitability of the Zener barriers is certified in a separate document. Note that the requirements of the IEC 61508 are not met if the NRG 1...-51, NRG 1...-12 + Zener barriers + NRS 1-51 are interconnected!

Technical data

Service pressure

NRG 16-51, PN 40, 32 bar at 238 °C

NRG 17-51, PN 63, 46 bar at 260 °C

NRG 19-51, PN 160, 100 bar at 311 °C

NRG 111-51, PN 320, 183 bar at 357 °C

Mechanical connection

Screwed G $\frac{3}{4}$ A, ISO 228 (NRG 16-51, NRG 17-51, NRG 19-51)

Screwed G1 A, ISO 228 (NRG 111-51)

Materials

Screw-in body: 1.4571 X6 CrNiMoTi 17-12-2

(NRG 16-51, NRG 17-51, NRG 19-51)

Screw-in body: 1.4529 X1NiCrMoCuN25-20-7 (NRG 111-51)

Measuring electrode: 1.4571 X6 CrNiMoTi 17-12-2

(NRG 16-51, NRG 17-51, NRG 19-51)

Measuring electrode: 1.4122 X39CrMo17-1 (NRG 111-51)

Electrode tip: 1.4401 X5 CrNiMo 17-12-2

Electrode insulation: PEEK

(NRG 16-51, NRG 17-51, NRG 19-51)

Electrode insulation: special ceramic (NRG 111-51)

NRG 1...-51: Four-pole connector: polyamide (PA)

NRG 1...-51F: Terminal box 3.2161 G AISi8Cu3

Lengths available

500 mm, 1000 mm, 1500 mm

pH value

Max. admissible: 10 (only NRG 111-51)

Electrical conductivity

Max. admissible: 100 μ S/cm at 25 °C (only NRG 111-51)

Electrical connection

NRG 1-51: Four-pole connector,

cable gland M16

NRG 1...-51F: Aluminium terminal box, cable gland M20

Protection

IP 65 to DIN EN 60529

Admissible ambient temperature

Max. 70°C

Weight

Approx. 1.2 kg (without extension)

(NRG 16-51, NRG 17-51, NRG 19-51)

Approx. 2.1 kg (without extension)

(NRG 16-51F, NRG 17-51F, NRG 19-51F)

Approx. 1.8 kg (without extension) (NRG 111-51)

Approx. 2.7 kg (without extension) (NRG 111-51F)

Dimensions

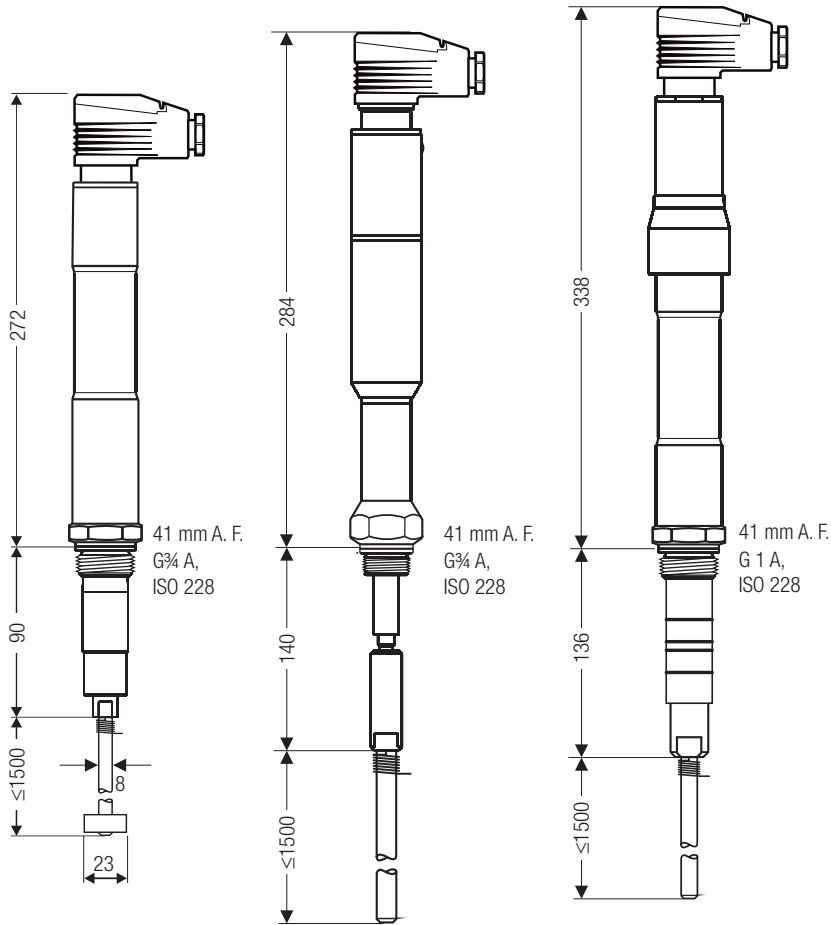

Fig. 1 NRG 16-51, NRG 17-51 with four-pole connector and measuring surface extension

Fig. 2 NRG 19-51 with four-pole connector

Fig. 3 NRG 111-51 with four-pole connector

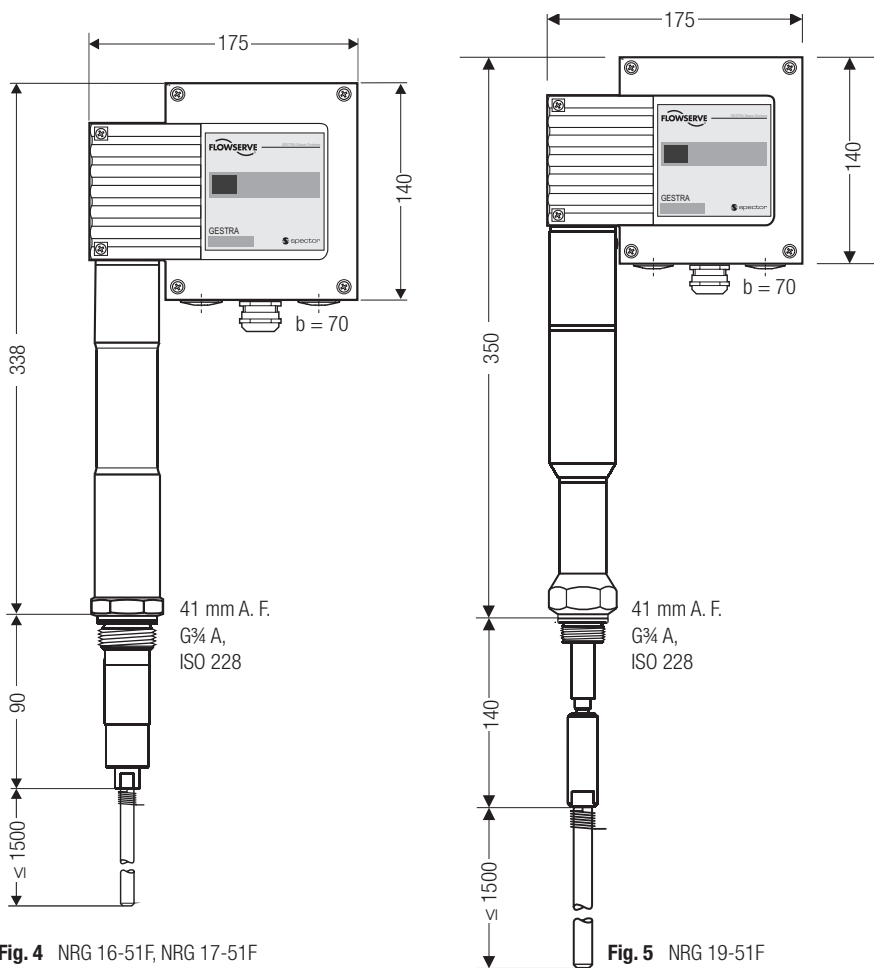

Fig. 4 NRG 16-51F, NRG 17-51F with aluminium terminal box

Fig. 5 NRG 19-51F with aluminium terminal box

Fig. 6 NRG 111-51F with aluminium terminal box

Important Notes

Installation

- One level electrode NRG 1...-51 can be installed together with one GESTRA level electrode, one level switch or transmitter for water level control and limiting in one single protection tube or level pot (inside diameter 100 mm). If the electrode NRG 1...-50 is installed inside the vessel, it must be at least 40 mm away from the upper vent hole.
- The angle of inclination of the electrode must not exceed 45°, with the length of the electrode rod being limited to 1000 mm.
- If used in combination with level switch NRS 1-51 with a response sensitivity of 0.5 μ S/cm please use a measuring surface extension.
- For outdoor installations please use level electrode NRG 1...-51 F. Level electrodes with this suffix (F) feature a terminal box made from aluminium.
- If the level electrode **NRG 111-51** is to be installed in a flanged standpipe DN 50 use only the GESTRA PN 160 hat flange.

Electrical connection

To connect the level electrode please use:

- For the level switch NRS 1-51 with a response sensitivity of 10 μ S: Multi-core screened control cable, min. conductor size 0.5 mm², e. g. LIYCY 4 x 0.5 mm², max. length 100 m.
- For the level switch NRS 1-51 with a response sensitivity of 0.5 μ S: Multi-core double-screened low-capacitance data cable, min. conductor size 0.5 mm², **Li2YCY PiMF 2 x 2 x 0.5 mm², max. length 30 m.**

Order & Enquiry Specification

GESTRA Level electrode type NRG 1...-51
 PN ..., connection, inspection,
 Length supplied,mm

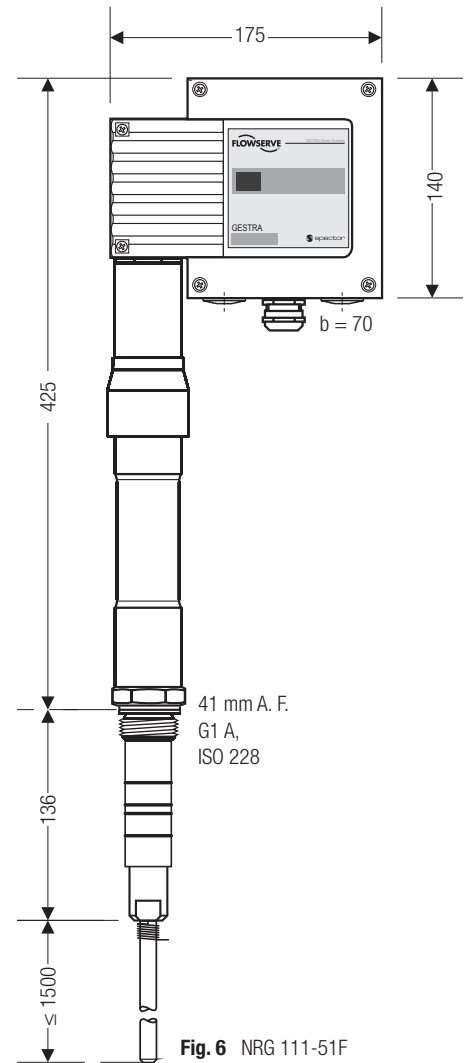

High-Level Alarm

Level Electrode

**NRG 16-51, NRG 17-51,
NRG 19-51, NRG 111-51**

Key

- 1 Flange PN 40, PN 63, PN 160, PN 320
DN 50, DIN EN 1092-01 (single electrode)
Flange PN 40, PN 63, PN 160, DN 100,
DIN EN 1092-01 (combination of electrodes)
- 2 For the approval of the boiler standpipe with connecting flange the relevant regulations must be considered.
- 3 Vent hole
- 4 Electrode tip $d = 8 \text{ mm}$
- 5 Protection tube DN 80
(in France according to AFAQ ≥ 100)
- 6 Low water (LW)
- 7 Reducer DIN 2616-2,
K-88.9x3.2-42.4 x 2.6 W
- 8 High water (HW)
- 9 Electrode distance $\geq 14 \text{ mm}$ (air gap and creepage distance)
- 10 GESTRA hat flange PN 320, DN 50,
DIN EN 1092-01
- 11 Standpipe / connecting flange DN 50
- 13 Protection tube DN 100
- 13 Reducer DIN 2616-2,
K-114.3x3.6-48.3 x 2.9 W
- 14 Level pot $\geq \text{DN } 80$

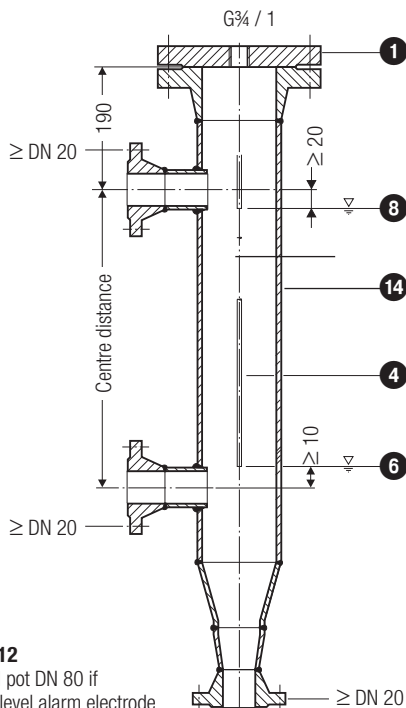

Fig. 12
Level pot DN 80 if high level alarm electrode is installed outside the boiler

Supply in accordance with our general terms of business.

Examples of installation

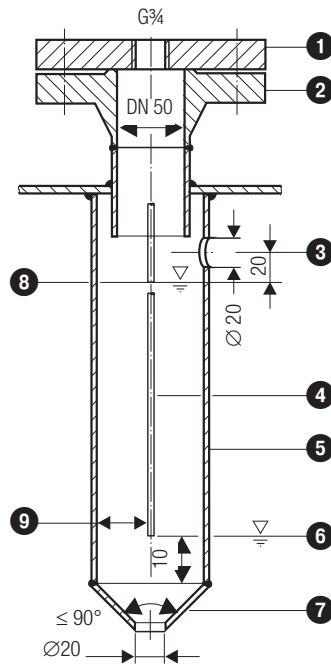

Fig. 7 Protection tube (provided on site) if electrode is used as internal water-level limiter

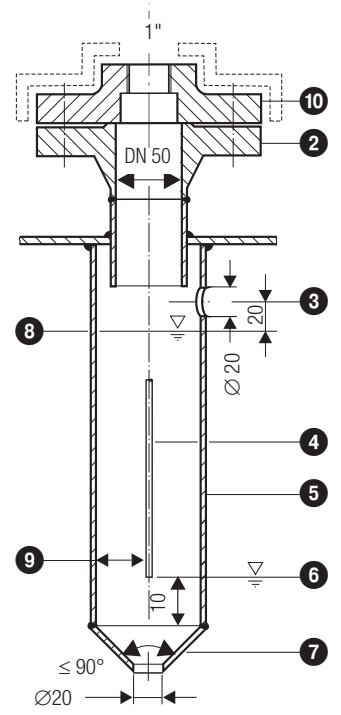

Fig. 8 Protection tube (provided on site) if electrode is used as internal water-level limiter (NRG 111-51)

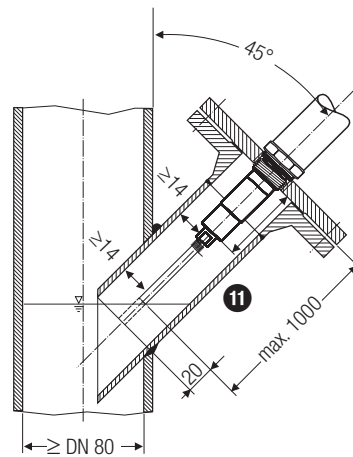

Fig. 9 Inclined installation, e. g. in ascending inlet lines of hot-water installations or vessels
Standpipe / connecting flange DN 50

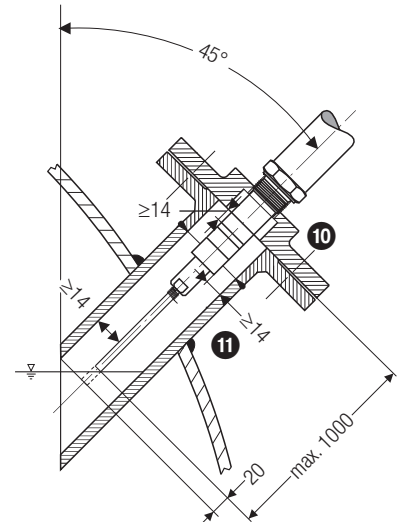

Fig. 10 Inclined installation, e. g. in steam boilers
Standpipe / connecting flange DN 50 (NRG 111-51)

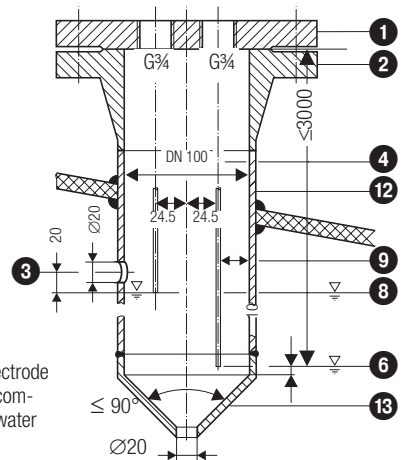

Fig. 11 Protection tube (provided on site) if electrode is used as internal water level-limiter combined with water level control or high water level alarm

GESTRA AG

P. O. Box 10 54 60, D-28054 Bremen
Münchener Str. 77, D-28215 Bremen
Tel. 0049 (0) 421 / 35 03-0, Fax 0049 (0) 421 / 35 03-393
E-mail gestra.ag@flowsolve.com, Web www.gestra.com

