

GESTRA Steam Systems

Product Range B

Conductivity Switch LRS 1-7

LRS 1-7

Description

The conductivity switch LRS 1-7 in conjunction with the conductivity electrode LRG 16-9 constitutes a conductivity monitoring and control system. The electrical conductivity of

- Condensate,
- Boiler feedwater,
- Cooling and cleaning water,
- Boiler water

is monitored. In steam boiler plants the conductivity monitoring & control system is used as limit switch and continuous blowdown controller.

Function

The conductivity electrode LRG 16-9 in conjunction with the conductivity switch LRS 1-7 measures the electrical conductivity of the water to be monitored. The integrated resistance thermometer enables the conductivity electrode LRG 16-9 to measure the water temperature.

The electrical conductivity changes as the water temperature changes. To obtain readings that can be used for comparison the measurement must be based on a standard reference temperature of 25 °C.

The water temperature is measured and the conductivity reading is automatically compensated as a function of the adjusted temperature coefficient T_k (%/°C). If the temperature changes the measured value will be linearly based on 25 °C over the whole measuring range thanks to the temperature compensation.

An adjustable contact triggers a signal when the MAX limit is reached.

A two-point controller is integrated in the conductivity switch so that the equipment can also be used in steam boiler installations. The two-point controller controls a continuous blowdown valve and automatically closes it when the boiler is shut down.

In addition the valve will be opened and closed at regular intervals. This prevents the continuous blowdown valve from getting stuck.

An optional current signal of 4 - 20 mA is available for external processing. The current signal is a function of the conductivity.

A short circuit or wire breakage in the conductivity electrode will trigger an error message in the conductivity switch.

The electrical conductivity is measured in $\mu\text{S}/\text{cm}$. In some countries ppm (parts per million) is used instead. Conversion $1 \mu\text{S}/\text{cm} = 0.5 \text{ ppm}$. The conductivity switch can be adjusted accordingly.

Technical Data

Type approval

TÜV.WUL.xx-xxx

Supply voltage

230 V, +10/-15 %, 50-60 Hz

115 V, +10/-15 %, 50-60 Hz (option)

Input

1 Input for conductivity electrode LRG 16-9

Output

3 volt-free relay contacts, max. contact rating for switching voltages 115 V AC and 230 V AC: resistive/ inductive 4 A.

Provide contactor with interference suppressor (RC combination). Contact material: AgNi 0,15.

1 Current output 4-20 mA as actual value output, max. load 500 Ω (option)

Technical Data - continued -

Measuring range

0.5 to 10000 $\mu\text{S}/\text{cm}$ at 25 °C or
0.25 to 5000 ppm at 25 °C.

Setpoint

adjustable between 0.5 and 9999 $\mu\text{S}/\text{cm}$ or
0.25 to 5000 ppm

MAX limit

adjustable between 0.5 and 9999 $\mu\text{S}/\text{cm}$ or
0.25 to 5000 ppm

Correction factor

adjustable between 0.05 and 5,000, adjustable in increments of 0.001

Temperature coefficient T_k

0.0 - 3.0 % per °C, adjustable in increments of 0.1

Actual value output

4 mA corresponds to 0.5 $\mu\text{S}/\text{cm}$
20 mA corresponds to 10, 200, 500, 1000, 6000,
9999 $\mu\text{S}/\text{cm}$ or 5, 100, 250, 500, 3000, 5000 ppm,
final values adjustable

Purging interval

(continuous blowdown valve is forced to open)
adjustable between 1 h and 24 h in increments of 1 h.

Duration of purging

adjustable between 1 min. and 6 min. in increments of 1 min.

Switching hysteresis

Controller output: - 10 % of the adjusted setpoint W,
Limit MAX: - 3 % of the adjusted MAX limit

Indicators and adjusters

- 1 four-digit, seven-segment indicator, red, for indicating the actual value / setpoint and for status and error messages
- 2 amber LEDs for indicating actual value (X) / setpoint (W)
- 1 red LED for indicating MAX limit
- 2 green LEDs for indicating valve OPEN / CLOSED
- 4 pushbuttons for value and parameter settings

Power consumption

6 VA

Fuse

external 63 mA, slow blow, at 230 V,
external 125 mA, slow blow, at 115 V

Protection

IP 65 to DIN EN 60529

Protection class

2 (totally insulated)

Ambient temperature

Max. 70 °C

Cable entry / Wiring

Cable gland with integral cable clamp, 3 x M 16 x 1.5
1 four-pole screw-type terminal strip for power supply,
1 three-pole screw-type terminal strip for connecting the continuous blowdown valve,
1 three-pole screw-type terminal strip for MAX limit,
1 two-pole screw-type terminal strip for current output 4-20 mA,
Terminal strips detachable, conductor size: 1.5 mm²
1 Sensor jack M12, with 5 poles, A coded, for connecting the conductivity electrode

Cable length

max. 30 m, max. 10 m conductivities from
0.5 - 10 $\mu\text{S}/\text{cm}$

Weight

Approx. 0.8 kg

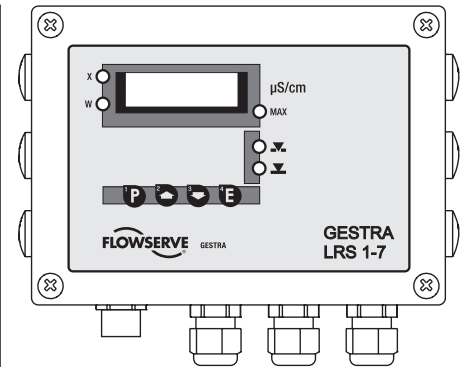

LRS 1-7

Conductivity Switch LRS 1-7

Important Notes

The conductivity switch is designed for wall mounting. The conductivity electrode LRG 16-9 and the conductivity switch are equipped with M 12 sensor plug-in connectors with 5 poles, A coded. For connecting the equipment control cable assemblies (with plug and connector) of various lengths are available as add-on equipment.

Note that the recommended control cable is not UV-resistant and, if installed outdoors, must be protected by a UV-resistant plastic tube or cable duct.

If the above-mentioned control cable assembly is not used, a screened five-core control cable, e. g. Ölflex 110 CH, manufactured by Lapp, 5 x 0.5 mm² must be used for wiring.

Max. cable length between conductivity electrode and switch: 30 m, with conductivities from 0.5 to 10 µS/cm: max. 10 m.

Install an easily accessible disconnecter near the equipment as disconnecting device.

Order & Enquiry Specification

GESTRA Conductivity switch type LRS 1-7, as continuous blowdown controller / limit switch, measuring range 0.5 to 10000 µS/cm or 0.25 to 5000 ppm, Optional extra: Current output 4-20 mA as actual value output, supply voltage: 230 V / 50-60 Hz or 115 V / 50-60 Hz, please state when ordering.

Associated conductivity electrode

- Conductivity electrode LRG 16-9 or conductivity electrodes type ERL, LRG

LV (Low Voltage) Directive and EMC (Electromagnetic Compatibility)

The equipment meets the requirements of the Low Voltage Directive 2006/95/EC and the EMC Directive 2004/108/EC.

ATEX (Atmosphère Explosible)

According to the European Directive 94/9/EC the equipment must not be used in potentially explosive areas.

Key

- 10 M 12 sensor jack, 5 poles, A coded
- 13 M 12 sensor connector, 5 poles, A coded (conductivity electrode)
- 14 Conductivity electrode LRG 16-9
- 15 Conductivity electrode types ERL, LRG (without Pt 100)
- 16 Current output 4-20 mA, load max. 500 Ω (option)
- 17 Limit contact MAX
- 18 Disconnecter
- 19 Continuous blowdown valve (actuator) BAE
- 20 Electric or pneumatic three-way valve

Supply in accordance with our general terms of business.

Electrical connection (continuous blowdown control)

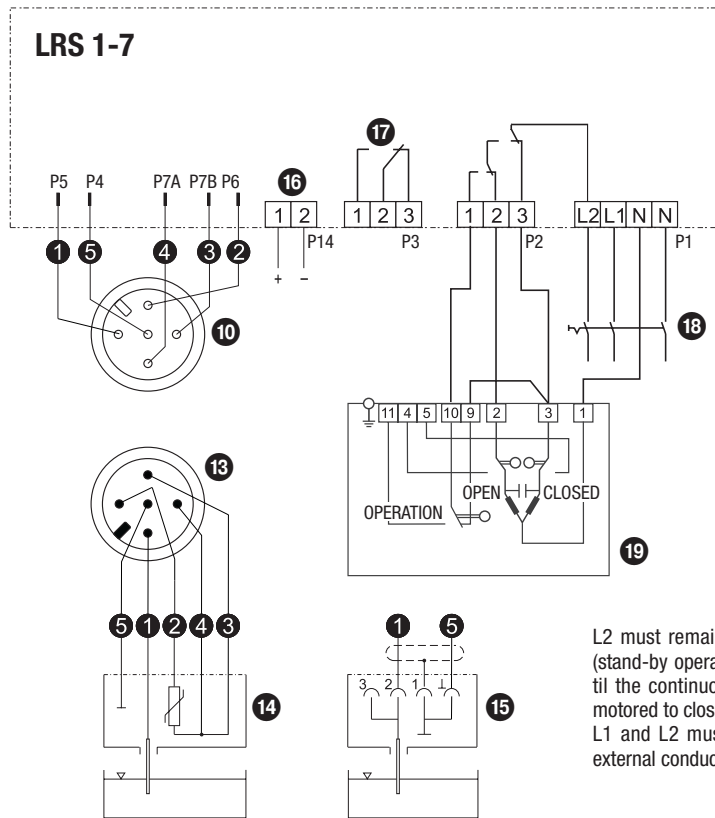

L2 must remain live after the burner (stand-by operation) is shut down until the continuous blowdown valve is motored to close. L1 and L2 must be connected to an external conductor of the same phase.

Electrical connection (water monitoring)

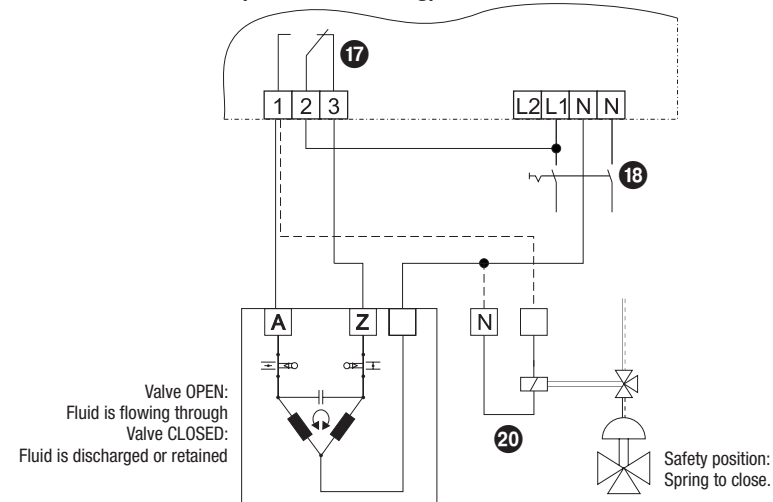

Contacts shown at Power OFF/ limit exceeded condition

Dimensions

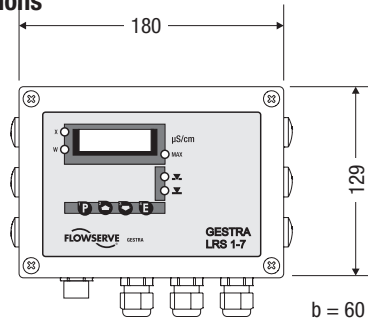

MAX 70°C

%
MAX 95%

IP 65

GESTRA AG

P. O. Box 10 54 60, D-28054 Bremen
Münchener Str. 77, D-28215 Bremen
Telephone 0049 (0) 421 35 03 - 0, Fax 0049 (0) 421 35 03 - 393
E-mail gestra.ag@flowsERVE.com, Internet www.gestra.de



GESTRA