



FLOWSERVE

GESTRA

GESTRA Steam Systems

TRS 5-50

EN

English

Installation & Operating Instructions

819226-03

Temperature Switch TRS 5-50

Contents

Page

Important notes

Usage for the intended purpose.....	4
Function.....	4
Safety note.....	5

Directives and standards

EC Pressure Equipment Directive 97/23/EC	5
Functional Safety acc. to IEC 61508	5
DIN EN 14597	5
Approvals for Marine Applications	5
LV (Low Voltage) Directive and EMC (Electromagnetic Compatibility).....	6
ATEX (Atmosphère Explosible)	6
UL / cUL (CSA) Approval	6
Note on the Declaration of Conformity / Declaration by the Manufacturer CE	6

Functional Safety acc. to IEC 61508

Safety characteristics of the subsystem TRG 5-6. / TRS 5-50	7
Terms and abbreviations	7
Determination of the Safety Integrity Level (SIL) for safety-related systems	8

Technical data

TRS 5-50	9
Name plate / marking	10

In control cabinet: Mounting temperature switch

Dimensions TRS 5-50	11
Key	11
Installation in control cabinet.....	11
Scope of supply	11

In control cabinet: Wiring temperature switch

Wiring diagram for temperature switch TRS 5-50.....	12
Key	12
Connection of supply voltage.....	13
Connection of safety circuit.....	13
Equipment used as safety temperature monitor.....	13
Equipment used as safety temperature limiter, connection of reset/test input	13
Connecting the temperature sensor.....	13
Connection for actual-value output (optional).....	14

Contents - continued -

Page

In the plant: Wiring temperature sensor

Connection for temperature sensor	15
Wiring diagram for temperature sensor	15

Factory setting

16

Changing factory settings

Changing the configuration	16
----------------------------------	----

Commissioning procedure

Start and adjustment of MAX limit	17
---	----

Operation, alarm and test

Indicators and adjusters	18
--------------------------------	----

Troubleshooting

Indication, diagnosis and remedy	19
Measure fluid temperature	20

Check installation and performance

Checking switch-off function at T_{MAX}	20
---	----

Further Notes

Action against high frequency interference	21
Decommissioning / replacing the equipment	21
Disposal	21

Important notes

Usage for the intended purpose

The temperature switch TRS 5-50 is used in conjunction with temperature sensor TRG 5-6.. as safety temperature limiter or monitor, for instance in steam boilers and (pressurised) hot-water plants. When the max. admissible temperature in the superheater or the inlet line is reached, the safety temperature limiter or monitor switches the heating off.

The temperature switch TRS 5-50 can be used in combination with the following temperature sensing electrodes: TRG 5-63, TRG 5-64, TRG 5-65, TRG 5-66, TRG 5-67 and TRG 5-68

Function

A platinum resistance thermometer Pt 100 to EN 60751 is used as temperature sensor for the temperature switch TRS 5-50. A three-wire configuration is used for the electrical connection.

The temperature switch processes the temperature-dependent changes in resistance of the temperature sensor and, during normal operation, the seven-segment LED display shows the adjusted switch-off temperature T_{MAX} (°C) and the actual value T (°C).

The switchpoint for MAX temperature can be variably adjusted within the measuring range. Once the MAX temperature is reached both output contacts of the temperature switch open the safety circuit and the seven-segment LED display for T_{MAX} is flashing.

In addition the relay contact for external signalling equipment is closed.

If the system is configured as **safety temperature monitor**, the temperature switch does not automatically interlock the deactivation of the heating. As soon as the temperature has fallen below the fixed hysteresis, the safety circuit will be closed again.

However, if the system is configured as **safety temperature limiter**, the temperature switch automatically interlocks the deactivation of the heating. Note that once the temperature has fallen below the fixed hysteresis, the equipment must be reset manually or externally in order to close the safety circuit.

Any error or malfunction that occurs in the temperature sensor, the electrical connection or the temperature switch is indicated by the seven-segment LED display and the output contacts will be opened.

An automatic self-testing routine monitors the safety functions in the temperature switch and the temperature sensor. In the event of a malfunction the safety circuit opens and switches the heating off.

Parameter settings can be changed, a MAX temperature alarm can be simulated and the equipment can be reset by operating the rotary button.

For external temperature indication the equipment is optionally available with an actual-value output 4-20 mA.

Important Notes - continued -

Safety note

Safety temperature limiters/monitors are safety devices and must only be installed, wired and commissioned by qualified and competent staff.

Retrofitting and maintenance work must only be performed by qualified staff who - through adequate training - have achieved a recognised level of competence.



Danger

The terminal strips of the equipment are live during operation.

This presents the danger of electric shock!

Always **cut off power supply** to the equipment before mounting, removing or connecting the terminal strips!



Attention

The name plate specifies the technical features of the equipment. Note that any piece of equipment without its specific name plate must neither be commissioned nor operated.

Directives and standards

EC Pressure Equipment Directive 97/23/EC

Safety temperature limiters/monitors are safety accessories as defined in the Pressure Equipment Directive (PED). The temperature switch TRS 5-50 in conjunction with temperature sensors TRG 5-6.. is EC type approved according to EN 12952/EN 12953. These Directives state, among other things, the requirements made on limiting systems and equipment for steam boiler plants and (pressurised) hot-water installations.

Functional Safety acc. to IEC 61508

The temperature switch TRS 5-50 in conjunction with temperature sensors TRG 5-6.. is certified to IEC 61508. This standard describes the functional safety of safety-related electrical/electronic/programmable electronic systems.

The equipment combination TRG 5-6.. + TRS 5-50 corresponds to a type B subsystem with Safety Integrity Level (SIL) 3.

DIN EN 14597

The temperature switch TRS 5-50 in conjunction with temperature sensing electrodes type TRG 5-6.. is type approved according to DIN EN 14597.

DIN EN 14597 describes and specifies the requirements made on safety temperature limiters/monitors.

Approvals for Marine Applications

The temperature switch TRS 5-50 in conjunction with temperature sensors TRG 5-6.. is approved for marine applications.

Directives and Standards - continued -

LV (Low Voltage) Directive and EMC (Electromagnetic Compatibility)

The temperature switch TRS 5-50 meets the requirements of the Low Voltage Directive 2006/95/EC and the EMC Directive 2004/108/EC.

ATEX (Atmosphère Explosible)

According to the European Directive 94/9/EC the temperature switch TRS 5-50 must **not** be used in potentially explosive areas.

UL / cUL (CSA) Approval

The equipment meets the requirements of the Directives: UL 508 and CSA C22.2 No. 14-13, Standards for Industrial Control Equipment. File E243189.

Note on the Declaration of Conformity / Declaration by the Manufacturer C€

For details on the conformity of our equipment according to the European Directives see our Declaration of Conformity or our Declaration of Manufacturer.

The current Declaration of Conformity / Declaration of Manufacturer are available in the Internet under www.gestra.com/documents or can be requested from us.

Functional Safety acc. to IEC 61508

Safety characteristics of the subsystem TRG 5-6.. / TRS 5-50

The temperature switch TRS 5-50 in conjunction with temperature sensors TRG 5-6.. is certified to IEC 61508.

The equipment combination TRG 5-6.. / TRS 5-50 corresponds to a type B subsystem with Safety Integrity Level (SIL) 3. Type B means that the behaviour under fault conditions of the used components cannot be completely determined. The functional safety of the equipment combination refers to the detection and evaluation of the temperature and, as a consequence, the contact position of the output relays.

The design of the equipment combination TRG 5-6.. / TRS 5-50 corresponds to the architecture 1002. This architecture consists of two channels that detect and diagnose faults in each other. If a fault is detected, the equipment combination TRG 5-6.. / TRS 5-50 will go to the safe state, which means that the contacts of both output relays will open the safety circuit.

The equipment is suitable for machines and installations up to performance level "e".

Safety characteristics	SIL	Architecture	Lifetime (a)	Proof Test Interval (a)
General	3	1002	20	20
	SFF	PFD _{av}	PFH _{av}	λ _{DU}
Temperature switch TRS 5-50 alone	99.6 %	2.69* x 10 ⁻⁵	3.07 x 10 ⁻⁹	2.95 x 10 ⁻⁹ /h
Temperature switch TRS 5-50 in combination with temperature sensor TRG 5-6..	98.2 %	1.71* x 10 ⁻⁴	1.96 x 10 ⁻⁸	1.95 x 10 ⁻⁸ /h

* if required once a year

Fig. 1

Terms and abbreviations

Terms Abbreviations	Description
Safety Integrity Level SIL	Classification of the Safety Integrity Level acc. to IEC 61508
Lifetime (a)	Functional safety: Lifetime in years
Safe Failure Fraction SFF	Percentage of failures without the potential to put the safety-related system into a dangerous state
Probability Failure per Demand (Low Demand) PFD _{av}	Average probability of failure on demand for low demand mode (once a year)
Probability Failure per Hour PFH _{av}	Probability failure per hour
λ _{DU}	Failure rate for all dangerous undetected failures (per hour) of a channel of a subsystem

Fig. 2

Determination of the Safety Integrity Level (SIL) for safety-related systems

Temperature sensor, temperature switch and actuators (auxiliary contactor in safety circuit) are sub-systems and together constitute a safety-related system that executes a safety function.

The specification of the safety-related characteristics **Fig. 1** refers to the temperature sensor and the temperature switch including the output contacts. The actuator (e. g. an auxiliary contactor in the safety circuit) is installation specific and, according to IEC 61508, must be considered separately for the whole safety-related system.

Table **Fig. 3** shows the dependence of the Safety Integrity Level (SIL) on the average probability of failure on demand of a safety function for the **whole** safety-related system (PFD_{sys}). The "Low demand mode" is here considered for a safety temperature limiter, which means that the frequency of demands for operation of the safety-related system is no greater than one per year.

Low demand mode PFD_{sys}	Safety Integrity Level (SIL)
$\geq 10^{-5} \dots < 10^{-4}$	4
$\geq 10^{-4} \dots < 10^{-3}$	3
$\geq 10^{-3} \dots < 10^{-2}$	2
$\geq 10^{-2} \dots < 10^{-1}$	1

Fig. 3

The table in **Fig. 4** indicates the attainable Safety Integrity Level (SIL) as a function of the Safe Failure Fraction (SFF) and the Hardware Fault Tolerance (HFT) for safety-related systems.

Hardware Fault Tolerance (HFT) for type B			Safe Failure Fraction (SFF)
0	1	2	
	SIL 1	SIL 2	< 60 %
SIL 1	SIL 2	SIL 3	60 % – < 90 %
SIL 2	SIL 3	SIL 4	90 % – < 99 %
SIL 3	SIL 4	SIL 4	≥ 99 %

Fig. 4

Technical data

TRS 5-50

Supply voltage

24 VDC +/- 20%, 0.3 A;
100-240 VAC + 10/- 15%, 47-63 Hz, 0.2 A

Fuse

external M 0.5 A

Power consumption

7 VA

Wiring temperature sensor

1 input for temperature sensor TRG 5-63, TRG 5-64, TRG 5-65, TRG 5-66, TRG 5-67 and TRG 5-68, (platinum resistance thermometer Pt 100 to EN 60751), with 3 poles and screen.

Connection for external test & reset

1 volt-free input, 24 VDC, for connecting external reset and test button.

Safety circuit

2 volt free make contacts, 6 A 250 V AC / 30 V DC $\cos \varphi = 1$ (external slow-blow fuse 2 A).
Inductive loads must be provided with interference suppressors (RC combinations) as specified by the manufacturer.

Signal outputs

1 analogue output 4-20 mA (0 – 650 °C), max. load 500 ohm, e. g. for actual-value indication (optional).
1 voltage-free output for instantaneous external signalling, 24 V DC, max. 100 mA (semiconductor output).

Limit range

0 °C to 600 °C

Reset hysteresis

-3 K, fixed setting.

Indicators and adjustors

1 rotary button with integrated pushbutton for setting the MAX temperature and testing and resetting the equipment.
1 pushbutton (hidden) for enabling the setting.
1 two-pole code switch for configuration.
2 seven-segment three-digit LED display for MAX temperature and actual value.

Housing

Housing material: base: polycarbonate, black; front: polycarbonate, grey

Conductor size: 1 x 4.0 mm² solid per wire or

1 x 2.5 mm² per stranded wire with sleeve to DIN 46228 or

2 x 1.4 mm² per stranded wire with sleeve to DIN 46228;

Terminal strips can be detached

Fixing of housing: Mounting clip on supporting rail TH 35, EN 60715

Electrical safety

Degree of contamination: 2, overvoltage category III to EN 61010-01.

Protection

Housing: IP 40 to EN 60529

Terminal strip: IP 20 to EN 60529

Weight

approx. 0.5 kg

TRS 5-50 - continued -

Ambient temperature

when system is switched on: 0 ° ... 55 °C
 during operation: -10 ... 55 °C

Transport temperature

-20 ... +80 °C (<100 hours), defrosting time of the de-energized equipment before it can be put into operation: 24 hours: 24 hours.

Storage temperature

-20 ... +70 °C, defrosting time of the de-energized equipment before it can be put into operation: 24 hours.

Relative humidity

max. 95%, no moisture condensation

Site altitude

max. 2000 m

Approvals:

EC Type approval

PED Pressure Equipment Directive 97/23/EC, EN 12952-11, EN 12953-09: Requirements made on limiting equipment for boilers.

Functional Safety
 SIL 3

acc. to EN 61508: Functional safety of safety-related electrical/ electronic/programmable electronic systems

Type approval

DIN EN 14597:
 Requirements made on safety temperature limiters/monitors
 DIN Registration number DIN STW/STB 1230

Marine applications

Rules and guidelines of classification societies, GL 47399-12 HH

UL /cUL (CSA) Approval

Approval UL 508 and CSA C22.2 No. 14-13, Standards for Industrial Control Equipment. File E243189.

Name plate / marking

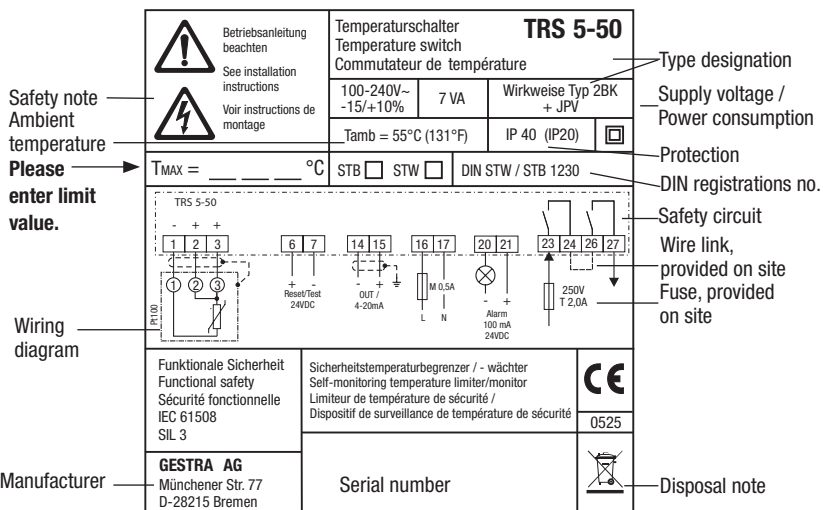

Fig. 5

In control cabinet: Mounting temperature switch

Dimensions TRS 5-50

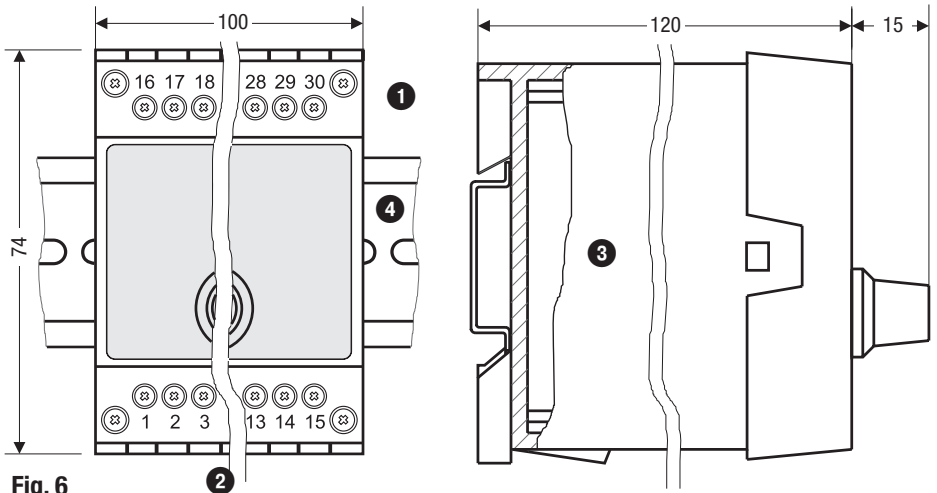

Fig. 6

Key

- | | |
|------------------------|--|
| 1 Upper terminal strip | 3 Housing |
| 2 Lower terminal strip | 4 Supporting rail type TH 35, EN 60715 |

Installation in control cabinet

The temperature switch TRS 5-50 is clipped onto the support rail type TH 35, EN 60715 in the control cabinet. **Fig. 6 4**

Please enter the defined limit value on the nameplate before mounting the equipment.

Scope of supply

TRS 5-50

- 1 Temperature switch TRS 5-50
- 1 Installation & operating manual

In control cabinet: Wiring temperature switch

Wiring diagram for temperature switch TRS 5-50

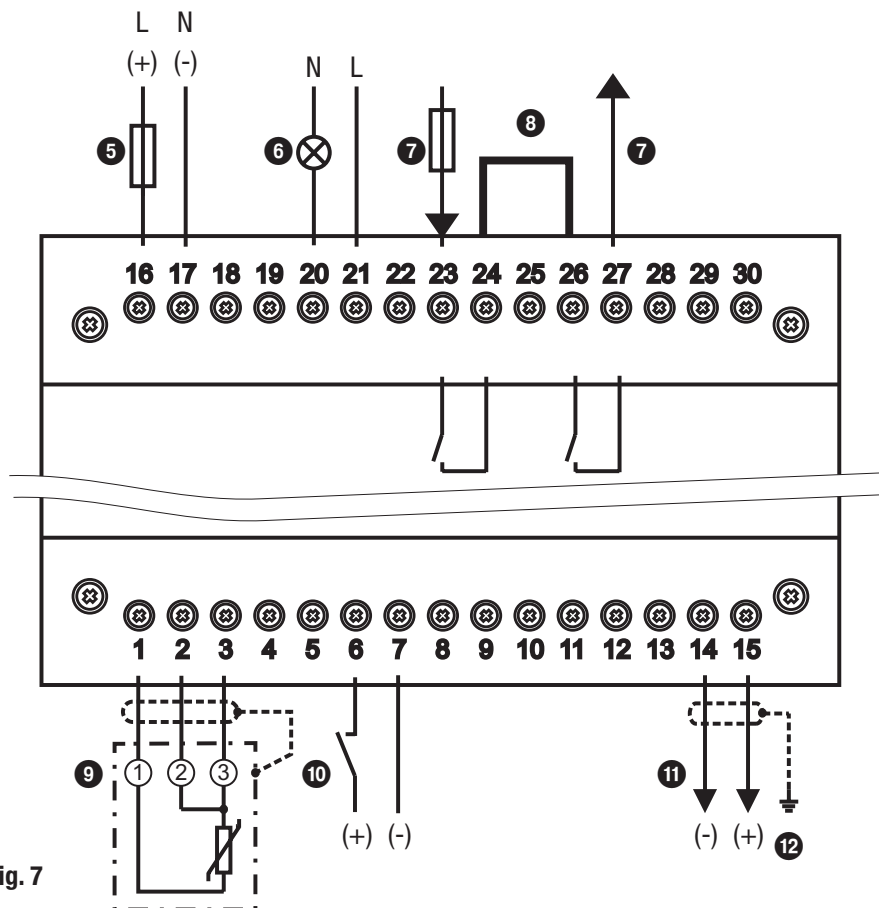

Fig. 7

Key

- 5** Connection of supply voltage with fuse 0.5 A (semi-delay) provided on site
- 6** Signal output for external alarm 24 V DC 100 mA (semiconductor output)
- 7** Safety circuit, input and output
- 8** Wire link, on site, if equipment is used as safety temperature limiter acc. to TRD, EN 12952 / EN 12953
- 9** Wiring diagram for temperature sensor
- 10** Reset/test input, 24 VDC
- 11** Actual value output 4-20 mA (0 – 650 °C) (optional)
- 12** Central earthing point (CEP) in control cabinet

In control cabinet: Wiring temperature switch - continued -

Connection of supply voltage

The equipment is supplied with 24 V DC or 100 - 240 V AC and fused with an external semi-delay fuse 0.5 A.

For the supply of the temperature switch TRS 5-50 with 24 V DC use a safety extra-low voltage (SELV) power supply unit.

Connection of safety circuit

The safety circuit (make contacts of output relays) is opened via terminals 23/24 and 26/27 of the temperature switch. In order for the equipment to be used as safety temperature monitor/safety temperature limiter and to attain Safety Integrity Level SIL 3 the logical AND function of the output contacts must be performed externally (e. g. through series connection of contacts via wire link between terminals 24 and 26).

Provide a slow-blow fuse 2 A for the output contacts (terminals 23/24 and 26/27) of the safety circuit.

Equipment used as safety temperature monitor

If the system is configured as safety temperature monitor, the temperature switch does not automatically interlock the deactivation of the heating. As soon as the temperature has fallen below the non-adjustable hysteresis, the safety circuit will be closed again.

Equipment used as safety temperature limiter, connection of reset/test input

If the system is configured as safety temperature limiter, the temperature switch automatically interlocks the deactivation of the heating. Note that once the temperature has fallen below the non-adjusted hysteresis, the equipment must be reset manually or externally in order to close the safety circuit.

The equipment can be tested or reset externally by means of a voltage pulse at the reset/test input.

For this purpose connect a 24 V DC voltage source with pushbutton to terminals 6 and 7.

For the connection use screened multi-core control cable with a min. conductor size 0.25 mm², e. g. LiYCY 2 x 0.25 mm², max. length 10 m.

Connecting the temperature sensor

To connect the equipment use screened multi-core control cable with a min. conductor size 0.5 mm², e. g. LiYCY 3 x 0.5 mm², max. length: 100 m.

Wire terminal strip in accordance with the wiring diagram. **Fig. 7**

Note that **only** the cable gland of the temperature sensor provides the screen.

In control cabinet: Wiring temperature switch - continued -

Connection for actual-value output (optional)

For the connection use screened multi-core control cable with a min. conductor size 0.5 mm², e. g. LiYCY 2 x 0.5 mm², max. length 100 m. The current output 4 - 20 mA corresponds to a temperature of 0 – 650 °C.

Please observe the max. load of 500 ohm.

Wire terminal strip (terminals 14/15) in accordance with the wiring diagram. **Fig. 7**

Do not use this output for activating safety circuits.

Connect the screen **only once** to the central earthing point (CEP) in the control cabinet.

Connection for signal output

To connect external signalling equipment use screened multi-core control cable with a min. conductor size 0.5 mm², e. g. LiYCY 2 x 0.5 mm², max. length: 100 m. In the event of an alarm or error message, the signal output (terminals 20, 21) closes.

Do not use this output for activating safety circuits.



Attention

- Fuse the temperature switch TRS 5-50 with an external semi-delay fuse 0.5 A.
- Any item of equipment that you want to connect to the terminals 6/7, 14/15 and 20/21 of the temperature switch must be electrically isolated from dangerous contact voltages as per DIN EN 61140, e. g. through double or reinforced isolation according to DIN EN 61010-1 or DIN EN 60730-1 or DIN EN 60950-1.
- To protect the relay contacts fuse safety circuit with 2 A (slow blow).
- When switching off inductive loads, voltage spikes are produced that may impair the operation of control and measuring systems. Connected inductive loads must be provided with suppressors such as RC combinations as specified by the manufacturer.
- When used as safety temperature monitor/ safety temperature limiter according to TRD, EN 12952 / EN 12953 connect terminals 24 and 26 by adding a wire link.
- Make sure that connecting cables leading to the temperature sensor and/or any other external equipment are segregated and run separately from power cables.
- Do not use unused terminals as support point terminals.

Tools

- Screwdriver for slotted screws, size 3.5 x 100 mm, completely insulated according to VDE 0680-1.

In the plant: Wiring temperature sensor

Connection for temperature sensor

The temperature switch TRS 5-50 is designed for use in conjunction with temperature sensors TRG 5-63, TRG 5-64, TRG 5-65, TRG 5-66, TRG 5-67 and TRG 5-68.

To connect the equipment use screened multi-core control cable with a min. conductor size 0.5 mm², e. g. LiYCY 3 x 0.5 mm², max. length: 100 m.

Note that **only** the cable gland of the temperature sensor provides the screen.



Attention

- Please follow the instructions given in the installation & operating manual for the TRG 5-6x.
- Make sure that connecting cables leading to the equipment are segregated and run separately from power cables.

Wiring diagram for temperature sensor

TRG 5-63, TRG 5-65,
TRG 5-66, TRG 5-67

TRG 5-64
TRG 5-68

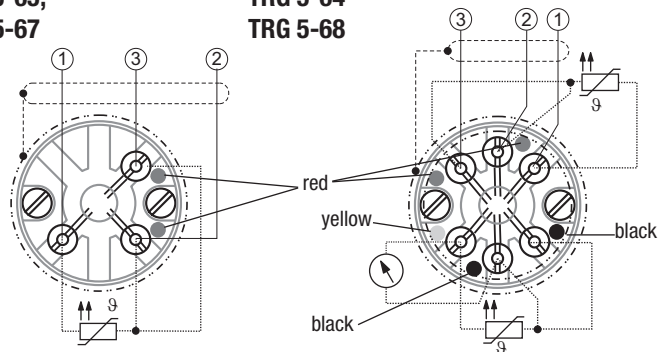

Fig. 8



Note

Additional equipment such as indicating devices can be connected to the terminals marked in yellow and black of the TRG 5-64 and TRG 5-68 .

Factory setting

Temperature Switch TRS 5-50

- MAX limit = 25 °C
- Reset hysteresis: -3 K (fixed setting)
- Configuration: **Safety temperature monitor**
- Code switch 13 : S1, S2 OFF

Changing factory settings



Danger

The upper terminal strip of the equipment is live during operation.
This presents the danger of electric shock!

Always cut off power supply to the equipment before mounting, removing or connecting the terminal strips!

Changing the configuration

The code switch 13 setting determines the configuration of the temperature switch (safety temperature monitor or limiter).

If you want to configure the temperature switch as **safety temperature limiter** please proceed as follows:

- Cut off supply voltage.
- **Lower terminal strip:** Unscrew left and right fixing screws and remove the terminal strip. **Fig. 9**
- Set **S1 and S2** of the code switch 13 to **ON = safety temperature limiter**.
- Attach lower terminal strip and fasten fixing screws.
- Apply supply voltage. Equipment is restarted.

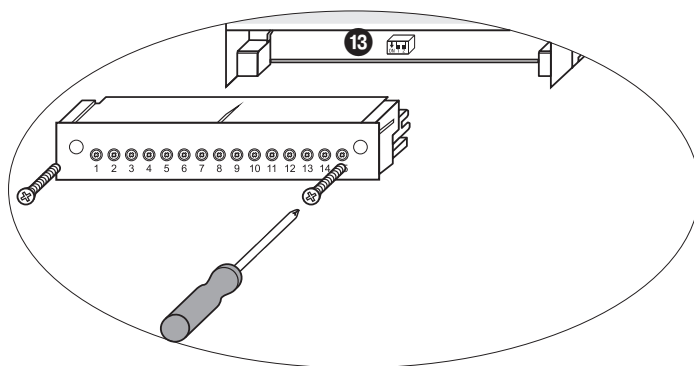

Fig. 9



Note

Please indicate on the nameplate whether the temperature switch is used as safety temperature **monitor** or as safety temperature **limiter**.

Commissioning procedure

Start and adjustment of MAX limit

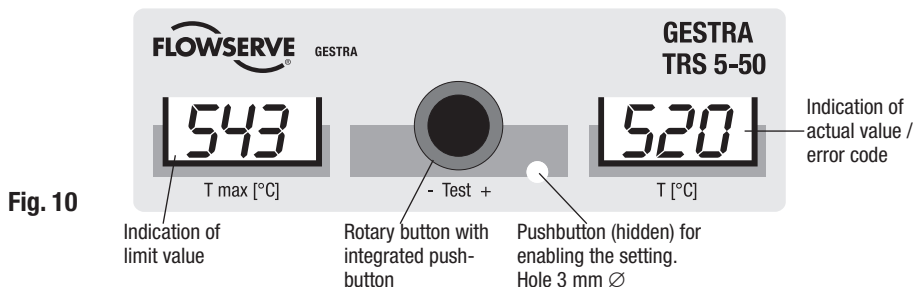

Fig. 10

Start		
Status and action	Display	Function
Switch on supply voltage.	All segments and decimal points of the displays for T_{MAX} and T are tested one after another. They all light up once and then go out.	System and segment test, takes approx. 15 sec. The system then switches back to normal operating mode.
Please observe the system and segment test. If segments or points are missing replace the temperature switch.		
Actual value T (°C) below limit T_{MAX} (°C)	Display T_{MAX} (°C)	Indication of the adjusted limit
	Display T (°C) Actual value	Indication of the actual value
Actual value T (°C) above limit T_{MAX} (°C)	Display T_{MAX} (°C) is flashing	Safety temp. monitor: Safety circuit open, signal output closed
	Display T (°C) Actual value	Safety temp. limiter: Safety circuit open and interlocked, signal output closed

Adjusting the MAX limit		
Activity	Seven-segment displays	Function
Use a 2.5 mm pin to press the (hidden) pushbutton	T_{MAX} (°C): Indication of limit value, first digit (000) is flashing.	Enables the setting of the limit values.
	T (°C): Indication of limit value	
During input both displays (T_{max} and T) show the limit value. Should these two indicated values differ from each other replace the temperature switch.		
Turn rotary button.	First digit (000) flashing.	Set the limit value. To increase the value turn rotary button to the right, to decrease turn it to the left.
Press push-button. Each time you press the button the system moves to the next digit.	Second or third digit is flashing. (from left to right)	
Press push-button.	T_{MAX} (°C): Indication of limit value	Confirm your input. Enter the limit value on the nameplate.
	T (°C): Indication of the actual value	
<i>If no operation is performed:</i>	After 10 sec. the system switches back to normal operating mode.	

Operation, alarm and test

Indicators and adjustors

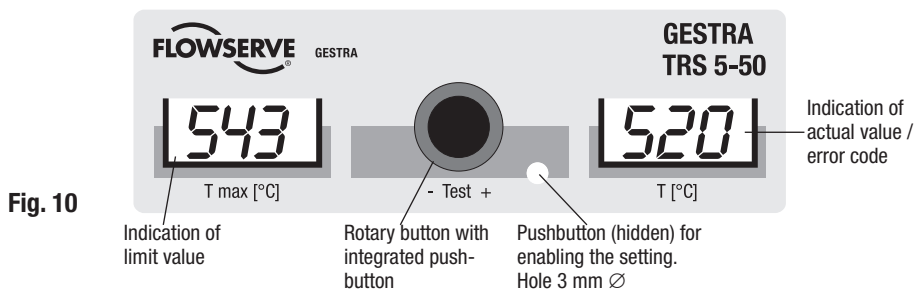

Fig. 10

Operation		
Status and action	Display	Function
Actual value T (°C) below limit T _{MAX} (°C)	Display T _{MAX} (°C)	Indication of the adjusted limit
	Display T (°C) Actual value	Indication of the actual value

Alarm		
Actual value T (°C) above limit T _{MAX} (°C)	Display T _{MAX} (°C) is flashing	Safety temp. monitor: Safety circuit open, signal output closed
	Display T (°C) Actual value	Safety temp. limiter: Safety circuit open and interlocked, signal output closed

Safety temperature limiter: Reset alarm		
Actual value T (°C) must be 3 °C below limit T _{MAX} (°C) Press the pushbutton of the rotary button of the temperature switch or the external reset/test button.	Display T _{MAX} (°C) is flashing	Safety circuit closed, signal output open.
	Display T (°C) Actual value	

Safety temperature monitor: Test		
Press the pushbutton of the rotary button of the temperature switch or the external reset/test button. When you release the button the system switches back to normal operating mode.	T _{MAX} (°C): Indication of limit value is flashing.	While pushbutton is held down: Safety circuit open, signal output closed
	T (°C): Indication of limit value	Replace the temperature switch if the test does not finish successfully.

Safety temperature limiter: Test		
Press the pushbutton of the rotary button of the temperature switch or the external reset/test button. Press again the pushbutton or the external reset/test button to reset the system.	T _{MAX} (°C): Indication of limit value is flashing.	Safety circuit open and interlocked, signal output closed. After pressing the button twice: Safety circuit closed, signal output open.
	T (°C): Indication of limit value	Replace the temperature switch if the test does not finish successfully.

Troubleshooting

Indication, diagnosis and remedy



Attention

Before carrying out the fault diagnosis please check:

Supply voltage:

Is the equipment supplied with the voltage specified on the name plate?

Wiring:

Is the wiring in accordance with the wiring diagram?

Faults indicated by the seven-segment display on the right side		
Error code	Error	Remedy
E.01	Temperature sensor defective, temperature reading too low	Check whether the temperature sensor outputs correct readings (see Fig. 11). If there are any deviations please replace the measuring element with a new one. Check the sensor lines (short circuit, interruption?).
E.02	Temperature sensor defective, temperature reading too high	
E.03 ... E.06 and E.08	Temperature switch defective. An error was detected during one or more self-testing routine(s).	Switch the temperature switch off and on again. If the error code re-appears, replace the temperature switch.
E.07	The code switch 13 setting is incorrect.	Set the code switch according to the desired equipment function.
When contacting our Technical Service team please state the indicated error code.		
In the event of a malfunction a MAX alarm will be triggered.		

Troubleshooting - continued -

Measure fluid temperature

Use table **Fig. 11** to ascertain the current temperature of the fluid via the resistance value of the Pt 100 directly on the temperature sensor.

Please follow the instructions given in the installation & operating manual for the TRG 5-6x.

°C	0	10	20	30	40	50	60	70	80	90	100	Ω/deg
0	100.00	103.90	107.79	111.67	115.54	119.40	123.24	127.07	130.89	134.70	138.50	0.385
100	138.50	142.28	146.06	149.82	153.57	157.32	161.04	164.76	168.47	172.16	175.84	0.373
200	175.84	179.51	183.17	186.82	190.46	194.08	197.70	201.30	204.88	208.46	212.03	0.361
300	212.03	215.58	219.13	222.66	226.18	229.69	233.19	236.67	240.15	243.61	247.06	0.350
400	247.06	250.50	253.93	257.34	260.75	264.14	267.52	270.89	274.25	277.60	280.93	0.338
500	280.93	284.26	287.57	290.87	294.16	297.43	300.70	303.95	307.20	310.43	313.65	0.327
600	313.65	316.86	320.05	323.24	326.41	329.57	332.72	335.86	338.99	342.10	345.21	0.315
700	345.21	348.30	351.38	354.45	357.51	360.55	363.59	366.61	369.62	372.62	375.61	0.304
800	375.61	378.59	381.55	384.50	387.45	390.38						0.295

Basic values of the measuring resistors according to IEC 751 for Pt100.

Fig. 11



Attention

Please replace the measuring element if the temperature measured by the temperature sensor deviates from the plant temperature.

The measuring element must also be replaced by a new one if a malfunction occurred and the rated service pressure and temperature limits were exceeded.

Check installation and performance

Checking switch-off function at T_{MAX}

Check the switch-off function at T_{MAX}

- during commissioning
- **once a year**
- whenever you exchange the temperature sensing element
- whenever you exchange the temperature switch

To test the switch-off function at T_{MAX} exceed the adjusted temperature limit. The equipment must respond as if there were an alarm.

Safety temp. monitor: Safety circuit open, signal output closed

Safety temp. limiter: Safety circuit open and **interlocked**, signal output closed.

Further Notes

Action against high frequency interference

High frequency interference can occur for example as a result of out-of-phase switching operations. Should such interference occur and lead to sporadic failures, we recommend the following actions in order to suppress any interference.

- Provide inductive loads with RC combinations according to manufacturer's specification to ensure interference suppression.
- Make sure that all connecting cables leading to the conductivity electrode or to the conductivity transmitter are segregated and run separately from power cables.
- Increase the distance to sources of interference.
- Check the connection of the screen of the temperature sensor.
- HF interference suppression by means of hinged-shell ferrite rings.

Decommissioning / replacing the equipment

- Switch off supply voltage and **cut off power supply to the equipment!**
- Lower and upper terminal strips: Unscrew left and right fixing screws and remove the terminal strip. **Fig. 12**
- Release the white fixing slide at the bottom of the equipment and take the equipment off the supporting rail.

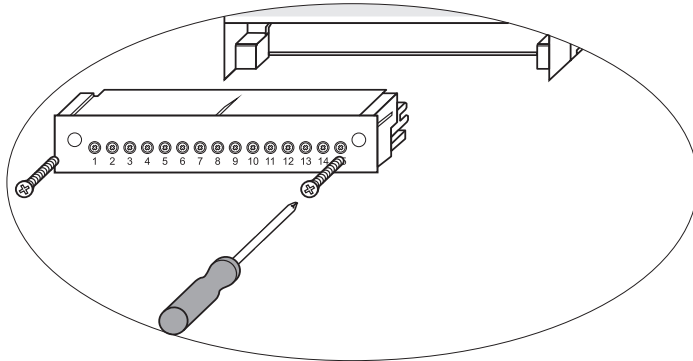

Fig. 12

Disposal

For the disposal of the equipment observe the pertinent legal regulations concerning waste disposal.

If faults occur that are not listed above or cannot be corrected, please contact our service centre or authorized agency in your country.



GESTRA

Agencies all over the world:

www.gestra.com

Great Britain

Flowserve GB Limited

Abex Road
Newbury, Berkshire RG14 5EY
Tel. 0044 16 35 / 46 99 90
Fax 0044 16 35 / 3 60 34
E-Mail gestraukinfo@flowserve.com
Web www.flowserve.com

Singapore

Flowserve Pte. Ltd.

12 Tuas Avenue 20
Singapore 63882
Tel. 0065 / 68 79 89 00
Fax 0065 / 68 62 49 40
E-Mail fcd_gestra_singapore@flowserve.com
Web www.gestra.com

South Africa

Flowserve SA (Pty) Ltd.

Unit No. 1
Director Road
Spartan Extension 2
Kempton Park 1613
Tel. 0027 11 / 9 23 73 00
Fax 0027 11 / 9 74 64 20
E-Mail tvniekerk@flowserve.com
Web www.flowserve.com

USA

Flowserve GESTRA U.S.

2341 Ampere Drive
Louisville, KY 40299
Tel. 001 502 / 267-22 05
Fax 001 502 / 266-53 97
E-Mail fcd-gestra-usa@flowserve.com

GESTRA AG

P. O Box 10 54 60, D-28054 Bremen
Münchener Str. 77, D-28215 Bremen
Tel. 0049 (0) 421 / 35 03-0
Fax 0049 (0) 421 / 35 03-393
E-mail gestra.ag@flowserve.com
Web www.gestra.com

