



**FLOWERVE**

**GESTRA**

## **GESTRA Steam Systems**

# **NRS 1-54**

# **NRS 1-55**

**EN**  
English

### **Installation & Operating Instructions** **819178-00**

Level Switch NRS 1-54

Level Switch NRS 1-55

# Contents

Page

## Important notes

Usage for the intended purpose .....	4
Function .....	4
Safety note .....	5

## Directives and standards

VdTÜV Bulletin "Wasserstand 100" (= Water Level 100) .....	6
LV (Low Voltage) Directive and EMC (Electromagnetic Compatibility) .....	6
ATEX (Atmosphère Explosible) .....	6
Note on the Declaration of Conformity / Declaration by the Manufacturer <b>CE</b> .....	6

## Technical data

NRS 1-54, NRS 1-55 .....	7 – 8
Scope of supply .....	8

## In control cabinet: Mounting level switch

Dimensions NRS 1-54, NRS 1-55 .....	9
Key .....	9
Installation in control cabinet .....	9
Name plate / marking .....	10

## In control cabinet: Wiring level switch

Wiring diagram for level switch NRS 1-54, NRS 1-55 .....	11
Key .....	11
Connecting supply voltage .....	12
Connecting output contacts .....	12
Connecting level electrode .....	12
Tools .....	12

## In the plant: Wiring level electrode

Level switch NRS 1-54: Connecting several level electrodes (fill control) .....	13
Key .....	13
Level switch NRS 1-55: Connecting several level electrodes (fill control) .....	14
Key .....	14
Connecting level electrode .....	15

# Contents - continued -

Page

## Basic settings

Factory setting .....	15
-----------------------	----

## Commissioning procedure

Changing response sensitivity and function .....	16
Changing response sensitivity.....	16
Changing function.....	17
Level switch NRS 1-54: Checking switchpoint and function .....	18 - 19
Level switch NRS 1-55: Checking switchpoint and function .....	20 - 21

## Operation, alarm and test

Level switch NRS 1-54: Indications and operation.....	22
Level switch NRS 1-55: Indications and operation.....	23

## Further notes

Protection against high frequency interference .....	24
Decommissioning / replacing the equipment .....	24
Disposal.....	24

## Important Notes

### Usage for the intended purpose

The level switch NRS 1-54, NRS 1-55 in conjunction with level electrodes NRG 1.-.. and ER 5. is used as water level controller, for instance in steam boilers, (pressurized) hot-water installations as well as condensate and feedwater tanks. The level switch detects and indicates in addition a MIN or a MAX water level.

The level switch NRS 1-54, NRS 1-55 can be used in combination with the following level electrodes:

Level electrodes				
NRG 10-52, NRG 16-52 Electrode with 4 rods	NRG 16-36 Electrode with 4 rods	NRG 16-4 Electrode with 1 rod	ER 50 Electrode with 4 rods	ER 56 Electrode with 4 rods

### Function

The operation of the level switch NRS 1-54, NRS 1-55 is based on the conductive measuring principle using the electrical conductivity of water. The level switch is designed for different electrical conductivities and for connecting three level electrode rods.

The level switch works as on-off water level controller (for fill or discharge control) and indicates in addition when the preset MAX or MIN water level (MAX: NRS 1-54; MIN: NRS 1-55) is reached.

The length of the associated electrode rods determines the switchpoints for water level control and MIN or MAX water level.

The equipment monitors the water level by sensing whether the electrode tips are exposed or immersed and - by energizing or de-energizing the controller output contact - switches the feedwater pump on or off. The LED "Pump" is illuminated when the feedwater pump is switched on by the level switch.

The level switch detects that the MIN or MAX water level is reached when the corresponding electrode rod is exposed or submerged. After the de-energizing delay has elapsed, the MIN / MAX output contact is switched over. At the same time the MIN or the MAX LED changes from green to red.

A MIN or MAX alarm can be simulated by pressing the button "Test".

## Important Notes - continued -

### Safety note

The equipment fulfils a safety function and must only be installed, wired and commissioned by qualified and competent staff.

Retrofitting and maintenance work must only be performed by qualified staff who - through adequate training - have achieved a recognised level of competence.



#### Danger

The terminal strips of the equipment are live during operation.

This presents the danger of electric shock!

**Always cut off power supply** to the equipment before mounting, removing or connecting the terminal strips!



#### Attention

The name plate specifies the technical features of the equipment. Note that any piece of equipment without its specific name plate must neither be commissioned nor operated.

## Directives and Standards

### VdTÜV Bulletin “Wasserstand 100” (= Water Level 100)

The level switch NRS 1-54, NRS 1-55 in conjunction with level electrodes NRG 10-52, NRG 16-52; NRG 16-36, NRG 16-4 and ER 5.-1 is type approved to VdTÜV Bulletin “Water Level 100”. The VdTÜV Bulletin “Wasserstand (= Water Level) 100” specifies the requirements made on water level control and limiting equipment for boilers.

### LV (Low Voltage) Directive and EMC (Electromagnetic Compatibility)

The equipment meets the requirements of the Low Voltage Directive 2006/95/EC and the EMC Directive 2004/108/EC.

### ATEX (Atmosphère Explosible)

According to the European Directive 94/9/EC the equipment must **not** be used in explosion risk areas.



#### Note

The level electrodes NRG 10-52, NRG 16-52, NRG 16-36, NRG 16-4 and ER 5.-1 are simple items of electrical equipment as specified in EN 60079-11 section 5.7. According to the European Directive 94/9/EC the equipment must be equipped with approved Zener barriers if used in potentially explosive areas. Applicable in Ex zones 1, 2 (1999/92/EC). The equipment does not bear an Ex marking. The suitability of the Zener barriers is certified in a separate wiring diagram provided by the manufacturer.

### Note on the Declaration of Conformity / Declaration by the Manufacturer **CE**

For details on the conformity of our equipment according to the European Directives see our Declaration of Conformity or our Declaration of Manufacturer. The current Declaration of Conformity / Declaration of Manufacturer are available in the Internet under [www.gestra.com/documents](http://www.gestra.com/documents) or can be requested from us.

## Technical Data

### NRS 1-54, NRS 1-55

#### Supply voltage

24 VDC +/- 20 %

#### Fuse

external 0.5 A (semi-delay)

#### Power consumption

2 VA

#### Connection of level electrode

3 inputs for level electrode NRG 10-52, NRG 16-52, NRG 16-36, NRG 16-4 and ER 5.-1,  
4 poles with screen

#### Electrode voltage

5 V<sub>SS</sub>

**Response sensitivity** (Electrical conductivity of water at 25 °C)

> 0.5 ... < 1000 µS/cm or > 10 ... < 10 000 µS/cm (switch-selectable)

#### Outputs

2 volt-free change-over contacts, 8 A 250 V AC / 30 V DC cos φ = 1.

De-energizing delay: 3 sec. (MIN or MAX alarm).

Provide inductive loads with RC combinations according to manufacturer's specification to ensure interference suppression.

#### Indicators and adjustors

1 Test button for MIN / MAX alarm,

1 red/green LED for indicating operating mode and MIN / MAX alarm,

1 red/green LED for indicating operating mode and Pump ON

1 green LED for "Power ON",

1 code switch with 4 poles for changing the sensitivity and function

#### Housing

Housing material: base: polycarbonate, black; front: polycarbonate, grey

Conductor size: 1 x 4.0 mm<sup>2</sup> solid per wire or

1 x 2.5 mm<sup>2</sup> per stranded wire with sleeve to DIN 46228 or

2 x 1.4 mm<sup>2</sup> per stranded wire with sleeve to DIN 46228;

Terminal strips can be detached

Fixing of housing: Mounting clip on supporting rail TH 35, EN 60715

#### Electrical safety

Pollution degree 2 for installation in control cabinet with protection IP 54, completely insulated

#### Protection

Housing: IP 40 to EN 60529

Terminal strip: IP 20 to EN 60529

#### Weight

approx. 0.2 kg

## Technical Data - continued -

### NRS 1-54, NRS 1-55 - continued -

#### **Ambient temperature**

when system is switched on: 0 ... 55 °C, during operation: -10 ... 55 °C

#### **Transport temperature**

-20 ... +80 °C (< 100 hours), defrosting time of the de-energized equipment before it can be put into operation: 24 hours.

#### **Storage temperature**

-20 ... +70 °C, defrosting time of the de-energized equipment before it can be put into operation: 24 hours.

#### **Relative humidity**

max. 95 %, no moisture condensation

#### **Approvals:**

TÜV certificate      VdTÜV Bulletin "Water Level 100" (= Water Level 100):  
Requirements made on water level limiting & control equipment.  
Type approval no. TÜV . WR/WB . XX-424 (see name plate)

## Scope of supply

### **NRS 1-54**

1 Level switch NRS 1-54

1 Installation manual

### **NRS 1-55**

1 Level switch NRS 1-55

1 Installation manual



## In control cabinet: Mounting level switch

### Dimensions NRS 1-5..

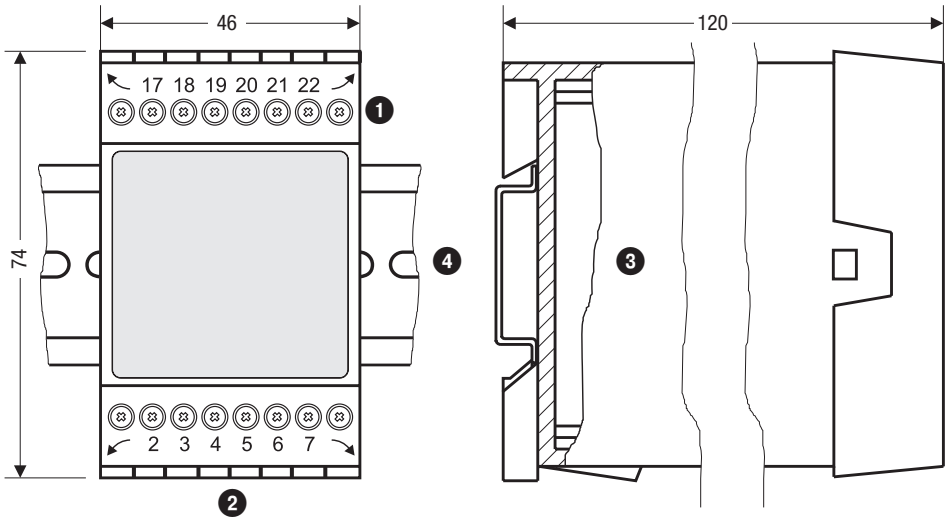

Fig. 1

### Key





- |                        |  |
|------------------------|--|
| 1 Upper terminal strip | 3 Housing                              |
| 2 Lower terminal strip | 4 Supporting rail type TH 35, EN 60715 |

### Installation in control cabinet



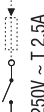

The level switch NRS 1-54, NRS 1-55 is clipped onto the support rail 4 type TH 35, EN 60715 in the control cabinet. **Fig. 1**

Name plate / marking

Name plate (on top)

Type designation	<b>NRS 1 - 54</b>		Betriebsanleitung beachten See installation instructions Voir instructions de montage		GESTRA AG Münchener Str. 77 D-28215 Bremen		Safety note
							
Niveauschalter Level switch Commutateur de niveau		IP 40 (IP20)		Tamb = 55°C (131°F)		Protection	
		250V ~ T 2,5A		External fuse for output contacts		Ambient temperature	
		MAX 3sec		Output contacts			
16	17	18	19	20	21	22	23

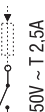
Type designation	<b>NRS 1 - 55</b>		Betriebsanleitung beachten See installation instructions Voir instructions de montage		GESTRA AG Münchener Str. 77 D-28215 Bremen		Safety note
							
Niveauschalter Level switch Commutateur de niveau		IP 40 (IP20)		Tamb = 55°C (131°F)		Protection	
		250V ~ T 2,5A		External fuse for output contacts		Ambient temperature	
		MIN 3sec		Output contacts			
16	17	18	19	20	21	22	23

Name plate (at the bottom)



Fuse, provided on site	M 0,5A	Connection of level electrodes	
Power consumption	2 VA	NRG 1-... ER 5.	
Supply voltage	24 V = +/- 20%	Approvals	
Material number	TÜV.WR/WB.10-424	Disposal note	
Serial number	Mat-Nr.: 392623		
			

Fig. 2

## In control cabinet: Wiring level switch

### Wiring diagram for level switch NRS 1-54, NRS 1-55

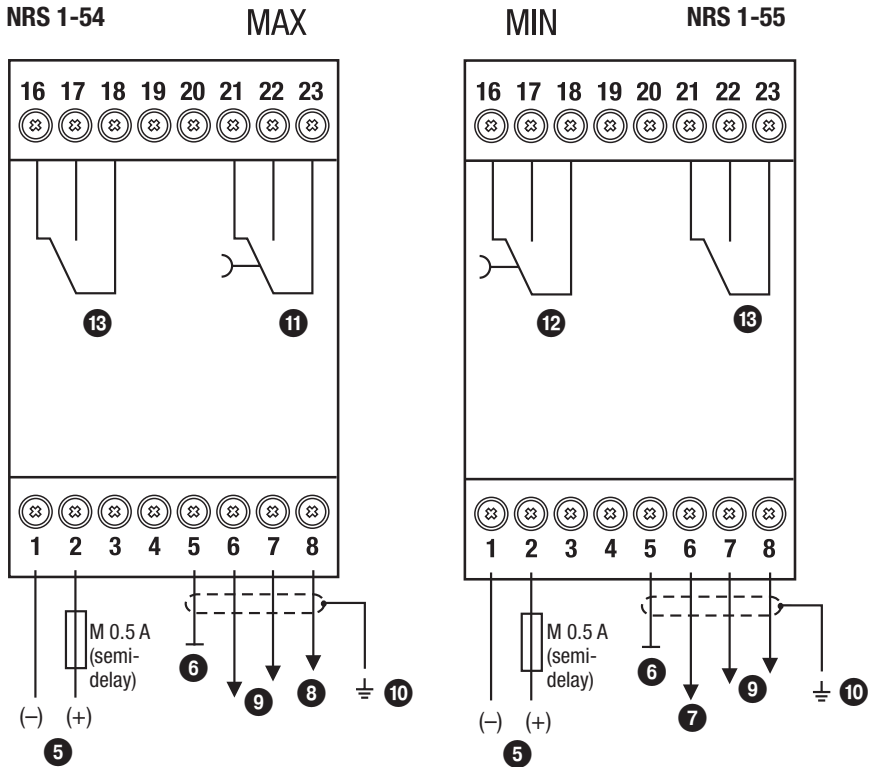

Fig. 3

#### Key

- 5 Connection of supply voltage **24 V DC** with fuse 0.5 A (semi-delay) provided on site
- 6 Reference electrode or vessel used as functional earth
- 7 MIN electrode rod
- 8 MAX electrode rod
- 9 Electrode rods for water level controller
- 10 Central earthing point (CEP) in control cabinet
- 11 MAX output contact
- 12 MIN output contact
- 13 Output contact for water level controller

## In control cabinet: Wiring level switch - continued -

### Connecting supply voltage

The equipment is supplied with 24 V DC and fused with an external semi-delay fuse 0.5 A. Please use a safety power supply unit with safe electrical isolation.

The power supply unit must be electrically isolated from dangerous contact voltages and must meet at least the requirements on double or reinforced isolation according to one of the following standards: DIN EN 50178, DIN EN 61010-1, DIN EN 60730-1 or DIN EN 60950.

### Connecting output contacts

Wire the upper terminal strip ① (terminals 16-18, 21-23) according to the desired switching functions. Provide an external slow-blow fuse 2.5 A for the output contacts.

When switching off inductive loads, voltage spikes are produced that may impair the operation of control and measuring systems. Connected inductive loads must be provided with suppressors such as RC combinations as specified by the manufacturer.

### Connection of level electrode

To connect the level electrode(s) use screened multi-core control cable with a min. conductor size 0.5 mm<sup>2</sup>, e. g. LiYCY 4 x 0.5 mm<sup>2</sup>, max. length: 100 m.

Wire terminal strip in accordance with the wiring diagram. **Fig. 3.**

Connect the screen **only once** to the central earthing point (CEP) in the control cabinet.

Make sure that connecting cables leading to the level electrodes are segregated and run separately from power cables.



#### Attention

- Do not use unused terminals as support point terminals.

### Tools

- For all functions: Screwdriver 0.8 x 4.0 or 0.8 x 4.5, completely insulated according to VDE 0680-1.

# In the plant: Wiring level electrode

## Level switch NRS 1-54: Connecting several level electrodes (fill control)

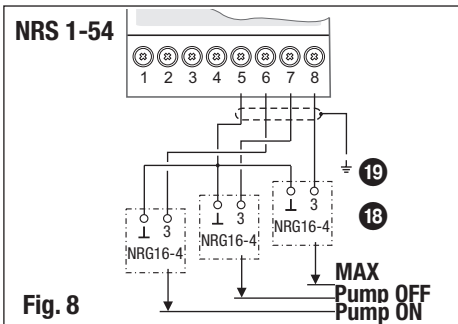
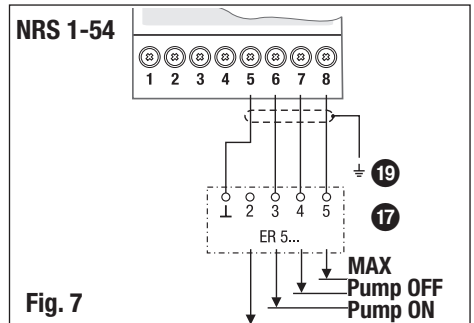
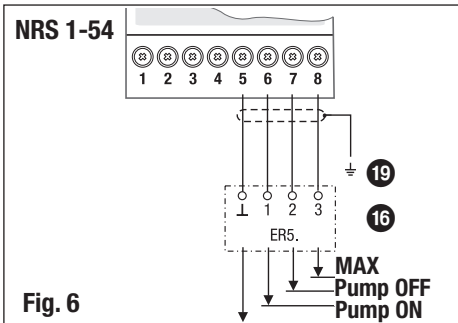
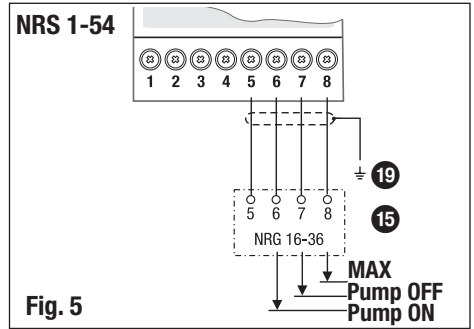
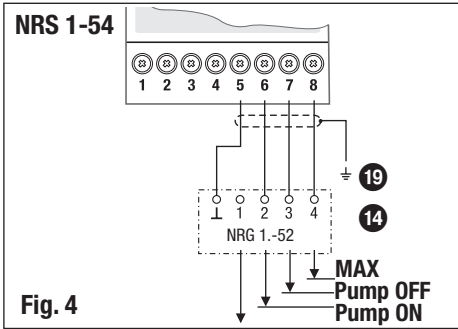

### Key

- 14** Level electrode NRG 10-52, NRG 16-52  
Five pole connector
- 15** Level electrode NRG 16-36
- 16** Level electrode ER 5., 4 pole connector
- 17** Level electrode ER 5..., 6 pole connector
- 18** Level electrode NRG 16-4
- 19** Central earthing point (CEP) in control cabinet

## Level Switch NRS 1-55: Connecting several level electrodes (fill control)

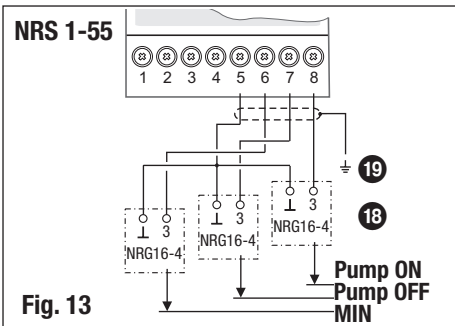
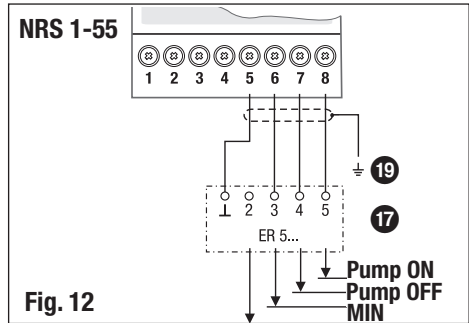
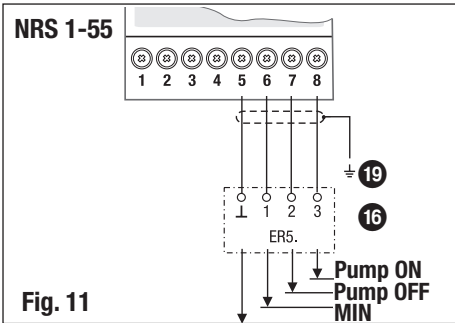
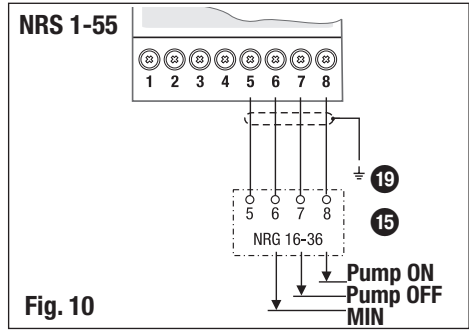
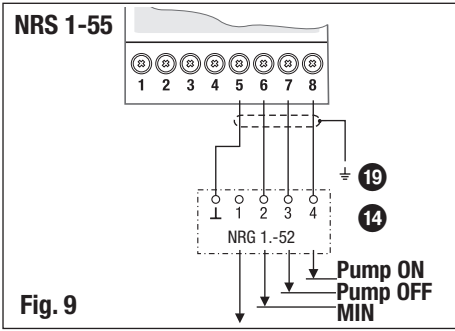

### Key

- 14 Level electrode NRG 10-52, NRG 16-52  
Five pole connector
- 15 Level electrode NRG 16-36
- 16 Level electrode ER 5., 4 pole connector

- 17 Level electrode ER 5..., 6 pole connector
- 18 Level electrode NRG 16-4
- 19 Central earthing point (CEP) in control cabinet

## In the plant: Wiring level electrode - continued -

### Connection of level electrode

The level switch NRS 1-54, NRS 1-55 can be used in combination with the following level electrodes:

Level electrodes				
NRG 10-52, NRG 16-52 Electrode with 4 rods	NRG 16-36 Electrode with 4 rods	NRG 16-4 Electrode with 1 rod	ER 50 Electrode with 4 rods	ER 56 Electrode with 4 rods

To connect the level electrode(s) use screened multi-core control cable with a min. conductor size 0.5 mm<sup>2</sup>, e. g. LiYCY 4 x 0.5 mm<sup>2</sup>, max. length: 100 m.

Wire terminal strip in accordance with the examples **Fig. 4 to 13**.

Check the connection of the screen to the central earthing point (CEP) in the control cabinet.



#### Attention

- Please observe the instructions given in the installation & operating manual for the NRG 10-52, NRG 16-52, NRG 16-36, NRG 16-4 and ER 5.-1!
- Make sure that connecting cables leading to the level electrodes are segregated and run separately from power cables.

### Factory settings

#### Level Switch NRS 1-54

The level switch features the following factory set default values:

- Response sensitivity: 10 µS/cm (at 25 °C)
- Function "Fill control"

#### Level Switch NRS 1-55

The level switch features the following factory set default values:

- Response sensitivity: 10 µS/cm (at 25 °C)
- Function "Discharge control"

## Commissioning procedure



### Danger

The terminal strips of the equipment are live during operation.

This presents the danger of electric shock!

Always **cut off power supply** to the equipment before mounting, removing or connecting the terminal strips!

## Changing response sensitivity and function

The response sensitivity and the function are determined by the code switch **20** setting. To change the code switch setting proceed as follows:

- Cut off supply voltage.
- Remove **lower** terminal strip. **Fig. 14**
  - Insert a screwdriver to the right and left between the terminal strip and the front frame.
  - Unlock terminal strip on the left and right side. For this purpose move screwdriver in direction of the arrow .
  - Remove the terminal strip.

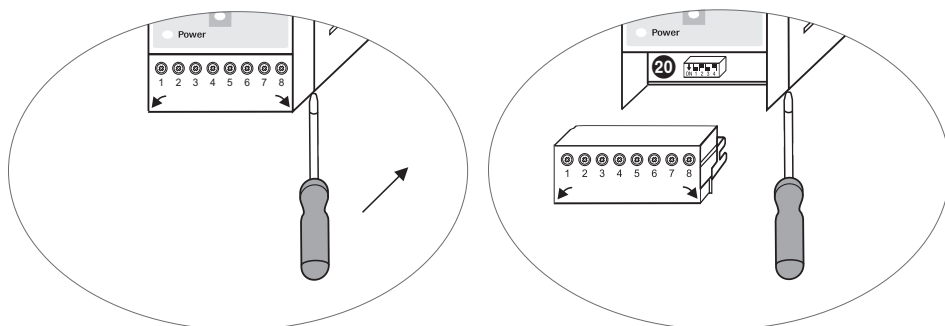

**Fig. 14**

After the new code switch settings have been established as new defaults:

- Re-attach lower terminal strip.
- Apply mains voltage, equipment is re-started.

## Changing response sensitivity

If the electrical conductivity of water is  $< 10 \mu\text{S}/\text{cm}$  at  $25^\circ\text{C}$  set switch S4 of the code switch **20** to ON (= sensitivity of response  $0.5 \mu\text{S}/\text{cm}$ ).



## Changing function

The NRS 1-54 is configured at our works as fill controller and the NRS 1-55 as discharge controller. To change the function set the switches S1 to S3 of code switch 20 to the positions indicated in table Fig. 15.

Code switch 20				
Level switch NRS 1-54	S 1	S 2	S 3	Toggle switch, white
Fill control	ON	ON	OFF	
Discharge control	ON	OFF	ON	
Level switch NRS 1-55				Toggle switch, white
Fill control	OFF	OFF	ON	
Discharge control	OFF	ON	ON	

grey = factory setting

**Fig. 15**

## Level switch NRS 1-54: Checking switchpoint and function

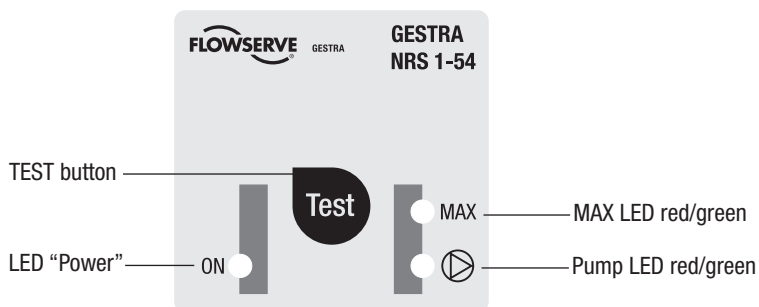

Fig. 16



### Danger

To commission the equipment switch water level control system to manual operation. Make sure that installation is in manual operation mode when you fill or discharge the steam boiler or vessel.

Start		
Activity	Display	Function
Switch on supply voltage.	LED "Power" is illuminated.	
	MAX LED and pump LED are illuminated as a function of the water level	

Checking switchpoint and function (fill control)		
Lower water level until it is below "Pump ON" level. Electrode rod "Pump ON" is exposed.	Pump LED illuminated green.	Pump output contact 17/18 closed, 16/18 open.
Fill vessel until water level "Pump OFF" is exceeded. Electrode rod "Pump OFF" is submerged.	Pump LED is not illuminated.	Pump output contact 16/18 closed, 17/18 open.

Checking switchpoint and function (discharge control)		
Fill vessel until water level "Pump ON" is exceeded. Electrode rod "Pump ON" is submerged.	Pump LED illuminated green.	Pump output contact 17/18 closed, 16/18 open.
Lower water level until it is below "Pump OFF" level. Electrode rod "Pump OFF" is exposed.	Pump LED is not illuminated.	Pump output contact 16/18 closed, 17/18 open.

## Level switch NRS 1-54: Checking switchpoint and function - continued -

Checking switchpoint and function (MAX alarm)		
Fill vessel until MAX level is exceeded. MAX electrode rod enters the water.	MAX LED flashes red.	De-energizing delay is running.
	MAX LED illuminated red	Time delay has elapsed. MAX output contact 21/23 closed, 22/23 open.

Possible installation faults		
Status and indication	Error	Remedy
Water level below MAX switchpoint, MAX LED illuminated red.	Electrode rods are too long.	Cut electrode rods to the length dictated by the switchpoints.
	If installed inside the boiler: Upper vent hole in protection tube does not exist or is obstructed.	Check installation of level electrode. Make sure that the level in the protection tube corresponds to the actual water level.
Switchpoint MAX water level reached, MAX LED illuminated green.	Electrode rods are too short.	Replace level electrode and cut electrode rods to the length dictated by the switchpoints.
	The earth connection to the vessel is interrupted.	Clean seating surfaces and screw in level electrode with metallic joint ring. Do not insulate the electrode with hemp or PTFE tape!
	Electrical conductivity of the boiler water too low.	Change response sensitivity to 0.5 $\mu\text{S}/\text{cm}$
	Upper vent hole flooded.	Check installation of level electrode. Make sure that the level in the protection tube corresponds to the actual water level.
Water level between MAX and pump ON / OFF. MAX LED and pump LED are flashing simultaneously.	Electrical connections of electrode rods are mixed up.	Check and change the electrical connection of the level electrode.

## Level switch NRS 1-55: Checking switchpoint and function

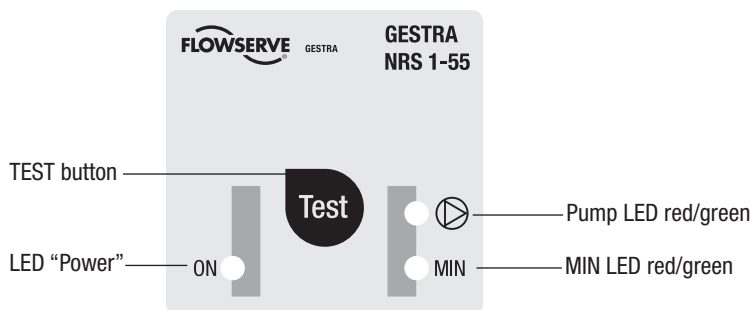

Fig. 17



### Danger

To commission the equipment switch water level control system to manual operation. Make sure that installation is in manual operation mode when you fill or discharge the steam boiler or vessel.

Start		
Activity	Display	Function
Switch on supply voltage.	LED "Power" is illuminated.	
	MIN LED and pump LED are illuminated as a function of the water level	

Checking switchpoint and function (fill control)		
Lower water level until it is below "Pump ON" level. Electrode rod "Pump ON" is exposed.	Pump LED illuminated green.	Pump output contact 22/23 closed, 21/23 open.
Fill vessel until water level "Pump OFF" is exceeded. Electrode rod "Pump OFF" is submerged.	Pump LED is not illuminated.	Pump output contact 21/23 closed, 22/23 open.

Checking switchpoint and function (discharge control)		
Fill vessel until water level "Pump ON" is exceeded. Electrode rod "Pump ON" is submerged.	Pump LED illuminated green.	Pump output contact 22/23 closed, 21/23 open.
Lower water level until it is below "Pump OFF" level. Electrode rod "Pump OFF" is exposed.	Pump LED is not illuminated.	Pump output contact 21/23 closed, 22/23 open.

## Level switch NRS 1-55: Checking switchpoint and function - continued -

Checking switchpoint and function (MIN alarm)		
Lower water level until it is below MIN level. MIN electrode rod is exposed.	MIN LED flashes red.	De-energizing delay is running.
	MIN LED illuminated red	Time delay has elapsed. MIN output contact 16/18 closed, 17/18 open.

Possible installation faults		
Status and indication	Error	Remedy
Water level below MIN switchpoint, MIN LED illuminated green.	Electrode rods are too long.	Cut electrode rods to the length dictated by the switchpoints.
	If installed inside the boiler: Upper vent hole in protection tube does not exist or is obstructed.	Check installation of level electrode. Make sure that the level in the protection tube corresponds to the actual water level.
Switchpoint MIN water level exceeded, MIN LED illuminated red.	Electrode rods are too short.	Replace level electrode and cut electrode rods to the length dictated by the switchpoints.
	The earth connection to the vessel is interrupted.	Clean seating surfaces and screw in level electrode with metallic joint ring. Do not insulate the electrode with hemp or PTFE tape!
	Electrical conductivity of the boiler water too low.	Change response sensitivity to 0.5 $\mu\text{S}/\text{cm}$
	Upper vent hole flooded.	Check installation of level electrode. Make sure that the level in the protection tube corresponds to the actual water level.
Water level between MIN and pump ON / OFF. MIN LED and pump LED are flashing simultaneously.	Electrical connections of electrode rods are mixed up.	Check and change the electrical connection of the level electrode.

## Operation, Alarm and Test

### Level switch NRS 1-54: Indicators and adjustors

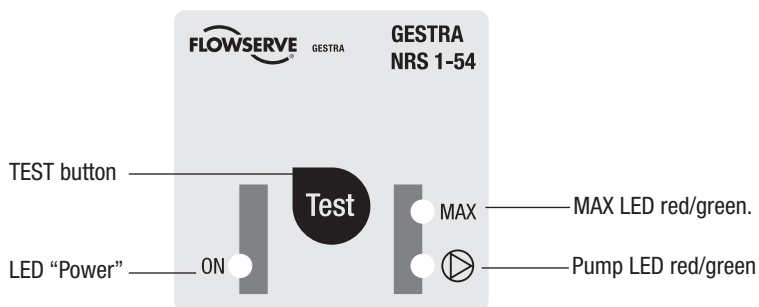
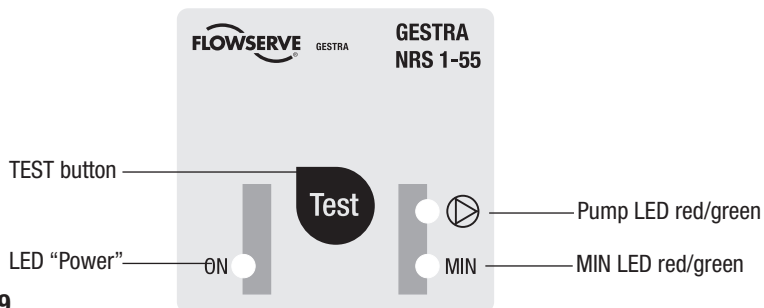

Fig. 18

Fill control		
Activity	Display	Function
Level below switchpoint "Pump ON"	Pump LED illuminated green.	Pump output contact 17/18 closed, 16/18 open.
Level above switchpoint "Pump OFF"	Pump LED is not illuminated.	Pump output contact 16/18 closed, 17/18 open.
Discharge control		
Activity	Display	Function
Switchpoint "Water level - pump ON" exceeded	Pump LED illuminated green.	Pump output contact 17/18 closed, 16/18 open.
Level below switchpoint "Water level - pump OFF"	Pump LED is not illuminated.	Pump output contact 16/18 closed, 17/18 open.
MAX alarm		
Activity	Display	Function
Water level above MAX switchpoint.	MAX LED flashes red.	De-energizing delay is running.
	MAX LED illuminated red	Time delay has elapsed. MAX output contact 21/23 closed, 22/23 open.
Test MIN alarm		
Activity	Display	Function
<b>During operation:</b> Level below switchpoint MAX water level, MAX LED illuminated green. Press and hold down button "Test".	MAX LED flashes red.	De-energizing delay is running.
	MAX LED is illuminated red for 3 sec.	MAX output contact 21/23 closed, 22/23 open.
The test is finished. Release button "Test". Equipment returns to operating mode.	Note: If you continue to hold down the Test button, a new test is started. You can abort the test any moment by releasing the Test button.	

## Level switch NRS 1-55: Indicators and adjustors



**Fig. 19**

Fill control		
Activity	Display	Function
Level below switchpoint "Pump ON"	Pump LED illuminated green.	Pump output contact 22/23 closed, 21/23 open.
Level above switchpoint "Pump OFF"	Pump LED is not illuminated.	Pump output contact 21/23 closed, 22/23 open.

Discharge control		
Switchpoint "Water level - pump ON" exceeded	Pump LED illuminated green.	Pump output contact 22/23 closed, 21/23 open.
Level below switchpoint "Water level - pump OFF"	Pump LED is not illuminated.	Pump output contact 21/23 closed, 22/23 open.

MIN alarm		
Water level below MIN switchpoint.	MIN LED flashes red.	De-energizing delay is running.
	MIN LED illuminated red	Time delay has elapsed. MIN output contact 16/18 closed, 17/18 open.

Test MIN alarm		
<b>During operation:</b> Switchpoint "MIN water level" exceeded, MIN LED illuminated green. Press and hold down button "Test".	MIN LED flashes red.	De-energizing delay is running.
	MIN LED is illuminated red for 3 sec.	MIN output contact 16/18 closed, 17/18 open.
The test is finished. Release button "Test". Equipment returns to operating mode.	Note: If you continue to hold down the Test button, a new test is started. You can abort the test any moment by releasing the Test button.	

## Further Notes

### Action against high frequency interference

High-frequency interference can be caused by out-of-phase switching operations. Should sporadic failures or malfunctions occur take the following remedial actions in order to suppress interference:

- Provide inductive loads with RC combinations according to manufacturer's specification to ensure interference suppression.
- Increase the distance to sources of interference.
- Check the connection of the screen to the central earthing point (CEP) in the control cabinet.
- HF interference suppression by means of hinged-shell ferrite rings.
- Make sure that connecting cables leading to the level electrodes are segregated and run separately from power cables.

### Decommissioning / replacing the equipment

- Switch off supply voltage and **cut off power supply** to the equipment.
- Remove the lower and upper terminal strips. **Fig. 14.**
- Release the white fixing slide at the bottom of the equipment and take the equipment off the supporting rail.

### Disposal

For the disposal of the equipment observe the pertinent legal regulations concerning waste disposal.

If faults occur that are not listed above or cannot be corrected, please contact our service centre or authorized agency in your country.











GESTRA

Agencies all over the world:

[www.gestra.de](http://www.gestra.de)

#### Great Britain

##### Flowserve GB Limited

Abex Road  
Newbury, Berkshire RG14 5EY  
Tel. 0044 16 35 / 46 99 90  
Fax 0044 16 35 / 3 60 34  
E-Mail [gestraukinfo@flowserve.com](mailto:gestraukinfo@flowserve.com)  
Web [www.flowserve.com](http://www.flowserve.com)

#### Singapore

##### Flowserve Pte. Ltd.

12 Tuas Avenue 20  
Singapore 63882  
Tel. 0065 / 68 79 89 00  
Fax 0065 / 68 62 49 40  
E-Mail [fcd\\_gestra\\_singapore@flowserve.com](mailto:fcd_gestra_singapore@flowserve.com)  
Web [www.gestra.com](http://www.gestra.com)

#### South Africa

##### Flowserve SA (Pty) Ltd.

Unit No. 1  
Director Road  
Spartan Extension 2  
Kempton Park 1613  
Tel. 0027 11 / 9 23 73 00  
Fax 0027 11 / 9 74 64 20  
E-Mail [tvniekerk@flowserve.com](mailto:tvniekerk@flowserve.com)  
Web [www.flowserve.com](http://www.flowserve.com)

#### USA

##### Flowserve GESTRA U.S.

2341 Ampere Drive  
Louisville, KY 40299  
Tel. 001 502 / 267-22 05  
Fax 001 502 / 266-53 97  
E-Mail [fcd-gestra-usa@flowserve.com](mailto:fcd-gestra-usa@flowserve.com)

## GESTRA AG

P. O. Box 10 54 60, D-28054 Bremen  
Münchener Str. 77, D-28215 Bremen  
Tel. 0049 (0) 421 35 03 - 0  
Fax 0049 (0) 421 35 03 - 393  
E-Mail [gestra.ag@flowserve.com](mailto:gestra.ag@flowserve.com)  
Web [www.gestra.de](http://www.gestra.de)

