



FLOWSERVE[®]



GESTRA

GESTRA Steam Systems

NRS 1-50

For **TWO** Electrodes

EN

English

Installation Instructions 818953-01

Level Switch

NRS 1-50

Contents

Page

Application

| | |
|--------------------------------------|---|
| Usage for the intended purpose | 4 |
| Function | 4 |

Directives and Standards

| | |
|--|---|
| Pressure Equipment Directive (PED) 97/23/EC | 5 |
| Functional Safety acc. to IEC 61508 5 | 5 |
| VdTÜV Bulletin "Wasserstand 100" (= Water Level 100) | 5 |
| Approvals for Marine Applications | 5 |
| LV (Low Voltage) Directive and EMC (Electromagnetic Compatibility) | 5 |
| ATEX (Atmosphère Explosible) | 5 |

Functional Safety acc. to IEC 61508

| | |
|--|---|
| Safety characteristics of the subsystem NRG 1...-50 / NRS 1-50 | 6 |
| Terms and abbreviations | 6 |
| Determination of the Safety Integrity Level (SIL) for safety-related systems | 7 |

Technical Data

| | |
|----------------------------|-------|
| NRS 1-50 | 8 – 9 |
| Name plate / marking | 10 |

Dimensions and Functional Ele-

| | |
|----------------|----|
| NRS 1-50 | 11 |
|----------------|----|

Important Notes

| | |
|-----------------------|----|
| Safety note | 12 |
| Scope of supply | 12 |

Installation

| | |
|--------------------------------------|----|
| Mounting level switch NRS 1-50 | 13 |
|--------------------------------------|----|

Contents – continued –

Page

Electrical Connection

| | |
|---|----|
| Mains supply | 13 |
| Connection of level electrode | 13 |
| Connection of safety circuit..... | 13 |
| Connection of logic unit (standby input)..... | 13 |
| Connection for signal output | 13 |
| Tools..... | 14 |
| Wiring diagram for level switch NRS 1-50..... | 15 |
| Schematic representations of arrangements | 16 |
| Explanatory notes to schematic representations..... | 17 |

Basic Settings

| | |
|-----------------------|----|
| Factory setting | 18 |
|-----------------------|----|

Commissioning Procedure

| | |
|---|----|
| Changing configuration | 18 |
| Checking switchpoint and function | 19 |

Operation, Alarm and Test

| | |
|-------------------------------|----|
| Indicators and adjustors..... | 20 |
|-------------------------------|----|

Troubleshooting

| | |
|---------------------------------------|---------|
| Indication, diagnosis and remedy..... | 20 – 21 |
|---------------------------------------|---------|

Checking level electrode

| | |
|---|----|
| Measuring voltage across level electrode..... | 22 |
|---|----|

Emergency operation

| | |
|---|----|
| Emergency operation for water level limiter | 23 |
|---|----|

Further Notes

| | |
|---|----|
| Action against high frequency interference | 24 |
| Interlock and interlock deactivation..... | 24 |
| Checking the switchpoints | 24 |
| Decommissioning / replacing level switch..... | 24 |
| Disposal..... | 24 |
| Note on the Declaration of Conformity / Declaration by the Manufacturer CE | 24 |

Application

Usage for the intended purpose

The level switch NRS 1-50 is used in conjunction with level electrodes NRG 1...-.. to limit the water level in steam boilers and (pressurised) hot-water plants.

Water level limiters switch off the heating when the water level falls below the set minimum level (low water).

Depending on the specified directives or standards, the level switch NRS 1-50 is intended to be used in combination with the following level electrodes:

| Level electrode NRG 1...-.. | | | | | |
|---|------------------------|------------------------|------------------------|--------------------------|-----------|
| PED Pressure Equipment Directive 97/23/EC + Functional Safety IEC 61508 SIL 3 | NRG 16-50 | NRG 17-50 | NRG 19-50 | NRG 111-50 | NRG 16-36 |
| VdTÜV Bulletin "Wasserstand 100" (= Water Level 100) | NRG 16-50 NRG 16-11 | NRG 17-50 NRG 17-11 | NRG 19-50 NRG 19-11 | NRG 111-50 NRG 111-11 | NRG 16-36 |
| Marine applications GL/LR Directives | NRG 16-50S | NRG 16-11S | NRG 16-38S | NRG 16-39S | |

Function

The level switch NRS 1-50 is designed for different electrical conductivities of the boiler water and for connecting one or two level electrodes.

See section **Schematic representations of arrangements** on page 16.

When the water level falls below the low level the level electrodes are exposed and a low level alarm is triggered in the level switch. This switchpoint is determined by the length of the electrode rod (level electrode NRG 1...-50, NRG 1...-11, NRG 16-36).

After the de-energizing delay has elapsed, the two output contacts of the level switch will open the safety circuit for the heating. The switching-off of the heating is interlocked in the external safety circuit and can only be deactivated when the level electrode enters the water again.

An alarm will also be raised if a malfunction occurs in the level electrode and/or the electrical connection.

If the level electrode is installed in an isolatable level pot outside the boiler, make sure that the connecting lines are rinsed regularly. During the rinsing process the water level cannot be measured in the level pot for 5 minutes. The level switch therefore bypasses the level electrode and monitors the rinsing and bypass time (standby input, controlled by the logic unit SRL 6-50).

If the connecting lines for steam ≥ 40 mm and water ≥ 100 mm, the installation is considered to be internal. In this case the rinsing processes do not have to be monitored.

An automatic self-testing routine monitors the safety functions in the level switch and the level electrodes. In the event of a malfunction the safety circuit opens instantaneously and switches the heating off.

Alarm and error messages are indicated by LEDs and a signal output for each level electrode is energized without delay.

An alarm can be simulated by pressing the test button.

Directives and Standards

Pressure Equipment Directive (PED) 97/23/EC

Water level limiters are safety accessories as defined in the Pressure Equipment Directive (PED). The level switch NRS 1-50 in conjunction with level electrode NRG 1...-50 and NRG 16-36 is EC type approved according to EN 12952/EN 12953. These Directives state, among other things, the requirements made on limiting systems and equipment for steam boiler plants and (pressurised) hot-water installations.

Functional Safety acc. to IEC 61508

The level switch NRS 1-50 is certified acc. to IEC 61508 only if used in combination with level electrode NRG 1...-50 / NRG 16-36. This standard describes the functional safety of safety-related electrical/electronic/programmable electronic systems.

The equipment combination NRG 1...-50 or NRG 16-36 + NRS 1-50 corresponds to a type B subsystem with Safety Integrity Level (SIL) 3.

VdTÜV Bulletin "Wasserstand 100" (= Water Level 100)

The level switch NRS 1-50 in conjunction with the level electrodes NRG 1...-50, NRG 1...-11 and NRG 16-36 is type approved according to the VdTÜV Bulletin "Water Level 100".

The VdTÜV Bulletin "Wasserstand (=Water Level) 100" specifies the requirements made on water level control and limiting equipment for boilers.

Approvals for Marine Applications

The level switch NRS 1-50 in conjunction with level electrodes NRG 16-50S/NRG 16-11S/NRG 16-38S and NRG 16-39S is approved for marine applications.

We can present approvals issued by Germanischer Lloyd and Lloyd's Register.

LV (Low Voltage) Directive and EMC (Electromagnetic Compatibility)

The level switch NRS 1-50 meets the requirements of the Low Voltage Directive 2006/95/EC and the EMC Directive 2004/108/EC.

ATEX (Atmosphère Explosible)

According to the European Directive 94/9/EC the level switch NRS 1-50 must **not** be used in potentially explosive areas.



Note

The level electrodes NRG 1...-50, NRG 1...-11 and NRG 16-36 are simple items of electrical equipment as specified in EN 60079-11 section 5.7. According to the European Directive 94/9/EC the equipment must be equipped with approved Zener barriers if used in potentially explosive areas. Applicable in Ex-zones 1, 2 (1999/92/EC).

The equipment does not bear an Ex marking. The suitability of the Zener barriers is certified in a separate document.

Note that the requirements of the IEC 61508 are not met if the NRG 1...-50, NRG 1...-11 and NRG 16-36 + Zener barriers + NRS 1-50 are interconnected!

Functional Safety acc. to IEC 61508

Safety characteristics of the subsystem NRG 1...-50 / NRS 1-50

The level switch NRS 1-50 is certified acc. to IEC 61508 if used in combination with level electrode NRG 1...-50 / NRG 16-36 .

The combination NRG 1...-50 / NRG 16-36 / NRS 1-50 corresponds to a type B subsystem with Safety Integrity Level (SIL) 3. Type B means that the behaviour under fault conditions of the used components cannot be completely determined. The functional safety of the equipment combination refers to the detection and evaluation of the water level and, as a consequence, the contact position of the output relays.

The design of the equipment combination NRG 1...-50 / NRG 16-36 / NRS 1-50 corresponds to the architecture 1oo2 D.

This architecture consists of two channels that detect and diagnose faults in each other. If a fault is detected, the equipment combination NRG 1...-50 / NRG 16-36 / NRS 1-50 will go to the safe state, which means that the contacts of both output relays will open the safety circuit.

| Safety characteristics | SIL | Architecture | Lifetime (a) | Proof Test Interval (a) |
|--|---------|-------------------------|-------------------------|----------------------------|
| General | 3 | 1oo2 D | 20 | 20 |
| | SFF | PFD _{av} | PFH _{av} | λ _{DU} |
| Level switch NRS 1-50 alone | 98.54 % | 1.18 x 10 ⁻⁴ | 3.73 x 10 ⁻⁸ | 7.33 x 10 ⁻⁸ /h |
| Level switch NRS 1-50 in conjunction with one level electrode NRG 1...-50, NRG 16-36 | 98.17 % | 1.69 x 10 ⁻⁴ | 4.54 x 10 ⁻⁸ | 9.33 x 10 ⁻⁸ /h |
| Level switch NRS 1-50 in conjunction with two level electrodes NRG 1...-50 | 97.80 % | 1.17 x 10 ⁻⁴ | 3.76 x 10 ⁻⁸ | 7.38 x 10 ⁻⁸ /h |

Fig. 1

Terms and abbreviations

| Terms Abbreviations | Description |
|---|--|
| Safety Integrity Level SIL | Classification of the Safety Integrity Level acc. to IEC 61508 |
| Lifetime (a) | Functional safety: Lifetime in years |
| Safe Failure Fraction SFF | Percentage of failures without the potential to put the safety-related system into a dangerous state |
| Probability Failure per Demand (Low Demand) PFD _{av} | Average probability of failure on demand for low demand mode (once a year) |
| Probability Failure per Hour PFH _{av} | Probability of failure per hour |
| λ _{DU} | Failure rate for all dangerous undetected failures (per hour) of a channel of a subsystem |

Fig. 2

Determination of the Safety Integrity Level (SIL) for safety-related systems

Level electrode, level switch and actuators (auxiliary contactor in safety circuit) are subsystems and together constitute a safety-related system that executes a safety function.

The specification of the safety-related characteristics **Fig. 1** refers to the level electrode and the level switch including the output contacts. The actuator (e. g. an auxiliary contactor in the safety circuit) is installation specific and, according to IEC 61508, must be considered separately for the whole safety-related system.

Table **Fig. 3** shows the dependence of the Safety Integrity Level (SIL) on the average probability of failure on demand of a safety function for the **whole** safety-related system (PFD_{sys}). The “Low demand mode” is here considered for a water level limiter, which means that the frequency of demands for operation of the safety-related system is no greater than one per year.

| Low demand mode PFD_{sys} | Safety Integrity Level (SIL) |
|--------------------------------|------------------------------|
| $\geq 10^{-5} \dots < 10^{-4}$ | 4 |
| $\geq 10^{-4} \dots < 10^{-3}$ | 3 |
| $\geq 10^{-3} \dots < 10^{-2}$ | 2 |
| $\geq 10^{-2} \dots < 10^{-1}$ | 1 |

Fig. 3

The table in **Fig. 4** indicates the attainable Safety Integrity Level (SIL) as a function of the Safe Failure Fraction (SFF) and the Hardware Fault Tolerance (HFT) for safety-related systems.

| Hardware Fault Tolerance (HFT) for type B | | | Safe Failure Fraction (SFF) |
|---|-------|-------|-----------------------------|
| 0 | 1 | 2 | |
| | SIL 1 | SIL 2 | < 60 % |
| SIL 1 | SIL 2 | SIL 3 | 60 % - < 90 % |
| SIL 2 | SIL 3 | SIL 4 | 90 % - < 99 % |
| SIL 3 | SIL 4 | SIL 4 | ≥ 99 % |

Fig. 4

Technical Data

NRS 1-50

Supply:

Mains voltage

24 VDC +/- 20 %, 0.3 A or 100-240 VAC + 10/- 15 %, 47-63 Hz, 0.2 A

External fuse

0.5 A (semi-delay)

Power consumption

7 VA

Response sensitivity (Electrical conductivity of water at 25 °C)

> 0.5 ... < 1000 μ S/cm or

> 10 ... < 1000 μ S/cm

Inputs:

Electrical connection of level electrode

2 inputs for level electrode NRG 1...-50, NRG 1...-11, NRG 16-36, 4 poles, with screen, Sensitivity 0.5 μ S/cm or 10 μ S/cm (at 25 °C).

Stand-by input

2 volt-free inputs, 24 V DC, for monitoring the purging and bypass time.

Max. bypass time: 5 minutes.

Outputs:

Safety circuit

2 volt-free make contacts, 24 V DC - 250 V AC, max. 6 A (resistive/inductive),

Contact material AgNi.

Delay of response: 3 seconds, 15 sec. for marine applications.

Provide inductive loads with RC combinations according to manufacturer's specification to ensure interference suppression.

Signal output

2 volt-free outputs for instantaneous external signalling, 24 – 230 V AC/DC, max. 100 mA.

Indicators and adjustors

2 buttons for test and diagnosis,

2 red/green LEDs for indicating the operating mode and alarm.

3 red LEDs for diagnosis,

2 two-pole code switches for setting the number of electrodes.

Housing

Housing material: base: polycarbonate, black; front: polycarbonate, grey.

Cross section of connection: 1 x 4.0 mm² solid per wire or

1 x 2.5 mm² per stranded wire with sleeve to DIN 46228 or

2 x 1.4 mm² per stranded wire with sleeve to DIN 46228; terminal strips can be detached

Fixing of housing: Mounting clip on supporting rail TH 35, EN 60715

Electrical safety

Degree of contamination: 2, overvoltage category III to EN 61010-01.

Protection

Housing: IP 40 to EN 60529

Terminal strip: IP 20 to EN 60529

Weight

approx. 0.5 kg

NRS 1-50 – continued –

Further conditions:

Ambient temperature

when system is switched on: 0 ° ... 55 °C

during operation: –10 ... 55 °C

Transport temperature

–20 ... +80 °C (<100 hours), defrosting time of the de-energized equipment before it can be put into operation: 24 hours.

Storage temperature

–20 ... +70 °C, defrosting time of the de-energized equipment before it can be put into operation: 24 hours.

Relative humidity

max. 95 %, no moisture condensation

Site altitude

max. 2000 m

Approvals:

| | |
|----------------------------|--|
| EC Prototype approval | PED Pressure Equipment Directive 97/23/EC EN 12952-11, EN 12953-09: Requirements made on limiting equipment for boilers. |
| Functional safety SIL 3 | IEC 61508 Functional safety of safety-related electrical/ electronic/programmable electronic systems |
| TÜV type approval | VdTÜV Bulletin “Wasserstand 100” (= Water Level 100): Requirements made on water level limiting & control equipment. Type approval no. TÜV · SWB · XX -422 (see name plate) |
| Marine applications | Regulations of Germanischer Lloyd, Lloyd's Register |

Name plate / marking

| | | | | | | |
|----------------|---|---|--|------|-------------------|---|
| Safety note | | Betriebsanleitung beachten See installation instructions Voir instructions de montage | Niveauschalter Level switch Commutateur de niveau | | NRS 1 - 50 | Type designation |
| | | | 24V = + / - 20% | 7 VA | IP 40 (IP20) | |
| Wiring diagram | | | Tamb = 55°C (131°F) | | 10 µS/cm | Wire link, provided on site Safety circuit Fuse, provided on site |
| | Funktionale Sicherheit Functional safety Sécurité fonctionnelle IEC 61508 SIL 3 | | Wasserstandbegrenzer Water level limiter Limiteur de niveau d'eau | | | Approvals |
| Manufacturer | GESTRA AG Münchener Str. 77 D-28215 Bremen | | TÜV . SWB . 09-422 | | 0525 | Disposal note |
| | | | | | | |

Fig. 5

Serial number

Dimensions and Functional Elements

NRS 1-50

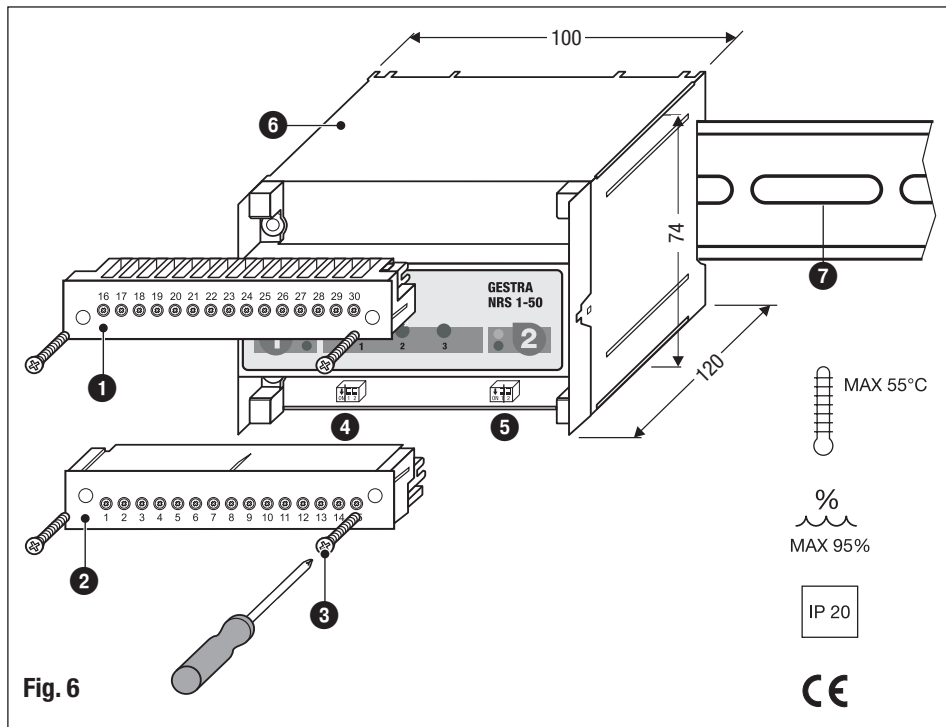

The code switches are accessible after removing the lower terminal strip. The terminal strips can be unplugged after undoing the right and the left fixing screws.

Key

- 1 Upper terminal strip
- 2 Lower terminal strip
- 3 Fixing screws (cross recess head screws M3)
- 4 Code switch for switching on/off level electrode 1 / 2
- 5 Code switch for switching on/off level electrode 1 / 2
- 6 Enclosure
- 7 Supporting rail type TH 35, EN 60715

Important Notes

Safety note

Water level limiters are safety devices and must only be installed, wired and commissioned by qualified and competent staff.

Retrofitting and maintenance work must only be performed by qualified staff who – through adequate training – have achieved a recognised level of competence.



Danger

The terminal strips of the equipment are live during operation.

This presents the danger of electric shock!

Always **cut off power supply** to the equipment before mounting, removing or connecting the terminal strips!



Attention

The name plate specifies the technical features of the equipment. Note that any piece of equipment without its specific name plate must neither be commissioned nor operated.

Scope of supply

NRS 1-50

1 Level switch NRS 1-50

1 Installation manual

Installation

Mounting level switch NRS 1-50

The level switch NRS 1-50 is clipped onto the support rail  type TH 35, EN 60715 in the control cabinet. **Fig. 6**

Electrical Connection

Mains supply

Provide the level switch NRS 1-50 with an external semi-delay fuse 0.5 A.

Connection of level electrode

To connect the level electrode(s) use screened multi-core control cable with a min. conductor size 0.5 mm², e.g. LiYCY 4 x 0.5 mm².

Max. length 100 m with an electrical conductivity of the boiler water > 10 µS/cm at 25 °C.

Max. length 30 m with an electrical conductivity of the boiler water < 10 µS/cm at 25 °C.

Wire terminal strip in accordance with the wiring diagram. **Fig. 5.**

Connect screens **only** to terminals 5 and 13.

Connection of safety circuit

Connect the safety circuit for the heating to terminals 23, 24 and 26, 27. Wenn used as water level limiter according to TRD, EN 12952 / EN 12953 connect the output contacts of the two monitoring channels by adding a wire link between the terminals 24 and 26.

Provide the output contacts with a 2 A or 1 A (for 72 hours operation acc. to TRD 604) slow-blow fuse.



Note

- In the event of an alarm the level switch NRS 1-50 does not interlock automatically. If a lock function is required by the installation it must be provided in the follow-up circuitry (safety circuit). The circuitry must meet the requirements of the EN 50156.

Connection of logic unit (standby input)

For connecting the level switch with the logic unit use a control cable, e. g. 2 x 0.5 mm². The control voltage must not exceed 36 V DC.

Connection for signal output

A signal output for the connection of further external signalling equipment is allocated to each monitoring channel in the level switch, max. load 100 mA. For connecting the level switch with the logic unit use a control cable, 2 x 0.5 mm². In the event of an alarm or error message the signal outputs (terminals 20, 21 and 29, 30) open instantaneously.



Danger

- For the supply of the level switch NRS 1-50 with 24 V DC use a safety extra-low voltage (SELV) power supply unit that must be electrically isolated from dangerous contact voltages and must meet at least the requirements on double or reinforced isolation acc. to DIN EN 50178 or DIN EN 61010-1 or DIN EN 60730-1 or DIN EN 60950 (safe isolation).
- Any item of equipment that you want to connect to terminals 6, 7, 14, 15 (standby input 1 / 2) must be certified to have at least double or reinforced isolation according to DIN EN 50178 or DIN EN 61010-1 or DIN EN 60730-1 or DIN EN 60950 (safe isolation) between the standby inputs and the live parts of the installation that are not supplied with safety extra-low voltage (SELV).



Attention

- Provide the level switch NRS 1-50 with an external semi-delay fuse 0.5 A.
- Connect screens of electrode wires only to terminals 5 and 13.
- To protect the switching contacts provide the safety circuit with a slow-blow fuse 2 A or 1.0 A (for 72 hrs. operation acc. to TRD 604).
- When switching off inductive loads, voltage spikes are produced that may impair the operation of control and measuring systems. Connected inductive loads must be provided with suppressors such as RC combinations as specified by the manufacturer.
- When used as water level limiter according to TRD, EN 12952 / EN 12953 connect terminals 24 and 26 by adding a wire link.
- Install connecting lines to level electrodes and logic unit separated from power cables.
- Do not use unused terminals as support point terminals.

Tools

- Screwdriver for slotted screws, size 3.5 x 100 mm, completely insulated according to VDE 0680-1.

Wiring diagram for level switch NRS 1-50

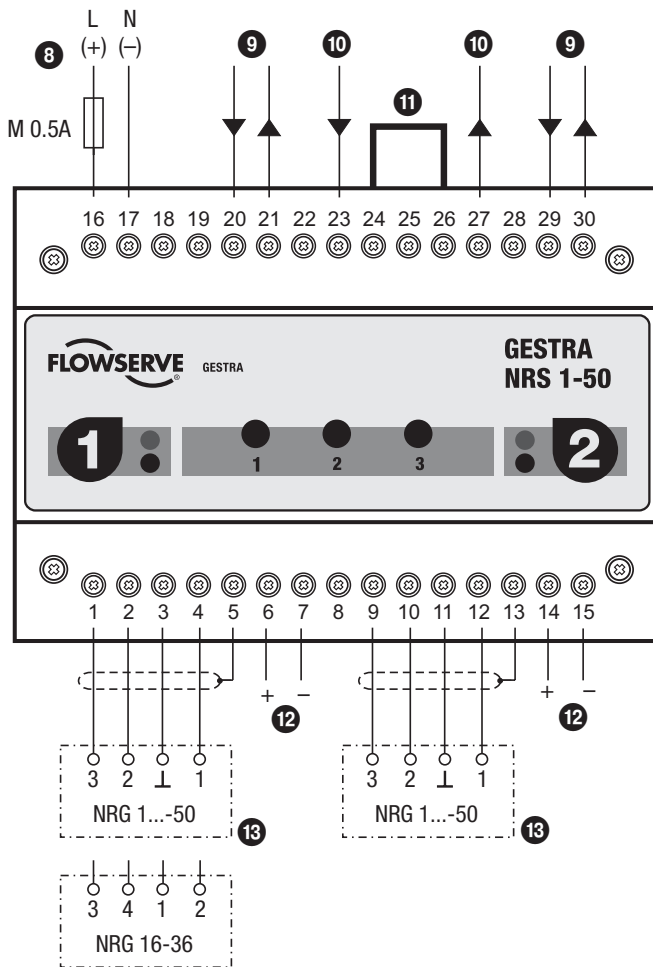
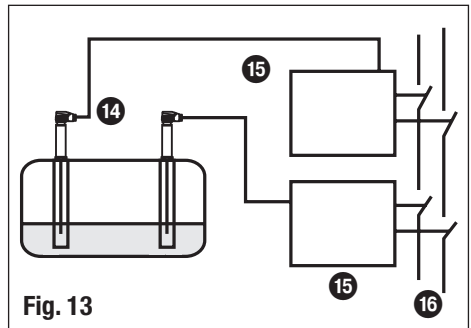
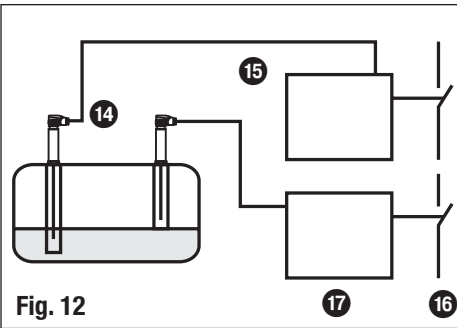
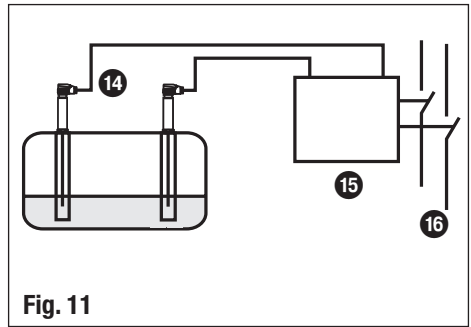
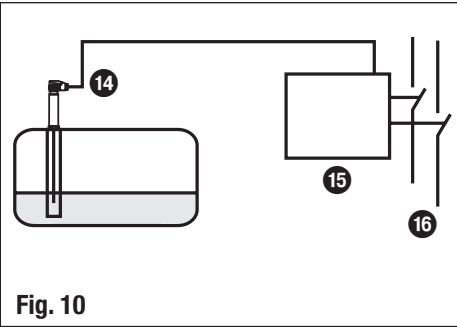
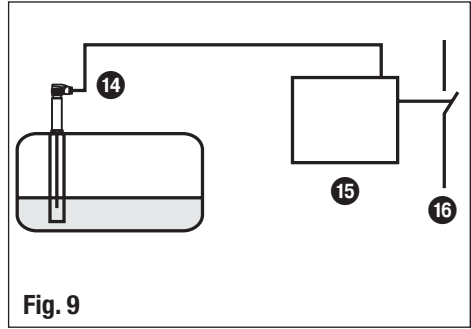
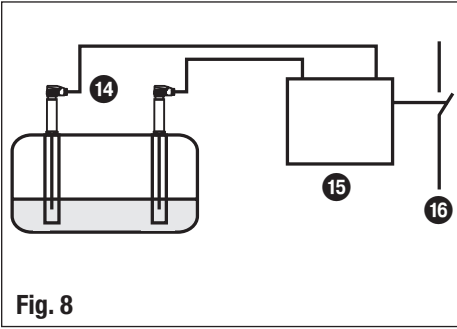

Fig. 7

Key

- 8 Mains supply
- 9 Signal output 1 / 2 for external alarm 24-230 V AC/DC 100 mA
- 10 Safety circuit, input and output
- 11 Wire link, on site, when used as water level limiter acc. to TRD, EN 12952 / EN 12953
- 12 Stand-by input 1 / 2, 24 V DC, for connecting the logic unit SRL 6-50
- 13 Level electrode NRG 1...-50, NRG 1...-11 or NRG 16-36

Schematic representations of arrangements



Key

- 14** Level electrode(s) NRG 1...-50
- 15** Level switch NRS 1-50
- 16** Safety circuit
- 17** Level switch NRS 1-50 for low-level pre-alarm

Explanatory notes to schematic representations

Steam boiler plants according to TRD 604, EN 12952-07 / EN 12953-06, 72 h operation

Fig. 8

Combination consisting of 2 level electrodes NRG 1...-50 and 1 level switch NRS 1-50 as water level limiter. Functional safety IEC 61508, SIL 3.

The equipment combination meets the demand for two independent water level limiters.

(Pressurized) hot-water plants and electrically heated steam boilers according to TRD 604, EN 12953-06

Steam boiler plants with high availability according to TRD 604, EN 12952-07 / EN 12953-06, 72h operation

Fig. 9

Combination consisting of 1 level electrode NRG 1...-50 and 1 level switch NRS 1-50 as water level limiter. Functional safety IEC 61508, SIL 3.

Hot water installations require two independent and separate water level limiters. For this purpose one equipment combination NRG 1...-50/NRS 1-50 shall be installed in the hot-water boiler and the second one in the pressure maintaining vessel, the expansion tank or the like (depending on the type of pressurization). For electrically heated steam boilers one water level limiter is sufficient.

To meet the plant operator's demand for a higher level of availability of the steam boiler plant, two (or three) independent equipment combinations NRG 1...-50/NRS 1-50 can be installed in the steam boiler.

Further applications in accordance with national sets of regulations

Fig. 10

Combination consisting of 1 level electrode NRG 1...-50 and 1 level switch NRS 1-50 as water level limiter.

The level switch opens two separate safety circuits. Functional safety IEC 61508, SIL 3.

Fig. 11

Combination consisting of 2 level electrodes NRG 1...-50 and 1 level switch NRS 1-50 as water level limiter.

The level switch opens two separate safety circuits. Functional safety IEC 61508, SIL 3.

Fig. 12

Combination consisting of 1 level electrode NRG 1...-50 and 1 level switch NRS 1-50 as water level limiter and 1 level electrode NRG 1...-50 / 1 level switch NRS 1-50 as first low-level alarm. Functional safety IEC 61508, SIL 3.

Fig. 13

Combination consisting of 2 level electrodes NRG 1...-50 and 2 level switches NRS 1-50 as water level limiter.

The level switch opens two separate safety circuits. Functional safety IEC 61508, SIL 3.



Note

- Please observe the safety-related characteristics for the equipment combination 1 level electrode NRG 1...-50 / NRG 16-36 / level switch NRS 1-50 and 2 level electrodes NRG 1...-50 / level switch NRS 1-50 on page 6, Fig. 1.

Basic Settings

Factory setting

Level Switch NRS 1-50

The level switch features the following factory set default values:

- De-energizing delay: 3 sec., 15 sec. for marine applications.
- Configuration: Operation with two level electrodes NRG 1 ...-50. S1/S2 of code switches ④ and ⑤ set to OFF.

Commissioning Procedure



Danger

The terminal strips of the NRS 1-50 are live during operation.

This presents the danger of electric shock!

Always **cut off power supply** to the equipment before mounting, removing or connecting the terminal strips!

Changing configuration

If only one electrode is used for operation (e. g. in case of emergency operation) change the settings as follows:

- Switch off mains voltage.
- Unscrew the right and left fixing screws ③ and remove the lower terminal strip ②, Fig. 6
- Depending on which electrode shall be deactivated, set S1/S2 of code switches ④ and ⑤ to ON.
- Attach lower terminal strip and fasten fixing screws.
- Apply mains voltage, equipment is re-started.



Toggle switch, white



Toggle switch, white

| | Code switch ④ | | Code switch ⑤ | |
|-------------------------------|---------------|-----|---------------|-----|
| | S 1 | S 2 | S 1 | S 2 |
| Level electrode 1 activated | OFF | | OFF | |
| Level electrode 1 deactivated | ON | | ON | |
| Level electrode 2 activated | | OFF | | OFF |
| Level electrode 2 deactivated | | ON | | ON |



Note

- If only one level electrode is switched on, only the LEDs for power and alarm of the corresponding channels will be illuminated.

Checking switchpoint and function

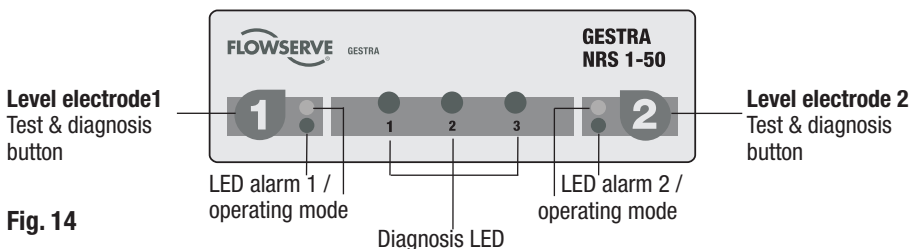

Fig. 14

| Start | | |
|--|---|---|
| Activity | Indication | Function |
| Apply mains voltage. | All LEDs are illuminated. | System is being started and tested, this takes approx. 10 sec. Output contacts are open. Signal outputs 1 and 2 are closed. |
| | All LEDs are illuminated for more than 10 sec. | System malfunction. Possible causes: Faulty power supply, level switch defective. |
| Raise water in boiler until the switchpoint "low water level (LW)" is exceeded. Level electrode(s) make(s) contact with the water. | Green LEDs for level electrode 1 / 2 illuminated. | Output contacts are closed. Signal outputs 1 and 2 open. |

| Checking switchpoint and function | | |
|--|--|--|
| Lower water level until it is below the switchpoint "low water level (LW)". Level electrode(s) is/are exposed. | Red LEDs for level electrode 1 / 2 are flashing. | De-energizing delay is running. Signal outputs 1 and 2 are closed instantaneously. |
| | Red LEDs for level electrode 1 / 2 illuminated. | Delay time has elapsed, output contacts open. Signal outputs 1 and 2 are closed. |

| Possible installation faults | | |
|--|---|---|
| Status and indication | Fault | Remedy |
| Sightglass indicates level below switchpoint "low water (LW)", red LEDs for level electrodes 1/2 not illuminated. Safety circuit closed. | Electrode rod(s) is/are too long. | Cut electrode rod(s) to the length dictated by the switchpoint LW. |
| | If installed inside the boiler: Upper vent hole in protection tube does not exist or is obstructed. | Check installation of level electrode. Make sure that the level in the protection tube corresponds to the actual water level. |
| Water level sufficient. Red LEDs for level electrodes 1 / 2 illuminated! Safety circuit open. | Electrode rod(s) is/are too short. | Replace electrode rod(s) and cut new rods to the length dictated by the switchpoint LW. |
| | The earth connection to the vessel is interrupted. | Clean seating surfaces and screw in level electrode with metallic joint ring. Do not insulate the electrode with hemp or PTFE tape! |
| | Electrical conductivity of the boiler water too low. | Set response sensitivity of the level switch to 0.5 $\mu\text{S}/\text{cm}$. |
| | Upper vent hole flooded. | Check installation of level electrode. Make sure that the level in the protection tube corresponds to the actual water level. |

Operation, Alarm and Test

Indicators and adjustors

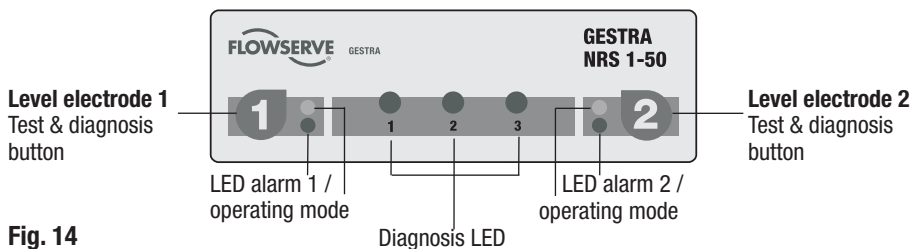

Fig. 14

| Operation | | |
|--|---|---|
| Activity | Indication | Function |
| Level electrode(s) submerged. | Green LEDs for level electrode 1 / 2 illuminated. | Output contacts are closed. Signal outputs 1 / 2 open. |
| Alarm | | |
| Level electrode(s) exposed, level below low water level (LW). | Red LEDs for level electrode 1 / 2 are flashing. | De-energizing delay is running. Signal outputs 1 / 2 are closed instantaneously. |
| | Red LEDs for level electrode 1 / 2 illuminated. | Delay time has elapsed, output contacts open. Signal outputs 1 / 2 are closed. |
| Test channel 1 and 2 | | |
| During operation: Press key 1 or 2 and hold it down until the end of the test, level switch must react as if there was an alarm. | Red LEDs for level electrode 1 / 2 are flashing. | Alarm simulated in channel 1 or 2. De-energizing delay is running. Signal outputs 1 / 2 are closed instantaneously. |
| | Red LEDs for level electrode 1 / 2 illuminated. | Delay time has elapsed, output contacts open. Signal outputs 1 / 2 are closed. Test finished. |

Troubleshooting

Indication, diagnosis and remedy



Attention

Before carrying out the fault diagnosis please check:

Mains supply:

Is the level switch supplied with the mains voltage specified on the name plate?

Wiring:

Is the wiring in accordance with the wiring diagram and the relevant schematic representation of arrangement?

Configuration: Are the code switch settings ④ and ⑤ correct for the number of level electrodes used?

Fault Indication and Troubleshooting – continued –

Indication, diagnosis and remedy – continued –

| Fault indication | | | |
|---|--|---|--|
| Status | Diagnosis | Function | Next activity |
| Faulty evaluation of level electrode 1, channel 1 | Diagnosis LED 1 and LED alarm 1 illuminated. | Output contacts are opened instantaneously. Signal output 1 closes instantaneously. | next: Press key 1 . |
| Faulty evaluation of level electrode 2, channel 2 | Diagnosis LED 2 and LED alarm 2 illuminated. | Output contacts are opened instantaneously. Signal output 2 closes instantaneously. | next: Press key 2 . |
| Malfunction in level switch detected. | Diagnosis LED 3 and LED alarm 1 and 2 illuminated. | Output contacts are opened instantaneously. Signal outputs 1 and 2 are closed instantaneously. | next: Press key 1 or key 2 . |

| Diagnosis | | | |
|--|---------------------------|---|--|
| Display 1 and activity | Display 2 | Fault | Remedy |
| LED alarm 1 and diagnosis LED 1 illuminated. Press and hold down key 1 . | Diagnosis LED 1 flashing. | Malfunction in level electrode 1, malfunction in level switch, faulty wiring, faulty measuring voltage. | <ul style="list-style-type: none"> – check wiring, – measure electrode voltages, – clean and, if necessary, exchange level electrode, – exchange level switch. |
| | Diagnosis LED 2 flashing. | Malfunction in level electrode 1, malfunction in level switch, faulty wiring. | |
| | Diagnosis LED 3 flashing. | Interference voltage causing malfunction, boiler earth without PE | Provide screen and earthing, connect boiler with PE. |
| LED alarm 2 and Diagnosis LED 2 illuminated. Press and hold down key 2 | Diagnosis LED 1 flashing. | Malfunction in level electrode 2, malfunction in level switch, faulty wiring, faulty measuring voltage. | <ul style="list-style-type: none"> – check wiring, – measure electrode voltages, – clean and, if necessary, exchange level electrode, – exchange level switch. |
| | Diagnosis LED 2 flashing. | Malfunction in level electrode 2, malfunction in level switch, faulty wiring. | |
| | Diagnosis LED 3 flashing. | Interference voltage causing malfunction, boiler earth without PE. | Provide screen and earthing, connect boiler with PE. |
| LED alarm 1 and 2 and Diagnosis LED 3 illuminated. Press and hold down key 1 or 2 . | Diagnosis LED 1 flashing. | Malfunction in processor, stand-by fault. | Observe operating instructions for the logic unit SRL. Replace level switch. Replace level switch. |
| | Diagnosis LED 2 flashing. | Internal voltage fault. | |
| | Diagnosis LED 3 flashing. | Malfunction in relay. | |

Once the fault is eliminated, the level switch returns to normal operation.

After elimination of the fault switch off the mains voltage and switch it on again after approx. 5 sec.

Checking Level Electrodes

Measuring voltage across level electrode

Measure the electrode voltage in order to check whether the level electrode is immersed or if there is a malfunction. Please observe **Fig. 15**.

| U_{1-2} | $U_{1-\perp}$ | | $U_{2-\perp}$ |
|-----------------------------------|-----------------------|--------------------------|-------------------------------|
| | immersed | exposed | Malfunction (immersed/ alarm) |
| $\approx 0.7\text{ V}$ 85 Hz ! | $< \frac{U_{1-2}}{2}$ | $\geq \frac{U_{1-2}}{2}$ | $\leq U_{1-\perp}$ |

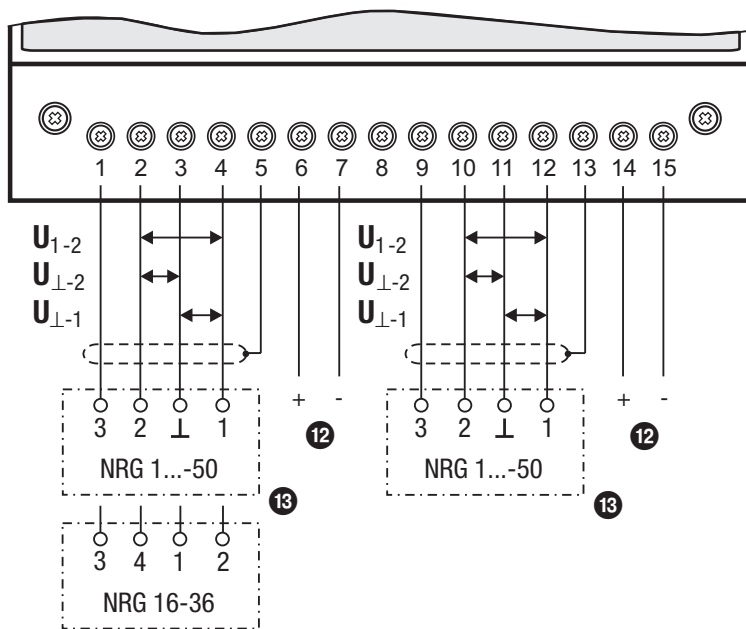

Fig. 15

Key

- 12 Stand-by input 1 / 2, 24 V DC, for connecting the logic unit SRL
- 13 Level electrode NRG 1...-50, NRG 1...-11, NRG 16-36



Note

- The self-checking routine of the level switch NRS 1-50 reduces U_{1-2} to 0 Volt, if executed cyclically.

Emergency operation

Emergency operation for water level limiter

If the level switch NRS 1-50 works with two level electrodes NRG 1...-50 (water level limiter to TRD 604, EN 12952-07, EN 12953-06), the installation can continue operating in emergency operation mode according to TRD 401 and EN 12952 and EN 12953 under constant supervision with **only 1** level electrode, in case that one of the two installed level electrodes fails.

If only one electrode is used for operation change the settings as follows:

- Switch off mains voltage.
- Unscrew the right and left fixing screws ③ and remove the lower terminal strip ②, Fig. 6
- Depending on which electrode shall be deactivated, set S1 or S2 of code switches ④ and ⑤ to ON.
- Attach lower terminal strip and fasten fixing screws.
- Apply mains voltage, equipment is re-started.



Toggle switch, white



Toggle switch, white

| | Code switch ④ | | Code switch ⑤ | |
|-------------------------------|---------------|-----|---------------|-----|
| | S 1 | S 2 | S 1 | S 2 |
| Level electrode 1 activated | OFF | | OFF | |
| Level electrode 1 deactivated | ON | | ON | |
| Level electrode 2 activated | | OFF | | OFF |
| Level electrode 2 deactivated | | ON | | ON |



Attention

- Record the beginning of emergency operation in the boiler log.
- An installation operating in emergency mode has to be constantly supervised.
- Immediately replace faulty level electrode.
- Record the end of emergency operation in the boiler log.
- When the emergency operation is over, restore original settings.

If faults occur that are not listed above or cannot be corrected, please contact our service centre or authorized agency in your country.

Further Notes

Action against high frequency interference

Should sporadic failures occur in installations susceptible to faults (e. g. malfunctions due to out-of-phase switching operations) we recommend the following actions in order to suppress interferences:

- Provide inductive loads with RC combinations according to manufacturer's specification to ensure interference suppression.
- Increase the distance to sources of interference.
- Check screens and shields.
- HF interference suppression by means of hinged-shell ferrite rings.

Interlock and interlock deactivation

In the event of an alarm the level switch NRS 1-50 does not interlock automatically.

If a lock function is required by the installation it must be provided in the follow-up circuitry (safety circuit). The circuitry must meet the requirements of the EN 50156.

Checking the switchpoints

To check the switchpoint "Low water (LW)" you have to lower the water level. When the water level falls below the electrode tip, the level switch must activate an alarm and the safety circuit must open as soon as the de-energizing time delay has elapsed. The switching-off of the heating is interlocked in the safety circuit and can only be deactivated when the level electrode enters the water again. Always check the switchpoint when commissioning the equipment, after replacing the level electrode and at regular intervals, e.g. every year.

Decommissioning / replacing level switch

- Switch off mains voltage and **cut off power supply** to the equipment.
- Unscrew the right and left fixing screws ③ and remove the upper and lower terminal strips ① ②, **Fig. 6**
- Release the white fixing slide at the bottom of the equipment and take the equipment off the supporting rail.

Disposal

For the disposal of the level switch observe the pertinent legal regulations concerning waste disposal.

Note on the Declaration of Conformity / Declaration by the Manufacturer C E

For details on the conformity of our equipment according to the European Directives see our Declaration of Conformity or our Declaration of Manufacturer.

The current Declaration of Conformity / Declaration of Manufacturer are available in the Internet under www.gestra.de/documents or can be requested from us.

For your notes

For your notes

For your notes



GESTRA

Agencies all over the world:

www.gestra.de

España

GESTRA ESPAÑOLA S.A.

Luis Cabrera, 86-88

E-28002 Madrid

Tel. 0034 91 / 5 15 20 32

Fax 0034 91 / 4 13 67 47; 5 15 20 36

E-mail: aromero@flowserve.com

Polska

GESTRA POLONIA Spolka z.o.o.

Ul. Schuberta 104

PL - 80-172 Gdansk

Tel. 0048 58 / 3 06 10 - 02

0048 58 / 3 06 10 - 10

Fax 0048 58 / 3 06 33 00

E-mail: gestra@gestra.pl

Great Britain

Flowserve GB Limited

Abex Road

Newbury, Berkshire RG14 5EY

Tel. 0044 16 35 / 46 99 90

Fax 0044 16 35 / 3 60 34

E-mail: gestraukinfo@flowserve.com

Portugal

Flowserve Portuguesa, Lda.

Av. Dr. Antunes Guimarães, 1159

Porto 4100-082

Tel. 00351 22 / 6 19 87 70

Fax 00351 22 / 6 10 75 75

E-mail: jtavares@flowserve.com

Italia

Flowserve S.p.A.

Flow Control Division

Via Prealpi, 30

I-20032 Cormano (MI)

Tel. 0039 02 / 66 32 51

Fax 0039 02 / 66 32 55 60

E-mail: infoitaly@flowserve.com

USA

Flowserve GESTRA U.S.

2341 Ampere Drive

Louisville, KY 40299

Tel. 001 502 / 267-2205

FaxL 001 502 / 266-5397

E-mail: FCD-Gestra-USA@flowserve.com

GESTRA AG

P. O. Box 10 54 60, D-28054 Bremen

Münchener Str. 77, D-28215 Bremen

Telephone 0049 (0) 421 35 03 - 0

Fax 0049 (0) 421 35 03 - 393

E-Mail gestra.ag@flowserve.com

Internet www.gestra.de

