



FLOWSERVE



GESTRA

GESTRA Steam Systems

NRR 2-50

NRR 2-51

EN
English

Installation & Operating Instructions
819180-01

Level Controller NRR 2-50

Level Controller NRR 2-51

Contents

Page

Important Notes

Usage for the intended purpose	4
Function	4
Safety note	5

Directives and Standards

VdTÜV Bulletin "Wasserstand 100" (= Water Level 100)	5
LV (Low Voltage) Directive and EMC (Electromagnetic Compatibility)	5
ATEX (Atmosphère Explosible)	5
Note on the Declaration of Conformity / Declaration by the Manufacturer CE	5
Approvals for Marine Applications	5

Technical data

NRR 2-50, NRR 2-51	6 – 7
Scope of supply	7

In control cabinet: Mounting level controller

Dimensions NRR 2-50, NRR 2-51	8
Key	8
Installation in control cabinet	8
Name plate / marking	9

In control cabinet: Wiring level controller

Wiring diagram for level controller NRR 2-50,	10
Key	10
Wiring diagram for level controller NRR 2-51,	11
Key	11
Connecting supply voltage	12
Connecting output contacts	12
Connecting level electrode, level transmitter	12
Output for manipulated variable Y or connection of actual-value output (option)	12
Tools	12

In the plant: Wiring level electrode / level transmitter

Connecting level electrode, level transmitter	13
---	----

Factory settings

Factory setting	13
-----------------------	----

Contents - continued -

Page

Changing factory settings

Changing function and input for level electrode / transmitter	14 - 15
---	---------

Operating level controller

Key to codes on seven-segment display	16
Establishing measuring range	17
Additional information on control parameter settings	17

Commissioning procedure

Parameter setting	18
Establishing measuring range, switchpoints and control parameters	19

Operation, alarm and test

Level controller NRR 2-50, indications	20
Level controller NRR 2-51, indications	21
Checking functions of MIN / MAX output contacts	21

Troubleshooting

Indication, diagnosis and remedy	22
--	----

Further notes

Protection against high frequency interference	23
Decommissioning / replacing the equipment	23
Disposal	23

Important Notes

Usage for the intended purpose

The level controller NRR 2-50 / NRR 2-51 in conjunction with level electrodes NRG 2... and level transmitter NRG 26-1 is used as limit switch and water level controller, for instance in steam boilers, (pressurized) hot-water installations as well as condensate and feedwater tanks. The level controller indicates when the preset water level limit MIN/MAX is reached and opens or closes the control valve accordingly.

The level controller NRR 2-50 / NRR 2-51 is designed to be used with level electrodes NRG 21... and NRG 26-21 as well as the level transmitter NRG 26-1.

Function

The **level controller NRR 2-50, NRR 2-51** uses the level-dependent voltage signal emitted by the level electrodes NRG 2... or the level-dependent current signal emitted by the level transmitter NRG 26-1. These input signals are standardized by the controller to 0 and 100 % of the boiler measuring range and indicated as actual value by the seven-segment LED display.

Level controller NRR 2-50: The level controller works in conjunction with an electrically actuated control valve as three-position stepping controller with proportional-plus-integral control action (**PI controller**). In the event of a deviation from the setpoint, the electrical actuator is controlled by two output contacts and two flashing LEDs indicate whether the control valve opens or closes.

The controller can be configured for fill or discharge control.

An additional output contact indicates when the MIN or MAX water level is reached (the desired function is switch-selectable). After the de-energizing delay has elapsed, the output contact switches over and the LED for MIN or MAX is illuminated.

Level controller NRR 2-51: The level controller works in conjunction with an electro-pneumatically actuated control valve as continuous controller with proportional-plus-integral control action (**PI controller**) and, in the event of a deviation from the setpoint, outputs a current of 4-20 mA as manipulated variable Y.

The controller can be configured for fill or discharge control.

When the MIN or MAX water level is reached, the MIN or MAX output contact is switched over in the level controller after the de-energizing delay and the MIN or MAX LED is illuminated .

Level controller NRR 2-50, NRR 2-51: Any faults or malfunctions in the level electrode, the level transmitter, the electrical connection or the settings will be indicated as error code by the seven-segment LED display. In the event of a malfunction a MIN and MAX alarm will be triggered.

If errors occur only in the **level controller NRR 2-50 / NRR 2-51**, a MIN and MAX alarm is raised and the system is restarted.

Parameter settings can be changed or a MIN/MAX alarm be simulated by operating the rotary button.

For external level indication the **level controller NRR 2-50** is optionally available with an actual-value output 4 - 20 mA.

Important Notes - continued -

Safety note

The equipment must only be installed, wired and commissioned by qualified and competent staff. Retrofitting and maintenance work must only be performed by qualified staff who - through adequate training - have achieved a recognised level of competence.



Danger

The terminal strips of the equipment are live during operation. This presents the danger of electric shock!

Always cut off power supply to the equipment before mounting, removing or connecting the terminal strips!



Attention

The name plate specifies the technical features of the equipment. Note that any piece of equipment without its specific name plate must neither be commissioned nor operated.

Directives and Standards

VdTÜV Bulletin “Wasserstand 100” (= Water Level 100)

The level controller NRR 2-50 / NRR 2-51 in conjunction with level electrode NRG 2-.. and level transmitter NRGT 26-1 is type approved to VdTÜV Bulletin “Water Level 100”. The VdTÜV Bulletin “Wasserstand (= Water Level) 100” specifies the requirements made on water level control and limiting equipment for boilers.

LV (Low Voltage) Directive and EMC (Electromagnetic Compatibility)

The equipment meets the requirements of the Low Voltage Directive 2006/95/EC and the EMC Directive 2004/108/EC.

ATEX (Atmosphère Explosible)

According to the European Directive 94/9/EC the equipment must **not** be used in explosion risk areas.

Note on the Declaration of Conformity / Declaration by the Manufacturer CE

For details on the conformity of our equipment according to the European Directives see our Declaration of Conformity or our Declaration of Manufacturer. The current Declaration of Conformity / Declaration of Manufacturer are available in the Internet under www.gestra.com/documents or can be requested from us.

Approvals for Marine Applications

The level controller NRR 2-5.. in conjunction with level transmitter NRGT 26-1 is approved for marine applications.

Technical data

NRR 2-50, NRR 2-51

Supply voltage

24 VDC +/- 20 %

Fuse

external 0.5 A (semi-delay)

Power consumption

4 VA

Connection of level electrode / level transmitter (switch-selectable)

1 input for level electrode NRG 21-.. and NRG 26-21, with 3 poles and screen or

1 analog input 4-20 mA, e. g. for level transmitter NRGT 26-1, with 2 poles and screen or

Supply voltage of level electrode

12 VDC

Outputs

NRR 2-50: 2 volt-free change-over contacts, 8 A 250 V AC / 30 V DC $\cos \varphi = 1$
(control valve open/closed).

1 volt-free change-over contact, 8 A 250 V AC / 30 V DC $\cos \varphi = 1$.

De-energizing delay: 3 sec. (MIN / MAX alarm, switch-selectable).

NRR 2-51: 2 volt-free change-over contacts, 8 A 250 V AC / 30 V DC $\cos \varphi = 1$.

De-energizing delay: 3 sec. (MIN / MAX alarm)

1 analog output 4-20 mA, max. load 500 ohm (manipulated variable Y).

Provide inductive loads with RC combinations according to manufacturer's specification to ensure interference suppression.

NRR 2-50: 1 analogue output 4-20 mA, max. load 500 ohm, e. g. for actual-value indication (optional).

Indicators and adjustors

1 rotary button with integrated pushbutton "Test" for simulating MIN / MAX alarm and setting the parameter,

1 seven-segment LED display, four digits, green

2 LEDs red for MIN / MAX alarm,

2 LEDs amber for control valve opens/closes (only NRR 2-50)

1 four-pole code switch for configuration settings

Housing

Housing material: base: polycarbonate, black; front: polycarbonate, grey

Conductor size: 1 x 4.0 mm² solid, per wire, or

1 x 2.5 mm² per stranded wire with sleeve to DIN 46228 or

2 x 1.5 mm² per stranded wire with sleeve to DIN 46228 (min. \varnothing 0.1 mm)

Terminal strips can be detached

Fixing of housing: Mounting clip on supporting rail TH 35, EN 60715

Electrical safety

Pollution degree 2 for installation in control cabinet with protection IP 54, completely insulated

Protection

Housing: IP 40 to EN 60529

Terminal strip: IP 20 to EN 60529

Weight

approx. 0.2 kg

Technical Data - continued -

NRR 2-50, NRR 2-51 - continued -

Ambient temperature

when system is switched on: 0 ° 55 °C, during operation: -10 ... 55 °C

Transport temperature

-20 ... +80 °C (<100 hours), defrosting time of the de-energized equipment before it can be put into operation: 24 hours.

Storage temperature

-20 ... +70 °C, defrosting time of the de-energized equipment before it can be put into operation: 24 hours.

Relative humidity

max. 95 %, no moisture condensation

Approvals:

TÜV certificate VdTÜV Bulletin "Water Level 100" (= Water Level 100):
Requirements made on water level limiting & control equipment.
Type approval no. TÜV · WR · XX-425 (see name plate)

Scope of supply

NRR 2-50

1 Level controller NRR 2-50
1 Installation manual

NRR 2-51

1 Level controller NRR 2-51
1 Installation manual

In control cabinet: Mounting level controller

Dimensions NRR 2-50, NRR 2-51

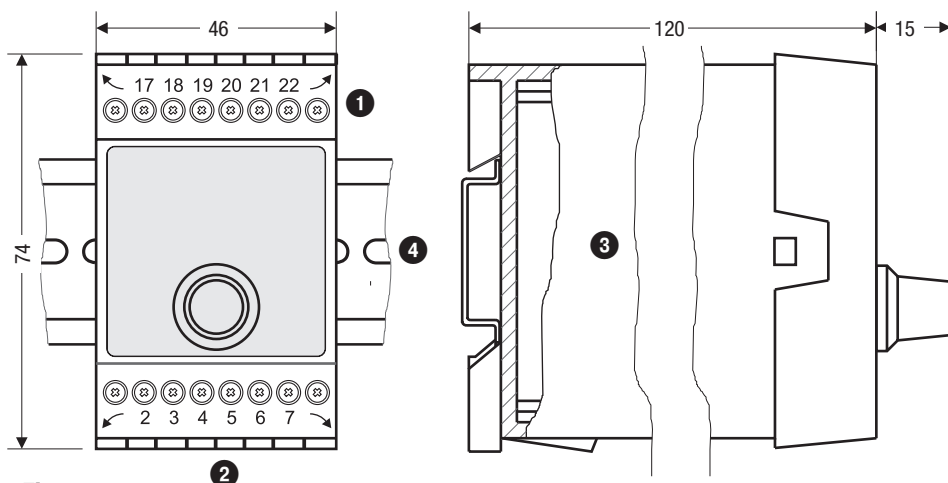

Fig. 1

Key

- | | | | |
|---|----------------------|---|--------------------------------------|
| 1 | Upper terminal strip | 3 | Housing |
| 2 | Lower terminal strip | 4 | Supporting rail type TH 35, EN 60715 |

Installation in control cabinet

The level controller NRR 2-50, NRR 2-51 is clipped onto the support rail type TH 35, EN 60715 in the control cabinet. **Fig. 1** 4

Name plate / marking

Name plate NRR 2-50 (top)

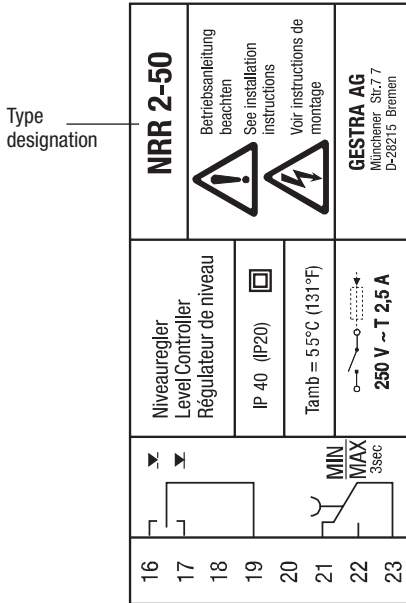

Name plate NRR 2-51 (top)

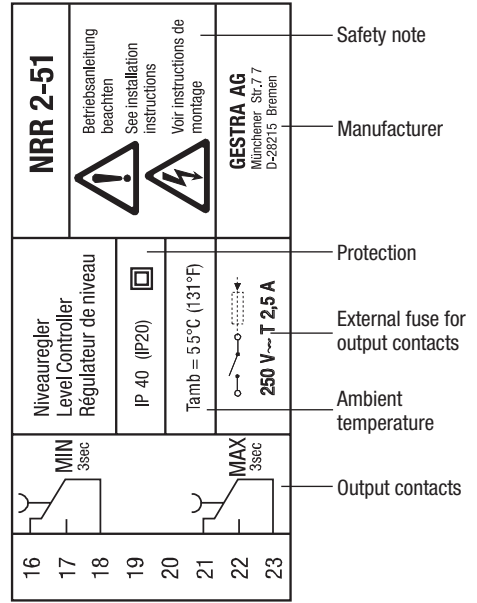

Name plate (at the bottom)

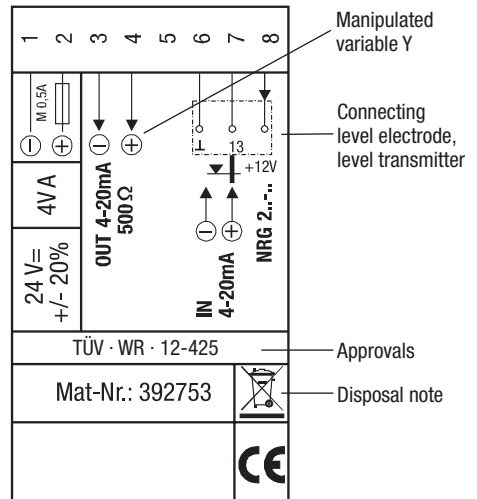
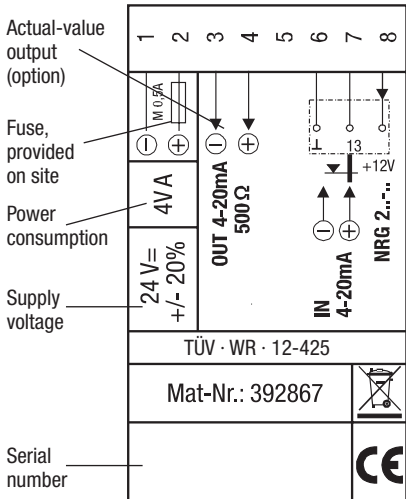

Fig. 2

In control cabinet: Wiring level controller

Wiring diagram for level controller NRR 2-50

NRR 2-50

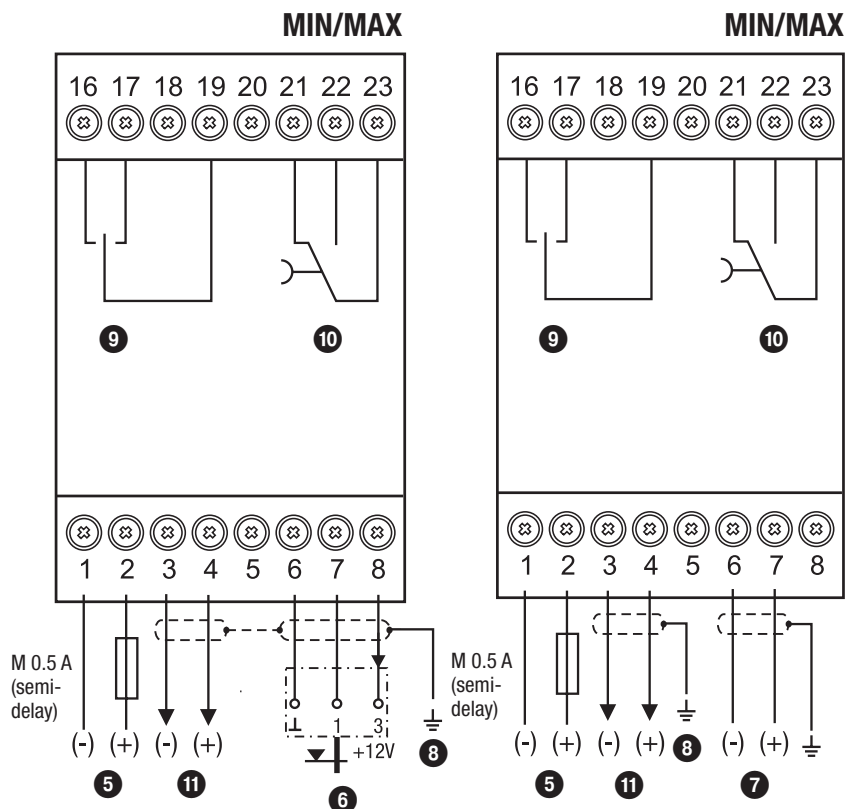

Fig. 3

Key

- 5 Connection of supply voltage **24 V DC** with fuse 0.5 A (semi-delay) provided on site
- 6 Level electrode NRG 21-.. NRG 26-21.
Up to three NRS/NRR 2-5.. can be connected (parallel connection).
- 7 Level transmitter NRG 26-1, 4-20 mA, with earthing point.
Up to three NRS/NRR 2-5.. can be connected (series connection).
- 8 Central earthing point (CEP) in control cabinet
- 9 Output contact for activating the control valve
- 10 MIN / MAX output contact, de-energizing delay: 3 sec.
- 11 Actual value output 4-20 mA (optional)

Wiring diagram for level controller NRR 2-51

NRR 2-51

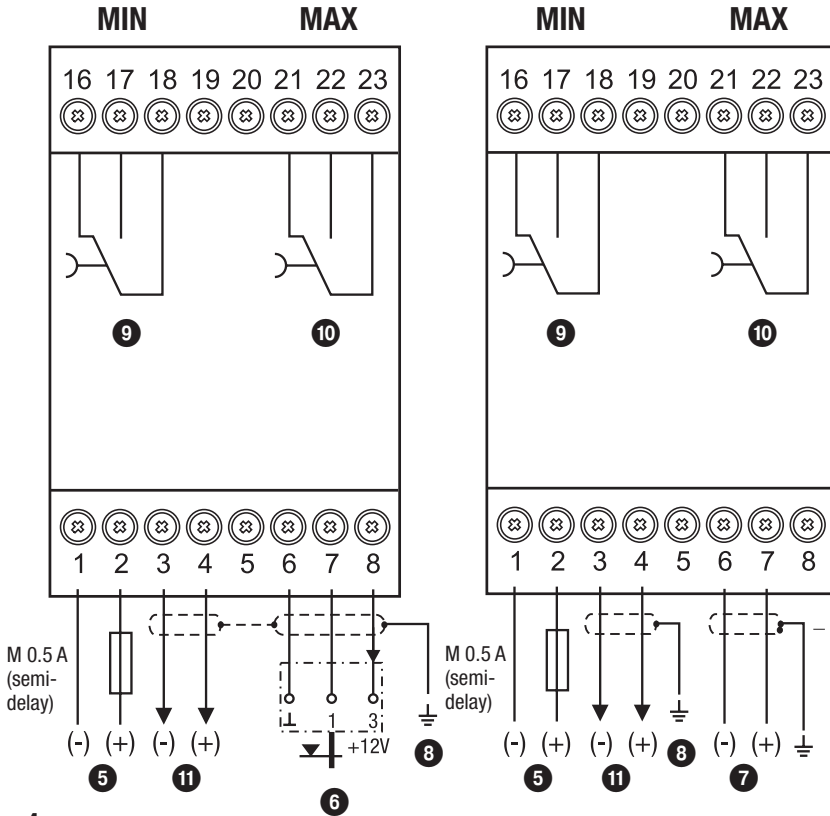

Fig. 4

Key

- 5** Connection of supply voltage **24 V DC** with fuse 0.5 A (semi-delay) provided on site
- 6** Level electrode NRG 21.. NRG 26-21.
Up to three NRS/NRR 2-5.. can be connected (parallel connection).
- 7** Level transmitter NRG 26-1, 4-20 mA, with earthing point.
Up to three NRS/NRR 2-5.. can be connected (series connection).
- 8** Central earthing point (CEP) in control cabinet
- 9** MIN output contact, de-energizing delay: 3 sec.
- 10** MAX output contact, de-energizing delay: 3 sec.
- 11** Output 4-20 mA manipulated variable Y

In control cabinet: Wiring level controller - continued -

Connecting supply voltage

The equipment is supplied with 24 V DC and fused with an external semi-delay fuse 0.5 A. Please use a safety power supply unit with safe electrical isolation.

The power supply unit must be electrically isolated from dangerous contact voltages and must meet at least the requirements on double or reinforced isolation according to one of the following standards: DIN EN 50178, DIN EN 61010-1, DIN EN 60730-1 or DIN EN 60950.

Connecting output contacts

Wire the upper terminal strip ① (terminals 16-23) according to the desired switching functions.

Provide an external slow-blow fuse 2.5 A for the output contacts.

When switching off inductive loads, voltage spikes are produced that may impair the operation of control and measuring systems. Connected inductive loads must be provided with suppressors such as RC combinations as specified by the manufacturer.

Connecting level electrode, level transmitter

To connect the equipment use screened multi-core control cable with a min. conductor size 0.5 mm², e. g. LiYCY 4 x 0.5 mm², max. length: 100 m. Up to three level switches/controllers NRS/NRR 2-5.. can be connected to one level electrode or one level transmitter.

Wire terminal strip in accordance with the wiring diagram. **Fig. 3, 4**

Wire screen in accordance with the wiring diagram.

Make sure that connecting cables leading to the equipment are segregated and run separately from power cables.

Output for manipulated variable Y or connection of actual-value output (option)

To connect the equipment use screened multi-core control cable with a min. conductor size 0.5 mm², e. g. LiYCY 2 x 0.5 mm², max. length: 100 m.

Please observe the max. load of 500 ohm (output of manipulated variable Y).

Wire terminal strip in accordance with the wiring diagram. **Fig. 3, 4**

Connect the screen **only once** to the central earthing point (CEP) in the control cabinet.

Make sure that connecting cables leading to the equipment are segregated and run separately from power cables.

Any item of equipment that you want to connect to the terminals for the output of manipulated variable Y or actual-value output 4 - 20 mA (option) must be certified to have at least double or reinforced isolation according to DIN EN 50178 or DIN EN 61010-1 or DIN EN 60730-1 or DIN EN 60950 (safe electrical isolation) between the current loop and live parts of the equipment that are not supplied with safety extra-low voltage (SELV).



Attention

- Do not use unused terminals as support point terminals.

Tools

- Screwdriver for slotted screws, size 3.5 x 100 mm, completely insulated according to VDE 0680-1.

In the plant: Wiring level electrode / level transmitter

Connecting level electrode, level transmitter

The level controller NRR 2-50 / NRR 2-51 is designed to be used with level electrodes NRG 21-.. or NRG 26-21 as well as the level transmitter NRG 26-1.

To connect the equipment use screened multi-core control cable with a min. conductor size 0.5 mm², e. g. LiYCY 4 x 0.5 mm², max. length: 100 m.

Wire screen in accordance with the wiring diagram.



Attention

- To put the equipment into operation follow the instructions given in the installation & operating manuals for NRG 21-.., NRG 26-21 or NRG 26-1.
- Make sure that connecting cables leading to the equipment are segregated and run separately from power cables.
- The level transmitter must be separately connected to its own voltage supply.

Factory settings

Level Controller NRR 2-50

- De-energizing delay: 3 sec., factory set
- Voltage input for connecting a level electrode type NRG 21-.. or type NRG 26-21.
- MAX switchpoint AL.Hi = 80 %
- MIN switchpoint AL.Lo = 20 %
- Setpoint SP = 50 %
- Proportional band Pb = 20 %
- Integral action time ti = 0 %
- Dead band = +/- 5 % of the setpoint
- Valve travel time tt = 40 s
- Calibration value CAL.P = 100 %
- Function "Fill control"
- MIN / MAX output contact set as MAX alarm

Code switch 13: S1,S2,S3, S4 OFF

Level Controller NRR 2-51

- De-energizing delay: 3 sec., factory set
- Voltage input for connecting a level electrode type NRG 21-.. or type NRG 26-21.
- MAX switchpoint AL.Hi = 80 %
- MIN switchpoint AL.Lo = 20 %
- Setpoint SP = 50 %
- Proportional band Pb = 20 %
- Integral action time ti = 0 %
- Dead band = +/- 5 % of the setpoint
- Calibration value CAL.P = 100 %
- Function "Fill control"

Code switch 13: S1,S2,S3, S4 OFF

Changing factory settings



Danger

The upper terminal strip of the equipment is live during operation.

This presents the danger of electric shock!

Always **cut off power supply** to the equipment before mounting, removing or connecting the terminal strips!

Changing function and input for level electrode/transmitter

The input and the function are determined by the code switch **13** setting.

To change the code switch setting proceed as follows:

- Cut off supply voltage.
- Remove **lower** terminal strip. **Fig. 5**
 - Insert a screwdriver to the right and left of the arrow markings between the terminal strip and the front frame.
 - Unlock terminal strip on the left and right side. For this purpose move screwdriver in direction of the arrow .
 - Remove the terminal strip.

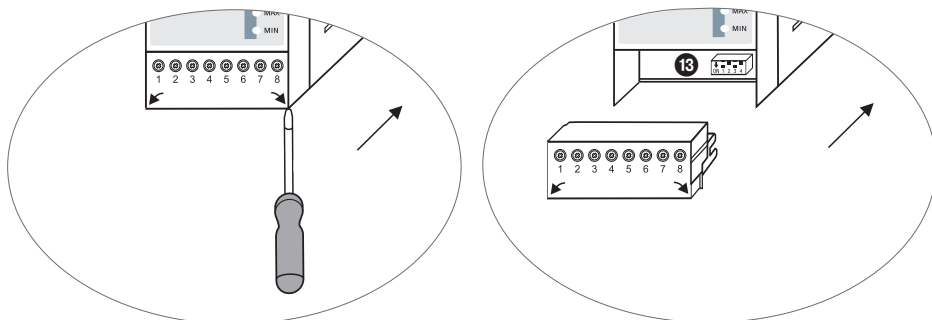

Fig. 5

After the new code switch settings have been established as new defaults:

- Re-attach lower terminal strip.
- Apply supply voltage. Equipment is restarted.

Changing factory settings - continued -

Changing function and input for level electrode / transmitter

If you want to change the input or the function, set the switches S1 to S3 of the code switch 13 as indicated in the following table Fig. 6.

Code switch 13			
 Toggle switch, white			
Level Controller NRR 2-50	S 1	S 2	S 3
Output contact set for MAX alarm	OFF		
Output contact set for MIN alarm	ON		
Level controller NRR 2-50, NRR 2-51			
Input for connecting level electrode NRG 21-.. or NRG 26-21			OFF
Input for connecting level transmitter NRGT 26-1 *			ON
Fill control		OFF	
Discharge control		ON	

Fig. 6

grey = factory setting



Attention

* When connecting level transmitter NRGT 26-1 set the upper and the lower end of the measuring range **only** in the transmitter. For this purpose follow the instructions given in the installation & operating manual for the NRGT 26-11.

Do **not** change the code switch 13 settings of S4!

Operating level controller

Key to codes on seven-segment display

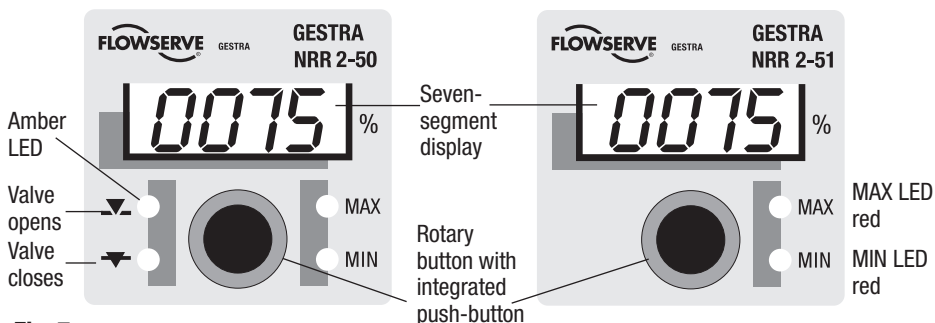

Fig. 7

Code	Description	
Indicated when rotary button is turned to the right:		
AL.Hi	Alarm High	MAX switchpoint
AL.Lo	Alarm Low	MIN switchpoint
SP	Setpoint	Setpoint
Pb	Proportional band	Proportional band, adjustable between 0 and 100 %
ti	Time integral	Integral action time, adjustable between 0 and 100 sec.
tt	Motor travel time	Valve travel time (only NRR 2-50), adjustable between 10 and 600 sec.
tESt	Test	Tests output relays

CAL.L	Calibrate Low	only if level electrode NRG 21-.. or NRG 26-21 is connected	establish lower end of measuring range
CAL.P	Calibrate %		adjustable between 25 and 100 %
CAL.H	Calibrate High		establish upper end of measuring range

Indicated when in parameterization mode:		
quit	Quit	Input not confirmed
done	Done	Input confirmed

Indicated if malfunctions occur:		
E.005	Error	Level electrode/transmitter defective, measuring voltage/current too low
E.006	Error	Level electrode/transmitter defective, measuring voltage/current too high
E.012	Error	Beginning and end of measuring range have been switched round.
E.013	Error	MIN switchpoint above MAX switchpoint

Operating level controller - continued -

Establishing measuring range

- A** Lower end of measuring range, adjustable
- B** Upper end of measuring range, adjustable
- C** Measuring range [mm] = xxx %
- D** Inactive range
- E** Max. length of installation 238 °C

Adjust the lower and upper end of the measuring range for level control. The resulting measuring range **C** is the active control range. Please calculate the percentage value of the measuring range.

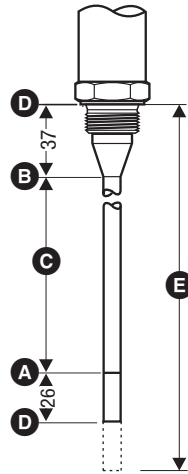

**NRG 2...
NRGT 26-1**



Attention

* When connecting level transmitter NRGT 26-1 set the upper and the lower end of the measuring range **only** in the transmitter.

Additional information on control parameter settings

Parameter	Deviation	Control valve
Proportional band Pb	larger	large remaining deviation
	smaller	small remaining deviation
Example	Measuring range 100% = 200 mm of sightglass Setpoint SP = 80 % of measuring range = 160 mm Proportional band Pb = +/- 20% of setpoint = +/- 16% = +/- 32 mm If the measuring range is 100% (200 mm) and the setpoint 80 % (160 mm), the proportional band will be +/- 16 % (+/- 32 mm) or within the range of 128 to 192 mm.	responds slowly responds quickly and may open/closes all the time
Integral action time ti	larger	slow correction of deviations
	smaller	fast correction of deviations, control system may tend to overshoot

Commissioning procedure

Setting parameters

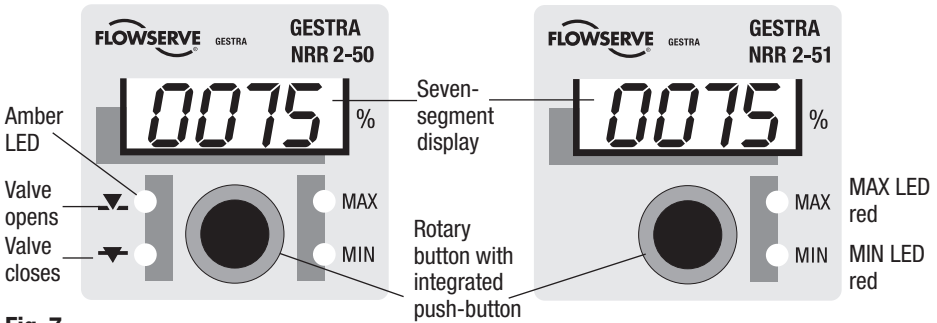

Fig. 7

Start		
Activity	Display	Function
Switch on supply voltage. Water level between MIN and MAX.	Seven-segment display shows equipment and software version.	System test, takes approx. 3 sec.
	Seven-segment display shows actual value	System switches to operating mode.

Setting parameters		
Activity	Seven-segment display	Function
Turn rotary button until the desired parameter is indicated.	Display toggles between parameter and the saved value setting.	For selecting the parameter
Press and hold down the push-button (of the rotary button)	First digit (000 <u>0</u>) flashing.	Parameterization mode active. You can change the first digit.
Turn rotary button.	A new value is indicated.	To increase the value turn rotary button to the right, to decrease turn it to the left.
Press push-button briefly.	2nd, 3rd or 4th digit is flashing. (from right to left)	2nd, 3rd or 4th digit can be changed by turning the rotary button. To increase the value turn rotary button to the right, to decrease turn it to the left.
<i>If no further operation is performed:</i>	“quit” is indicated for a moment. Then the display toggles between parameter and the old value setting.	If the input is not confirmed the system switches automatically back to the parameter.
After the input has been finished: Press and hold down the push-button.	“done” is indicated for a moment. Then the display toggles between parameter and the new value setting.	Input is confirmed. System switches back to parameter.
Turn rotary button until the next parameter is indicated. Or turn the rotary button until the actual value is shown. If no operation is performed the actual value will be indicated automatically after 30 sec.		

Establishing measuring range, switchpoints and control parameters

Only for level electrode NRG 2.-. : Adjusting measuring range, first possibility	
Activity	Function
Lower water level until beginning of measuring range A is reached. Select parameter CAL.L and save the indicated value.	Lower end of measuring range is calibrated. CAL.L is indicated in hexadecimal code. (actual-value output = 4 mA)
Raise water level until end of measuring range B is reached. Select parameter CAL.H and save the indicated value.	Upper end of measuring range is calibrated. CAL.H is indicated in hexadecimal code. (actual-value output = 20 mA)

Only for level electrode NRG 2.-. : Adjusting measuring range, second possibility	
Lower water level until beginning of measuring range A is reached. Select parameter CAL.L and save the indicated value.	Lower end of measuring range is calibrated. CAL.L is indicated in hexadecimal code.
Raise water level until at least 25 % of the measuring range is reached. Select parameter CAL.H and save the indicated value.	E. g. 25 % of the measuring range is calibrated. CAL.H is indicated in hexadecimal code.
Select parameter CAL.P, then adjust and save e. g. 25 %.	CAL.P interpolates the value measured at CAL.H to find the 100 % value of the measuring range. CAL.P can be adjusted between 25 and 100 %.

Setting MIN/MAX switchpoints	
Select parameter AL.Lo, set the desired percentage value and save the setting.	MIN switchpoint setting between 0 - 100 %.
Select parameter AL.Hi, set the desired percentage value and save the setting.	MAX switchpoint setting between 0 - 100 %.

Setpoint setting	
Select parameter SP, set the desired percentage value and save the setting.	Setpoint setting between 0 - 100 %. Please take the settings for the MIN/MAX switchpoints into consideration.

Setting proportional band	
Select parameter Pb, set the desired percentage value and save the setting.	Proportional band setting between 0 - 100 %.

Setting integral action time	
Select parameter ti, set the desired time and save the setting.	Setting integral action time between 0 - 100 sec.

Setting valve travel time (only NRR 2-50)	
Select parameter tt, set the desired time and save the setting.	Setting integral action time between 10 - 600 sec.



Note

- Adjusting measuring range: The second possibility has the advantage that you have to fill the vessel only partly.

Operation, alarm and test

Level controller NRR 2-50, indications

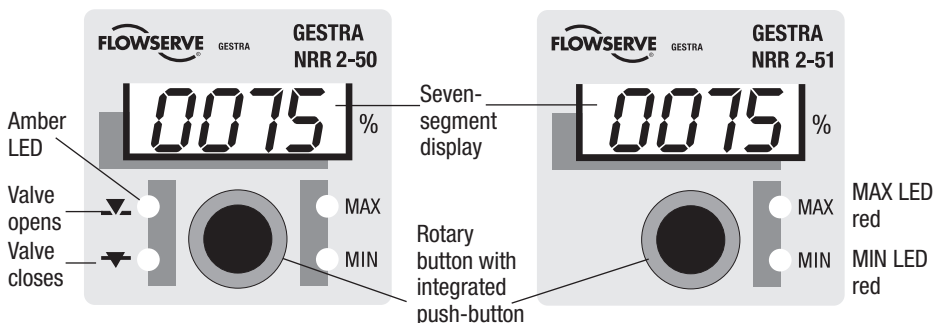

Fig. 7

Operation		
Activity	Display	Function
Actual value = setpoint	Valve and MIN/MAX LEDs are not illuminated.	Valve output contact 16/17/19 open. MIN output contacts 16/18 open, 17/18 closed. MAX output contact 21/23 open, 22/23 closed.

Value above or below setpoint		
Value above or below setpoint.	LED "Valve opens" flashes amber.	Control valve opens, valve output contact 16/19 closed.
	or	
	LED "Valve closes" flashes amber.	Control valve closes, valve output contact 17/19 closed.

MAX alarm		
Water level has reached or exceeds switchpoint MAX.	MAX LED flashes red.	De-energizing delay is running.
	MAX LED illuminated red	Time delay elapsed, output contact 21/23 closed, 22/23 open.
or		
MIN alarm		
Water level has reached or exceeds switchpoint MIN.	MIN LED flashes red.	De-energizing delay is running.
	MIN LED illuminated red	Time delay elapsed, output contact 21/23 closed, 22/23 open.



Note

- The level controller NRR 2-50 features only **one** output contact for signalling a limit. For this reason please establish the desired function (MAX or MIN alarm) via code switch **13**. Fig. 5, 6

Operation, Alarm and Test - continued -

Level controller NRR 2-51, indications

Operation		
Activity	Display	Function
Actual value = setpoint	MIN and MAX LEDs are not illuminated.	MIN output contact 16/18 open, 17/18 closed. MAX output contact 21/23 open, 22/23 closed.

MIN alarm		
Water level has reached or is below switchpoint MIN.	MIN LED flashes red.	De-energizing delay is running.
	MIN LED illuminated red	Time delay elapsed, MIN output contact 16/18 closed, 17/18 open.

MAX alarm		
Water level has reached or exceeds switchpoint MAX.	MAX LED flashes red.	De-energizing delay is running.
	MAX LED illuminated red	Time delay elapsed, MAX output contact 21/23 closed, 22/23 open.

Checking functions of MIN / MAX output contacts

Testing MIN alarm and MAX alarm		
Activity	Display	Function
During operation: Water level between MIN and MAX Select parameter "Test". Press and hold down push-button.	MAX LED flashes red.	De-energizing delay is running.
	MAX LED is illuminated red for 3 sec.	MAX output contact 21/23 closed, 22/23 open.
	MIN and MAX LEDs not illuminated for 1 sec.	MIN output contact 16/18 open, 17/18 open. MAX output contact 21/23 open, 22/23 closed.
	MIN LED flashes red.	De-energizing delay is running.
	MIN LED is illuminated red for 3 sec.	MIN output contact 16/18 closed, 17/18 open.
Test finished, release push-button. Equipment returns to operating mode.	Note: If you continue to hold down the push-button, a new test is started. You can abort the test any moment by releasing the push-button.	
Turn the rotary button until the actual value is shown. If no operation is performed the actual value will be indicated automatically after 30 sec.		



Note

The actual value is shown on the seven-segment display

Troubleshooting

Indication, diagnosis and remedy



Attention

Before carrying out the fault diagnosis please check:

Supply voltage:

Is the equipment supplied with the mains voltage specified on the name plate?

Wiring:

Is the wiring in accordance with the wiring diagram?

Faults indicated by the seven-segment display

Error code	Error	Remedy
E.005	Level electrode defective, measuring voltage < 0.5 VDC	Check level electrode and, if necessary, replace it. Check electrical connection.
	Level transmitter defective, measuring current < 4 mA	Check level transmitter and, if necessary, replace it. Check electrical connection.
E.006	Level electrode defective, measuring voltage > 7 VDC	Check level electrode and, if necessary, replace it. Check electrical connection.
	Level transmitter defective, measuring current > 20 mA	Check level transmitter and, if necessary, replace it. Check electrical connection.
E.012	Beginning and end of measuring range have been switched round.	Re-adjust the measuring range.
E.013	MIN switchpoint above MAX switchpoint	Re-adjust the switchpoints.
In the event of a malfunction a MIN and MAX alarm will be triggered.		



Attention

- Please follow the instructions given in the installation & operating manual for the NRG 21-... , NRG 26-21 and NRG 26-1 for further fault finding and troubleshooting.



Note

If a malfunction occurs in the level controller, MIN and MAX alarms will be triggered and the equipment is restarted.

Should this happen over and over again, replace the equipment with a new one.

Further Notes

Action against high frequency interference

High-frequency interference can be caused by out-of-phase switching operations. Should sporadic failures or malfunctions occur take the following remedial actions in order to suppress interference:

- Provide inductive loads with RC combinations according to manufacturer's specification to ensure interference suppression.
- Make sure that all connecting cables leading to the level electrode or to the level transmitter are segregated and run separately from power cables.
- Increase the distance to sources of interference.
- Check the connection of the screen to the central earthing point (CEP) in the control cabinet.
- HF interference suppression by means of hinged-shell ferrite rings.

Decommissioning / replacing the equipment

- Switch off supply voltage and **cut off power supply** to the equipment.
- Remove the lower and upper terminal strips. **Fig. 8**
 - Insert a screwdriver to the right and left of the arrow markings between the terminal strip and the front frame.
 - Unlock terminal strip on the left and right side. For this purpose move screwdriver in direction of the arrow .
 - Remove the terminal strips.
- Release the white fixing slide at the bottom of the equipment and take the equipment off the supporting rail.

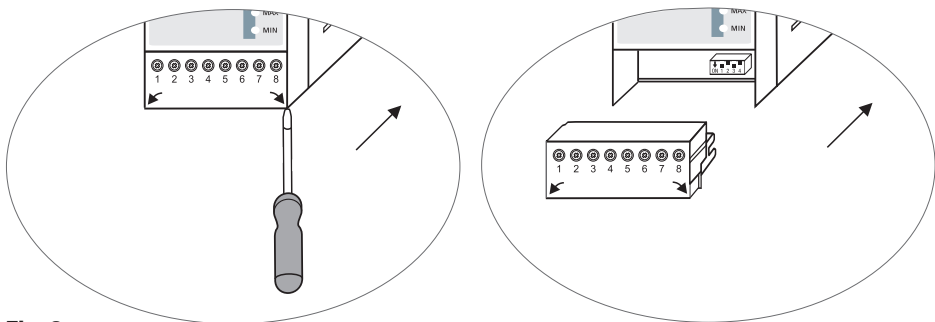

Fig. 8

Disposal

For the disposal of the equipment observe the pertinent legal regulations concerning waste disposal.

If faults occur that are not listed above or cannot be corrected, please contact our service centre or authorized agency in your country.



GESTRA

Agencies all over the world:

www.gestra.de

Great Britain

Flowserve GB Limited

Abex Road
Newbury, Berkshire RG14 5EY
Tel. 0044 16 35 / 46 99 90
Fax 0044 16 35 / 3 60 34
E-Mail gestraukinfo@flowserve.com
Web www.flowserve.com

Singapore

Flowserve Pte. Ltd.

12 Tuas Avenue 20
Singapore 63882
Tel. 0065 / 68 79 89 00
Fax 0065 / 68 62 49 40
E-Mail fcd_gestra_singapore@flowserve.com
Web www.gestra.com

South Africa

Flowserve SA (Pty) Ltd.

Unit No. 1
Director Road
Spartan Extension 2
Kempton Park 1613
Tel. 0027 11 / 9 23 73 00
Fax 0027 11 / 9 74 64 20
E-Mail tvniekerk@flowserve.com
Web www.flowserve.com

USA

Flowserve GESTRA U.S.

2341 Ampere Drive
Louisville, KY 40299
Tel. 001 502 / 267-22 05
Fax 001 502 / 266-53 97
E-Mail fcd-gestra-usa@flowserve.com

GESTRA AG

P. O. Box 10 54 60, D-28054 Bremen
Münchener Str. 77, D-28215 Bremen
Tel. 0049 (0) 421 35 03 - 0
Fax 0049 (0) 421 35 03 - 393
E-Mail gestra.ag@flowserve.com
Web www.gestra.de

