



FLOWSERVE

GESTRA

GESTRA Steam Systems

NRG 26-21

EN

English

Installation Instructions 818774-02

Level Electrode
NRG 26-21

Contents

Page

Important Notes

Usage for the intended purpose	4
Safety note	4
Danger	4
Attention	4
ATEX (Atmosphère Explosible).....	4
Note on the Declaration of Conformity / Declaration by the Manufacturer CE	4

Explanatory Notes

Scope of supply	5
System description	5
Function	5
Design	5

Technical Data

NRG 26-21	6, 7
Name plate / marking	7
Dimensions.....	8

Design

NRG 26-21	9
Key	11

Functional Elements

NRG 26-21	10
Key	11

Installation

NRG 26-21	12
Attention	12
Note	12
Tools.....	12
Examples of installation	13
Key	14

Contents – continued –

Page

Electrical Connection

NRG 26-21	15
Wiring diagram	16
Setting measuring range.....	16
Tools.....	16

Basic Settings

Factory setting.....	17
Establishing active measuring range.....	17 – 19
Attention.....	17
Note	20

Commissioning

Checking electrical connection	20
Checking measuring voltages	20

Operation

NRG 26-21	20
Note	20

Operational Malfunctions

Fault-finding list for troubleshooting.....	21
---	----

Decommissioning

Danger	22
Disposal.....	22

Important Notes

Usage for the intended purpose

Use level electrode NRG 26-21 only in conjunction with level switches NRR 2..., NRS 2... or NRT 2... for indicating liquid levels.

Note that the equipment must **not** be used in explosion risk areas.

Safety note

The equipment must only be installed and commissioned by qualified and adequately trained personnel.

Maintenance and retrofitting must only be performed by entrusted personnel who – through adequate training – have achieved a recognised level of competence.



Danger

When loosening the electrode live steam or hot water might escape.

This presents the danger of severe scalding.

It is therefore essential not to dismantle the electrode unless the boiler pressure is verified to be zero.

The electrode is hot during operation.

This presents the risk of severe burns to hands and arms.

Installation and maintenance work should only be carried out when the system is cold.



Attention

The name plate specifies the technical features of the equipment. Note that any piece of equipment without its specific name plate must neither be commissioned nor operated.

ATEX (Atmosphere Explosible)

According to the European Directive 94/9/EC the equipment must **not** be used in potentially explosive areas.

Note on the Declaration of Conformity / Declaration by the Manufacturer

For details on the conformity of our equipment according to the European Directives see our Declaration of Conformity or our Declaration of Manufacturer.

The current Declaration of Conformity / Declaration of Manufacturer are available in the Internet under www.gestra.de/documents or can be requested from us.

Explanatory Notes

Scope of supply

NRG 26-21

- 1 Level electrode NRG 26-21 with joint ring D 27 x 32 DIN 7603, 1.4301 bright annealed
- 1 Installation manual

System description

The level electrode NRG 26-21 works according to the capacitance measurement principle. The NRG 26-21 is used for signalling different levels in electrically conductive and non-conductive liquids:

- Levels maintained within the control band defined by two preset limits

The preamplifier NRV 2-29 is integrated in the terminal box of the level electrode.

Function

The principle of capacitance measurement is applied to determine the level. The electrode rod and the vessel wall form a capacitor. If the level of the dielectric located between the two capacitor plates changes, the current which flows through the plates changes proportionally to the level.

A dielectric is defined as an insulating substance, which excludes many liquids such as water. In order to receive a useful measuring result the measuring rod, which is submerged to varying depths in the liquid, must be completely insulated. After the calibration of the zero point / measuring range (0 % / 100 %), the level can be read off from a remote display unit. The level measuring range can be changed during operation.

Design

NRG 26-21

Screwed design $\frac{3}{4}$ ", DIN ISO 228-1, **Fig. 2**

Technical Data

NRG 26-21

Type approval no.

TÜV · WR · 01-320

Service pressure

PN 40, 32 barg at 238 °C

Connections

Screwed ¾", DIN ISO 228-1

Materials

Terminal box: PPO (Noryl®)

Sheath: 1.4301 X5 CrNi18-10

Screwed union: 1.4571 CrNiMoTi17-12-2

Measuring electrode: 1.4571 CrNiMoTi17-12-2

Electrode insulation: PTFE

Supply voltage

12 V

Length supplied / measuring range

14 Max. installation length at 238 °C

15 Measuring range

14	15
373	300
477	400
583	500
688	600
794	700
899	800
1004	900
1110	1000
1214	1100
1319	1200
1423	1300
1528	1400
1636	1500
2156	2000

Technical Data – continued –

NRG 26-21 – continued –

Sensitivity

Range 1: Water $\geq 0.5 \mu\text{S/cm}$

Range 2: Water $\geq 20 \mu\text{S/cm}$

Range 3: Fuel oil EL $\epsilon_r 2.3$

Cable entry

Cable gland with integral cable clamp M 16

Protection

IP 65 to DIN EN 60529

Max. admissible ambient temperature

70 °C

Weight

approx. 1.8 kg

Name plate / marking





Equipment designation			Safety note				
NRG 26-21				Betriebsanleitung beachten See installation instructions Voir instructions de montage			Disposal note
PN 40	G 3/4	1.4571	IP 65	TÜV.WR/WRS.09-317	TÜV.WR.06-320		Pressure rating, thread type, material number, type approval number
	32 bar (464psi) 238°C (460°F) T amb = 70°C (158 °F)						CE marking
GESTRA AG		• D-28215 Bremen	Mat.Nr.:				
Manufacturer			Material number				

Fig. 1

Dimensions

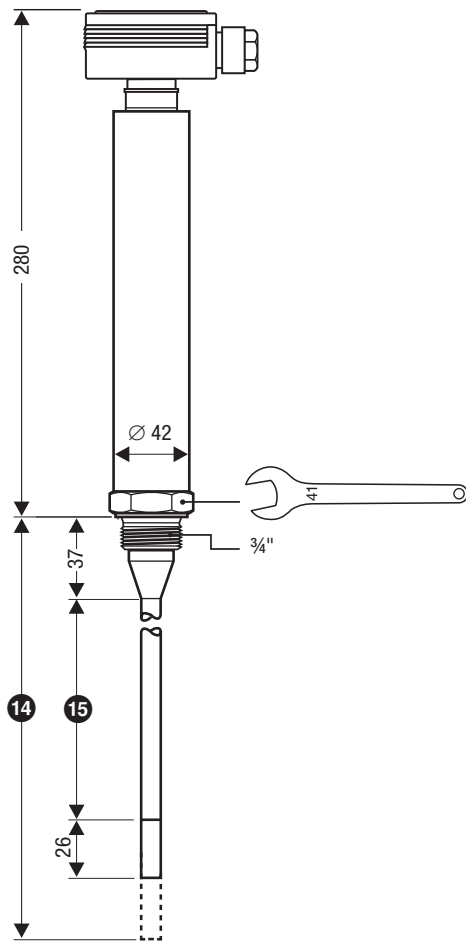

Fig. 2

15 Constant length (no elongation)

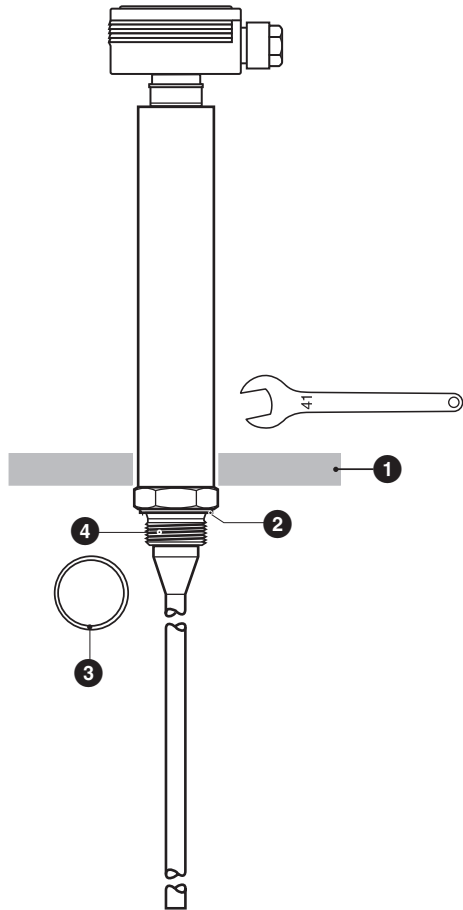

Fig. 3

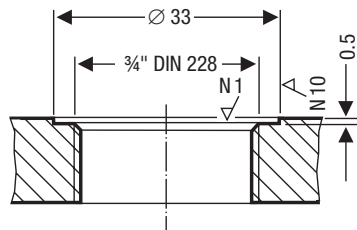

Fig. 4

Functional Elements

NRG 26-21

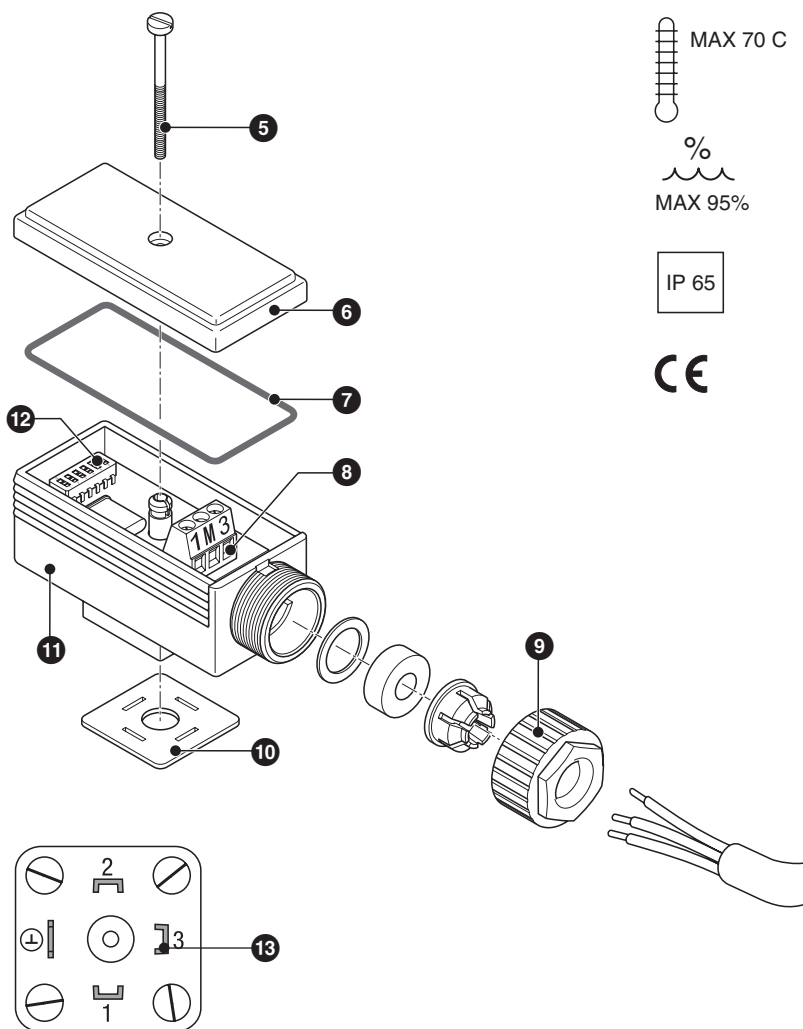

Fig. 5

Preamplifier NRV 2-29 integrated in the terminal box

Design / Functional Elements

Key

- 1 Thermal insulation provided on site, d = 20 mm (without thermal insulation of steam boiler)
- 2 Seating surface
- 3 Joint ring D 27 x 32, DIN 7603 – 1.4301
- 4 Electrode thread $\frac{3}{4}$ ", DIN ISO 228-1
- 5 Screw M4
- 6 Cover
- 7 Seal
- 8 Terminal strip
- 9 Cable entry M16 (PG 9)
- 10 Sealing plate
- 11 Terminal box (with preamplifier NRV 2-29)
- 12 Code switch
- 13 Contact plate
- 14 Max. installation length at 238 °C
- 15 Measuring range

Installation

NRG 26-21

1. Check seating surfaces of threads or flange provided on vessel or boiler standpipe, **Fig. 4**.
2. Place joint ring ③ onto seating surface ② of the electrode, **Fig. 3**.
Use only joint ring (of stainless steel 1.4301) D 27 x 32 to DIN 7603 supplied with electrode.
3. Apply a light smear of silicone grease (e. g. DOW Corning 111 Compound) to electrode thread ④.
4. Screw level electrode into threads or flange provided on vessel or boiler standpipe and tighten with a 41 mm open-end spanner. The torque required for tightening is **160 Nm** when cold.



Attention

- The seating surface of the threads and flanges provided on the vessel or boiler standpipe must be accurately machined, **Fig. 4**.
- Do not bend electrode rod when mounting.
- Do not lag electrode body.
- Do not insulate electrode thread with hemp or PTFE tape.



Note

- For the approval of the boiler standpipe with connecting flange the relevant local or national regulations must be considered.
- See four examples of installation of page 13.

Tools

- Open-end spanner 41 mm A. F.

Examples of installation

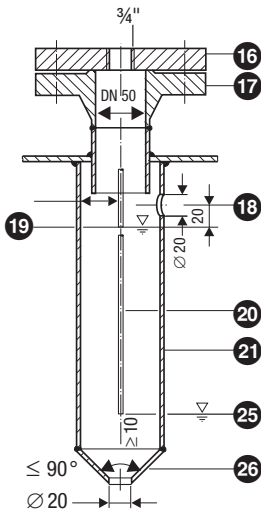

Fig. 6

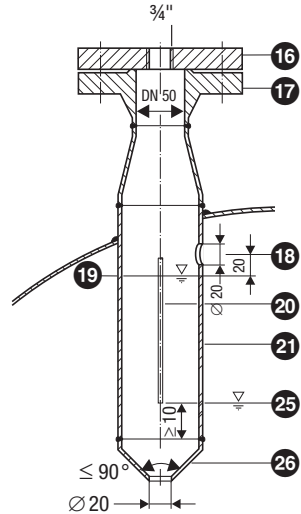

Fig. 7

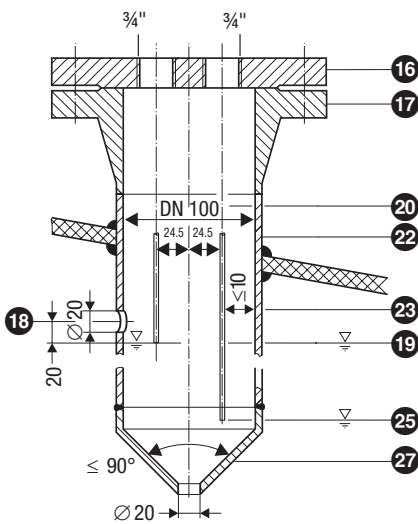

Fig. 8

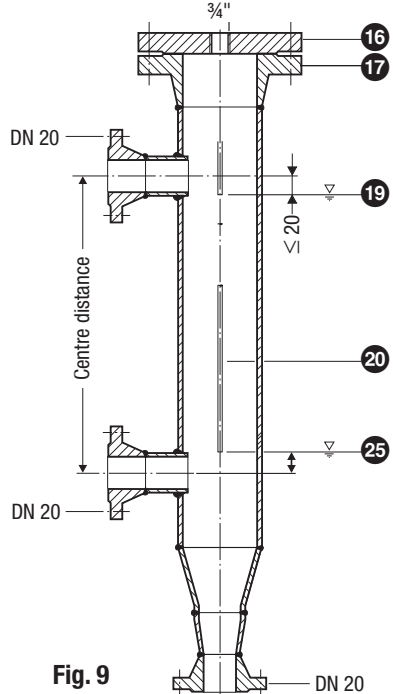

Fig. 9

Key

- 16 Flange PN 40, DN 50, DIN 2527
Flange PN 40, DN 100, DIN 2527
- 17 For the approval of the boiler standpipe with connecting flange the relevant regulations must be considered.
- 18 Vent hole
- 19 High water (HW)
- 20 Electrode rod $d = 15 \text{ mm}$
- 21 Protection tube DN 80
- 22 Protection tube DN 100
- 23 Electrode distance $\geq 14 \text{ mm}$ (LW)
- 24 Electrode distance $\geq 40 \text{ mm}$ (LW)
- 25 Low water (LW)
- 26 Reducer DIN 2616-2, part 2 K-88.9 x 3.2 - 42.4 x 2.6 W
- 27 Reducer DIN 2616-2, part 2 K-114.3 x 3.6 - 48.3 x 2.9 W

Electrical Connection

NRG 26-21

Electrical connection via four pole connector.

Note that screened four core cable, e. g. I-Y(St)Y 2 x 2 x 0.8 or LICYC 4 x 0.5 mm² is required for wiring the electrode.

Max. length 100 m with conductivities from 10 µS/cm.

Max. length 30 m with conductivities from 0.5 µS/cm.

1. Undo screw ⑤, Fig. 5.
2. Take the terminal box off the level electrode, leaving the sealing plate ⑩ on the contact plate ⑬.
3. Remove cover ⑥ with seal ⑦.
4. Detach cable gland ⑨ from terminal box ⑪.
5. Run cable through cable gland ⑨ of the terminal box ⑪ and connect the terminals of the terminal strip ⑧ according to the wiring diagram.
6. Replace cover ⑥ and insert screw ⑤.
7. Put terminal box onto the level electrode and fix it firmly by tighten screw ⑤.

Wiring diagram

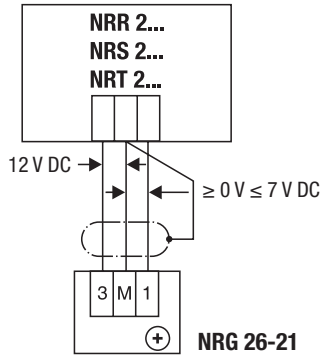

Fig. 10

Setting measuring range

Adjust the preamplifier NRV 2-26 integrated in the terminal box **11** to the operating conditions prevailing in your installation before putting the level electrode into operation. Make sure that the measuring range setting is correct for your application and check whether the fluid to be controlled is electrically conductive or not before commissioning the electrode.

Tools

- Screwdriver for cross-recess head screws, size 1
- Screwdriver for slotted screws, size 2.5, completely insulated to VDE 0680
- Open-end spanner 17 mm A. F.

Basic Settings

Factory setting

The default setting of the code switch 12 is the max. measuring range for water (conductivity $\geq 20 \mu\text{S}/\text{cm}$). The max. measuring range is the length 15 (distance between lower and upper measuring point) plus 26 mm, see Fig. 11.

The level electrode features the following factory set default values:

- Measuring range up to 350 mm: Code switch 12 position 4, 5 ON, 1, 2, 3, 6 OFF
- Measuring range 350 mm to 750 mm: Code switch 12 position 4 ON, 1, 2, 3, 5, 6 OFF
- Measuring range 750 mm to 1500 mm: Code switch 12 position 3 ON, 1, 2, 4, 5, 6 OFF
- Measuring range 1500 mm to 2500 mm: Code switch 12 position 2 ON, 1, 3, 4, 5, 6 OFF

Establishing active measuring range

A control range may be established within the measuring range of the electrode. Establish the length of the control range using the code switch 12, see Fig. 5, Fig. 11

- ⊗ Selected control range (= active measuring range) in [mm]
- 15 Max. measuring range at 25 °C
- 28 Diagram for water, conductivity $\geq 20 \mu\text{S}/\text{cm}$
- 29 Diagram for water, conductivity $\geq 5 \mu\text{S}/\text{cm}$
- 30 Diagram for fuel oil EL, dielectric constant $\epsilon_r 2.3$

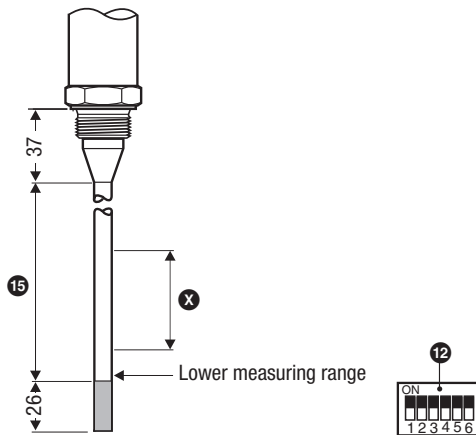

Fig. 11



Attention

- If ⊗ is clearly smaller than 15 change the code switch according to the diagrams 28, 29 and 30 to adapt the setting to the fluid used in the installation.

Establishing active measuring range – continued –

Ascertain the type of fluid to be monitored. Establish the active measuring range [mm] for your application. Use diagrams 28, 29 or 30 to determine the required code switch settings for water and fuel oil EL.

Example: Max. measuring range at 25 °C: 1500 mm, active measuring range: 1000 mm, switch 3 of the code switch must be set to ON and all other switches to OFF.

If the fluid to be monitored is not water or fuel oil EL, the voltage must be measured in order to determine the switch position. For this purpose switch on the mains switch of the associated level switch NRR 2..., NRS 2... or NRT 2... .

1. Open the cover 6 of the terminal box 11.
2. Fill vessel until its max. liquid level is reached and then connect a voltmeter between the terminals "1" (+) and "M" (-). Before starting the measurement set all switches of the code switch to OFF.
3. Now operate each individual switch in turn: first only 1 to ON, then only 2 to ON, then only 3 to ON, then only 4 to ON, then 4 + 5 to ON and then 4 + 5 + 6 to ON. As soon as with one of the switch positions the value measured by the voltmeter exceeds 7 V, select the preceding switch position.
4. After having set the code switch, put cover 6 onto the terminal box 11 and fix it by fastening the screw 5.

28 Diagram for water, conductivity $\geq 20 \mu\text{S/cm}$

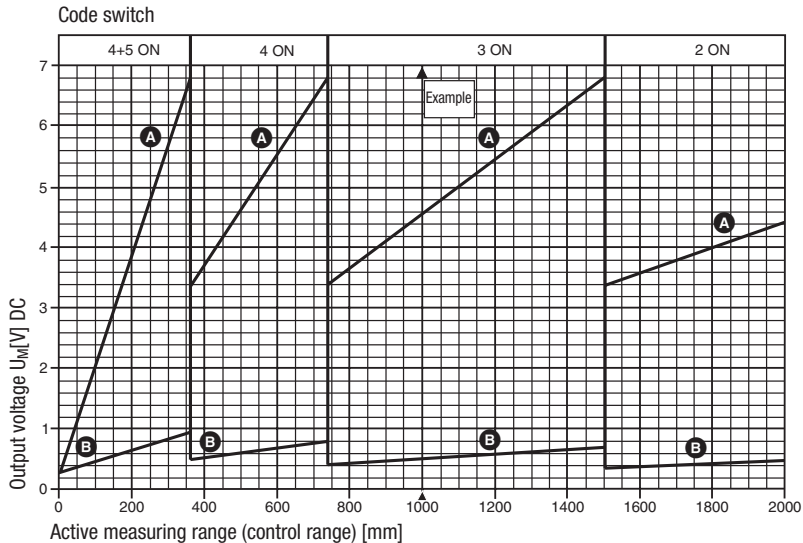

Fig. 12

- A = completely submerged
- B = completely exposed

Establishing active measuring range – continued –

29 Diagram for water, conductivity $\geq 25 \mu\text{S/cm}$

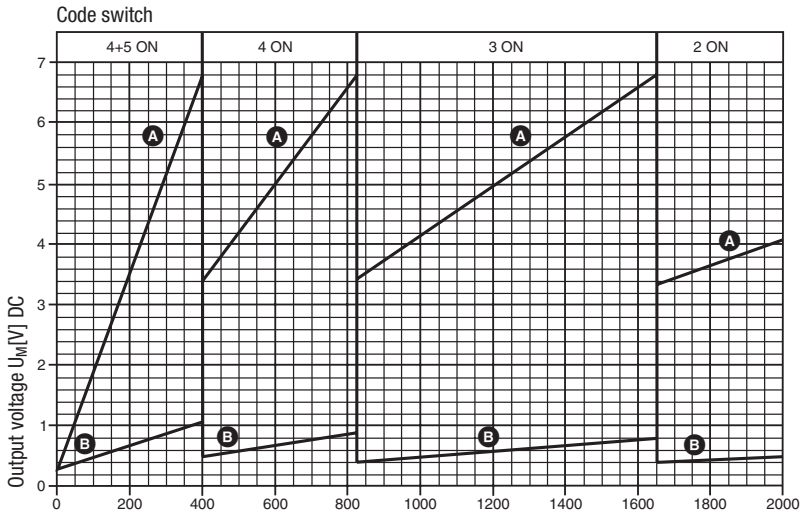

Fig. 13

Active measuring range (control range) [mm]

- A** = completely submerged
- B** = completely exposed

30 Diagram for fuel oil EL, dielectric constant ϵ_r 2.3

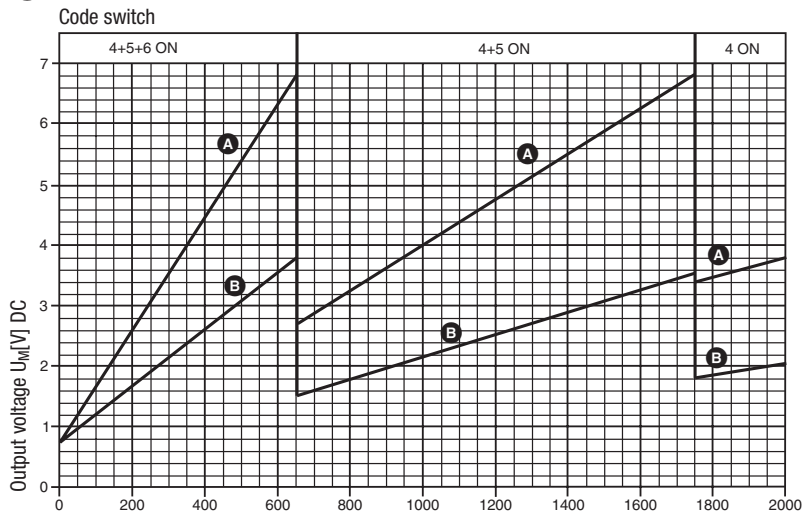

Fig. 14

Active measuring range (control range) [mm]

- A** = completely submerged
- B** = completely exposed

Basic Settings – continued –



Note

- When the measuring points of the electrode are established when the equipment is **cold**, the measuring points will shift as the temperature increases due to the thermal expansion of the electrode rod. The setting must then be corrected.

Commissioning

Checking electrical connection

1. Make sure that the system NRG 26-21 is wired according to the wiring diagram, **Fig. 10**.
2. Make sure that the mains voltage of the associated level switch agrees with the ratings on the name plate.

Checking measuring voltages

The supply voltage of the electrode can be measured between terminals “3” and “M” in the terminal box **11**. The voltage should be 12 V d. c. If this voltage is not measured, the electrode has to be checked at our works or by a works official.

The level-proportional voltage U_M can be measured between terminals “1” (+) and “M” (-). Raise the liquid level in the vessel to the max. point of the control range (completely submerged), e. g. 1000 mm, and measure the voltage.

Compare the value measured with the value of the corresponding diagram (in chart **28**, U_M for 1000 mm is 4.6 V). The following values must be obtained in any case:

Level electrode completely exposed: $U_M \geq 0$ V, level electrode completely submerged: $U_M \leq 7$ V.

If the level electrode is submerged and $U_M = 0$ V or $U_M > 7$ V is measured, the level electrode has to be checked in our service department.

Operation

NRG 26-21

Operation in steam and (pressurised) hot water plants in accordance with TRD 401, TRD 602, TRD 604, EN 12952; EN 12953 or other national regulations or according to the guidelines of classification societies.



Note

- Should malfunctions occur during the commissioning procedure refer to chapter “Operational Malfunctions” on page 21 in order to analyse and correct them.

Operational Malfunctions

Fault-finding list for troubleshooting

The equipment fails to work

Fault: The electrode housing does not have earth connection to the boiler.
Remedy: Clean seating surfaces and insert metal joint ring as shown in drawing.
Do **not** insulate the electrode with hemp or PTFE tape.

Fault: Mains voltage is not applied to the equipment.
Remedy: Apply mains voltage. Wire equipment according to the wiring diagram.

The equipment does not work properly

Fault: The vent hole in the protection tube does not exist, is obstructed or flooded.
Remedy: Check protection tube and, if necessary, provide vent hole.

Fault: The isolating valves of the external measuring pot are closed.
Remedy: Open the isolating valves.

Fault: The electrode has been installed without a protection tube.
The protection tube serves as reference electrode.
Remedy: Install a protection.

Fault: The desired zero point does not lie within the measuring range of the electrode.
The electrode is too short.
Remedy: Replace the electrode. Choose correct electrode length.

Fault: Dirt deposits have accumulated on the electrode rod.
Remedy: Remove the electrode and clean its rod with a wet cloth.

Fault: The adjustment of the measuring range is incorrect.
Remedy: Correct the code switch  setting, see section "Basic Settings".

If faults occur that are not listed above, please contact our subsidiary or agency in your country.

Decommissioning



Danger

Risk of severe burns and scalds to the whole body!
Before removing the level electrode make sure that the vessel or measuring pot are depressurised (0 bar) and cooled down to room temperature (20 °C).

Disposal

Remove the level electrode and separate the waste materials in accordance with the material specification. Electronic components (circuit boards) must be disposed of separately.
For the disposal of the level electrode observe the pertinent legal regulations concerning waste disposal.

For your notes



GESTRA

Agencies all over the world:

www.gestra.de

España

GESTRA ESPAÑOLA S.A.

Luis Cabrera, 86-88

E-28002 Madrid

Tel. 0034 91 / 5 15 20 32

Fax 0034 91 / 4 13 67 47; 5 15 20 36

E-mail: aromero@flowserve.com

Polska

GESTRA POLONIA Spolka z.o.o.

Ul. Schuberta 104

PL - 80-172 Gdansk

Tel. 0048 58 / 3 06 10 - 02

0048 58 / 3 06 10 - 10

Fax 0048 58 / 3 06 33 00

E-mail: gestra@gestra.pl

Great Britain

Flowserve GB Limited

Abex Road

Newbury, Berkshire RG14 5EY

Tel. 0044 16 35 / 46 99 90

Fax 0044 16 35 / 3 60 34

E-mail: gestraukinfo@flowserve.com

Portugal

Flowserve Portuguesa, Lda.

Av. Dr. Antunes Guimarães, 1159

Porto 4100-082

Tel. 00351 22 / 6 19 87 70

Fax 00351 22 / 6 10 75 75

E-mail: jtavares@flowserve.com

Italia

Flowserve S.p.A.

Flow Control Division

Via Prealpi, 30

I-20032 Cormano (MI)

Tel. 0039 02 / 66 32 51

Fax 0039 02 / 66 32 55 60

E-mail: infoitaly@flowserve.com

USA

Flowserve GESTRA U.S.

2341 Ampere Drive

Louisville, KY 40299

Tel. 001 502 / 267-2205

Fax 001 502 / 266-5397

E-mail: FCD-Gestra-USA@flowserve.com

GESTRA AG

P. O. Box 10 54 60, D-28054 Bremen

Münchener Str. 77, D-28215 Bremen

Telephone 0049 (0) 421 35 03 - 0

Fax 0049 (0) 421 35 03 - 393

E-Mail gestra.ag@flowserve.com

Internet www.gestra.de

