

GESTRA Steam Systems

NRG 16-50

NRG 17-50

NRG 19-50

NRG 111-50

EN

English

Installation Instructions 818954-01

Level Electrodes

NRG 16-50, NRG 17-50, NRG 19-50,

NRG 111-50

Contents

Page

Application

Usage for the intended purpose	4
Function	4

Directives and Standards

Pressure Equipment Directive (PED) 97/23/EC	5
Functional Safety acc. to IEC 61508	5
VdTÜV Bulletin "Wasserstand 100" (= Water Level 100).....	5
ATEX (Atmosphère Explosible).....	5

Technical Data

NRG 16-50, NRG 17-50, NRG 19-50, NRG 111-50	6
Corrosion resistance	7
Sizing	7
Name plate / marking	8
Dimensions NRG 16-50, NRG 17-50, NRG 19-50	9
Dimensions NRG 111-50	10

Functional Elements

NRG 16-50, NRG 17-50, NRG 19-50	11
NRG 16-50, NRG 17-50, NRG 19-50, NRG 111-50 four-pole connector	11,12
NRG 16-50F, NRG 17-50F, NRG 19-50F, NRG 111-50F aluminium terminal box	13
Key	14

Important Notes

Safety note	15
Scope of supply	15

Installation

NRG 16-50, NRG 17-50, NRG 19-50, NRG 111-50, step 1	16
NRG 16-50, NRG 17-50, NRG 19-50, NRG 111-50, step 2	16
NRG 16-50F, NRG 17-50F, NRG 19-50F, additional information	16
Tools	17

Examples of installation

NRG 16-50, NRG 17-50, NRG 19-50	18
NRG 111-50	19
Key	20

Contents – continued –

Page

Electrical Connection

Connection of level electrode	21
NRG 16-50, NRG 17-50, NRG 19-50, NRG 111-50, with four-pole connector	21
NRG 16-50F, NRG 17-50F, NRG 19-50F, NRG 111-50F, with aluminium terminal box	21
Wiring diagram	22
Key	23
Tools	23

Commissioning, fault indication and remedy

NRG 16-50, NRG 17-50, NRG 19-50, NRG 111-50	23
---	----

Decommissioning

Disposal	23
----------------	----

Application

Usage for the intended purpose

The level electrodes NRG 16-50, NRG 17-50, NRG 19-50 and NRG 111-50 are used in conjunction with level switch NRS 1-50 as water level limiters for steam boiler plants and (pressurised) hot water installations.

Water level limiters switch off the heating when the water level falls below the set minimum level (low water).

Function

When the water level falls below the low level, the level electrode is exposed and a low level alarm is triggered in the level switch NRS 1-50. This switchpoint "Low water level (LW)" is determined by the length of the electrode tip.

The self-monitoring function ensures that an alarm will also be triggered if the electrode insulation is contaminated or has developed a leak or if there is a malfunction in the electrical connection.

The level electrode is installed inside steam boilers, vessels or inlet lines of hot-water systems. The protective tube mounted on site (see section **Examples of Installation** (pages 18, 19) ensures correct functioning.

One level electrode NRG 1...-50 can be installed together with one GESTRA level electrode, one level switch or transmitter for water level control and high level alarm in one single protection tube or level pot.

If the level electrode is installed in an isolatable level pot outside the boiler, make sure that the connecting lines are rinsed regularly. In addition, the logic unit SRL is required to monitor the purging times and the purging sequence.

If the connecting lines for steam ≥ 40 mm and water ≥ 100 mm, the installation is considered to be internal. In this case the rinsing processes do not have to be monitored.

Directives and Standards

Pressure Equipment Directive (PED) 97/23/EC

Water level limiters are safety accessories as defined in the Pressure Equipment Directive (PED). The level electrode NRG 1...-50 in conjunction with level switch NRS 1-50 is EC type approved according to EN 12952/EN 12953. These Directives state, among other things, the requirements made on limiting systems and equipment for steam boiler plants and (pressurised) hot-water installations.

Functional Safety acc. to IEC 61508

The level electrodes NRG 1...-50 / NRG 16-36 are certified acc. to IEC 61508 only if used in combination with level switch NRS 1-50.

This standard describes the functional safety of safety-related electrical/electronic/programmable electronic systems.

The equipment combination NRG 1...-50 or NRG 16-36 + NRS 1-50 corresponds to a type B subsystem with Safety Integrity Level (SIL) 3.

VdTÜV Bulletin "Wasserstand 100" (= Water Level 100)

The level electrodes NRG 1-50, NRG 1...-11 and NRG 16-36 in conjunction with the level switch NRS 1-50 are type approved according to the VdTÜV Bulletin "Water Level 100".

The VdTÜV Bulletin "Wasserstand (=Water Level) 100" specifies the requirements made on water level control and limiting equipment for boilers.

ATEX (Atmosphère Explosible)

The level electrodes NRG 1...-50, NRG 1...-11 and NRG 16-36 are simple items of electrical equipment as specified in EN 60079-11 section 5.7. According to the European Directive 94/9/EC the equipment must be equipped with approved Zener barriers if used in potentially explosive areas. Applicable in Ex zones 1, 2 (1999/92/EC). The equipment does not bear an Ex marking.

The suitability of the Zener barriers is certified in a separate document.

Note that the requirements of the IEC 61508 are not met if the NRG 1...-50, NRG 1...-11, NRG 16-36 + Zener barriers + NRS 1-50 are interconnected!

Technical Data

NRG 16-50, NRG 17-50, NRG 19-50, NRG 111-50

Service pressure

NRG 16-50: PN 40, 32 bar at 238 °C

NRG 17-50: PN 63, 60 bar at 275 °C

NRG 19-50: PN 160, 100 bar at 311 °C

NRG 111-50: PN 320, 183 bar at 357 °C

Mechanical connection

Screwed ¾" to EN ISO 228-1 (NRG 16-50, NRG 17-50, NRG 19-50)

Screwed 1" to EN ISO 228-1 (NRG 111-50)

Materials

Sheath: 1.4301, X5 CrNi18-10

Screw-in body: 1.4571, X6CrNiMoTi17-12-2 (NRG 16-50, NRG 17-50, NRG 19-50)

Screw-in body: 1.4529, X1NiCrMoCuN25-20-7 (NRG 111-50)

Measuring electrode: 1.4571, X6CrNiMoTi17-12-2 (NRG 16-50, NRG 17-50, NRG 19-50)

Measuring electrode: 1.4122, X39CrMo17-1 (NRG 111-50)

Electrode tip: 1.4401, X5CrNiMo17-12-2

Electrode insulation: Gylon® (NRG 16-50, NRG 17-50, NRG 19-50)

Electrode insulation: Special ceramic (NRG 111-50)

NRG 1...-50: Four-pole connector: polyamid (PA)

NRG 1...-50F: Terminal box 3.2161 G AISi8Cu3

Lengths supplied

500 mm, 1000 mm, 1500 mm, 2000 mm, 2500 mm, 3000 mm

ph value

Max. admissible: 10 (NRG 111-50)

Electrical connection

NRG 1...-50: Four-pole connector, cable glands M 16

NRG 1...-50F: Terminal box made from aluminium, cable gland M 20

Protection

IP 65 to EN 60529

Max. admissible ambient temperature

70°C

Weight

Approx. 1.2 kg (without extension) (NRG 16-50, NRG 17-50, NRG 19-50)

Approx. 2.1 kg (without extension) (NRG 16-50F, NRG 17-50F, NRG 19-50F)

Approx. 1.8 kg (without extension) (NRG 111-50)

Approx. 2.7 kg (without extension) (NRG 111-50F)

Approvals

EC Prototype approval PED Pressure Equipment Directive 97/23/EC, EN 12952-11, EN 12953-09:
Requirements made on limiting equipment for boilers.

Functional Safety SIL 3 IEC 61508:
Functional safety of safety-related electrical/electronic/programmable
electronic systems

TÜV type approval VdTÜV Bulletin "Wasserstand 100" (= Water Level 100):
Requirements made on water level limiting & control equipment.
Type approval no. TÜV · SWB / SHWS · XX-XXX
(see name plate)

Technical Data – continued –





Corrosion resistance

If the equipment is used for the intended purpose, its safety is not impaired by corrosion.

Sizing

The body is not designed for pulsating loads. Welds and flanges are designed to withstand dynamic loading (bending and alternative stress). The dimensional allowances and anti-corrosive additives reflect the latest state of the technical art.

Name plate / marking

Equipment designation			Safety note			
NRG 16-50 			 Betriebsanleitung beachten See installation instructions Voir instructions de montage			 Disposal note
PN 40	G 3/4	1.4571 IP 65	TÜV . SWB/SHWS . 09-...			 CE 0525
 32 bar (464psi) 238°C (460°F) T amb = 70°C (158 °F)						
GESTRA AG • D-28215 Bremen			Serial number			





NRG 111-50 			 Betriebsanleitung beachten See installation instructions Voir instructions de montage			
G 1	1.4529	IP 65	TÜV . SWB/SHWS . 09-...			 CE 0525
 180 bar (2609psi) 357°C (675°F) T amb = 70°C (158 °F)						
GESTRA AG • D-28215 Bremen			Manufacturer			

Fig. 1











 Betriebsanleitung beachten See installation instructions Voir instructions de montage Hier öffnen Open here Ouvrir ici			 Betriebsanleitung beachten See installation instructions Voir instructions de montage Hier öffnen Open here Ouvrir ici			Safety note
NRG 16 - 50 F PN 40 <input type="checkbox"/>			NRG 111 - 50 F			Equipment designation
NRG 17 - 50 F PN 63 <input type="checkbox"/>			G 1 1.4529 IP65			Pressure rating, thread type, material number
NRG 19 - 50 F PN160 <input type="checkbox"/>			 180 bar (2609psi) 357°C (675°F)			Pressure/temperature rating
G 3/4 1.4571 IP65			 Tamb = 70°C (158 °F)			
 32 bar (464psi) 238°C (460°F)			TÜV . SWB/SHWS . 09-...			 CE 0525 CE Marking, type approval
 60 bar (870psi) 275°C (527°F)			GESTRA AG Münchener Str. 77 D-28215 Bremen			
 100 bar (1450psi) 311°C (592°F)			 Disposal note			
 Tamb = 70°C (158°F)			Manufacturer			
GESTRA AG Münchener Str. 77 D-28215 Bremen			Serial number			

Fig. 2

Fig. 3

Dimensions NRG 16-50, NRG 17-50, NRG 19-50

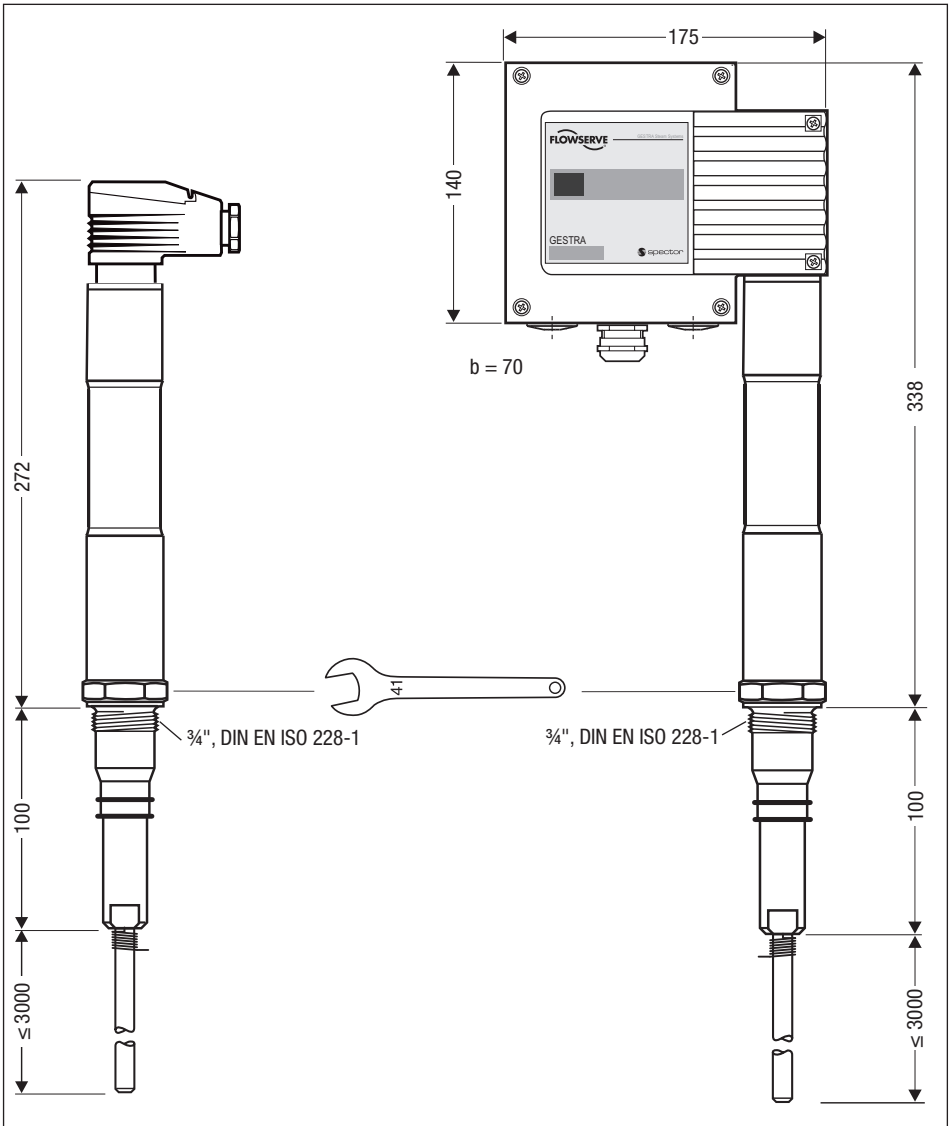

Fig. 4

NRG 16-50, NRG 17-50, NRG 19-50
with four-pole connector

Fig. 5

NRG 16-50F, NRG 17-50F, NRG 19-50F
with aluminium terminal box

Dimensions NRG 111-50

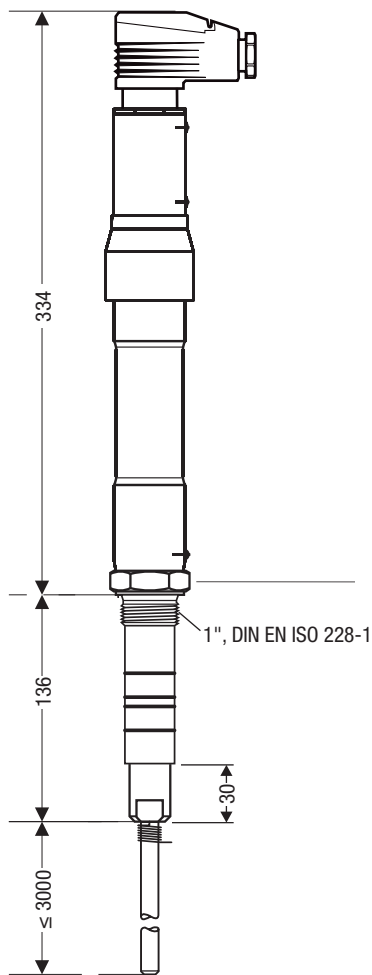

Fig. 6
NRG 111-50

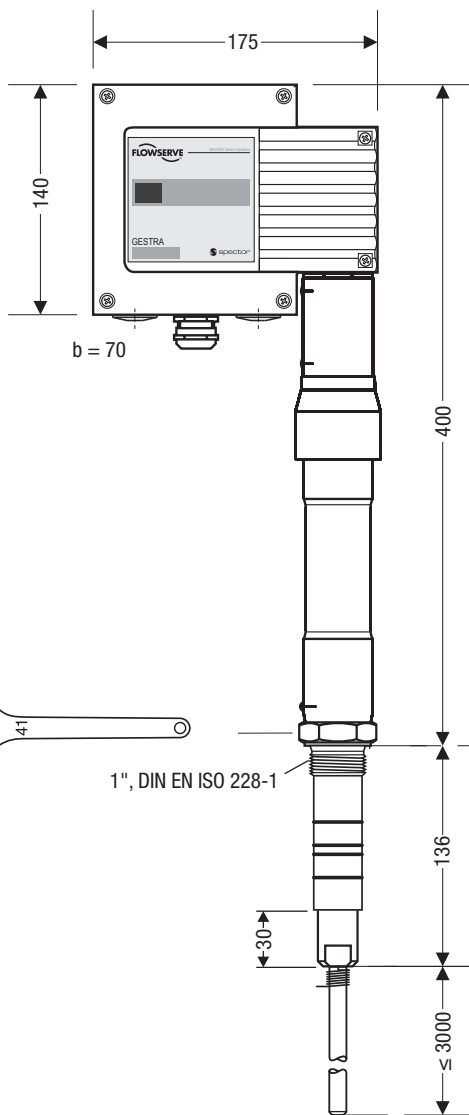

Fig. 7
NRG 111-50F

Functional Elements

NRG 16-50, NRG 17-50, NRG 19-50, NRG 111-50

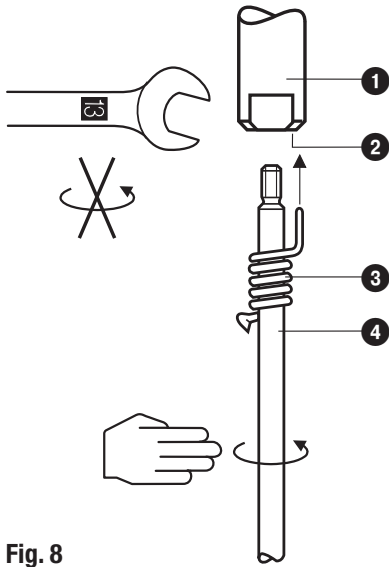

Fig. 8

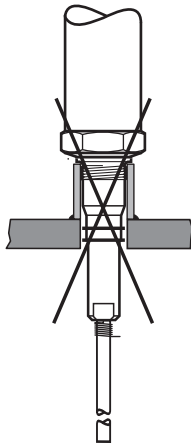

Fig. 10

NRG 16-50
NRG 17-50
NRG 19-50

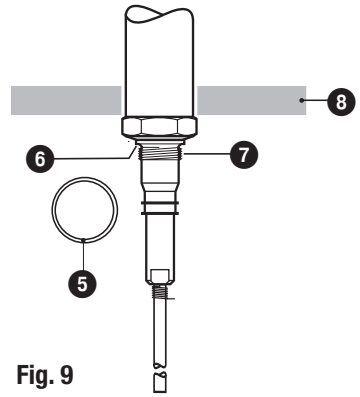

Fig. 9

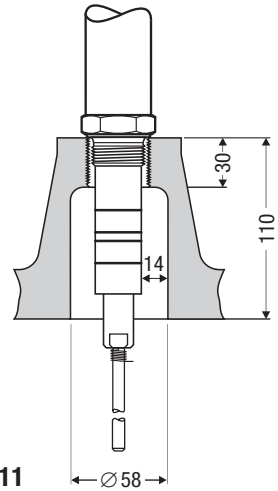

Fig. 11

NRG 111-50

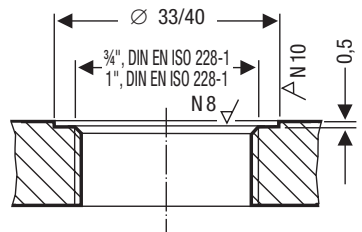
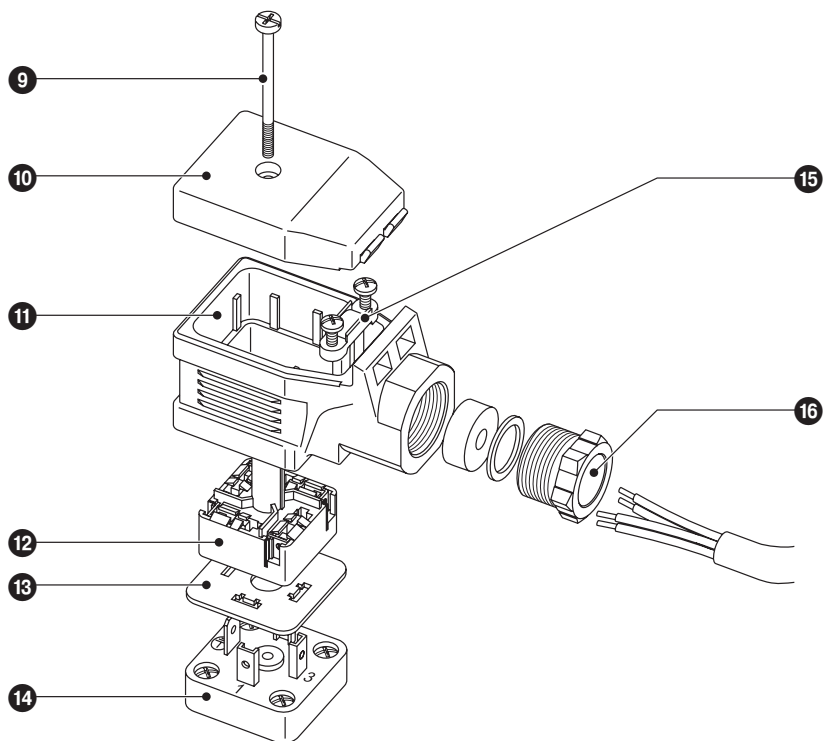



Fig. 12

NRG 16-50, NRG 17-50, NRG 19-50, NRG 111-50 four-pole connector



 MAX 70°C

MAX 95%

IP 65

Fig. 13



NRG 16-50F, NRG 17-50F, NRG 19-50F, NRG 111-50F aluminium terminal box

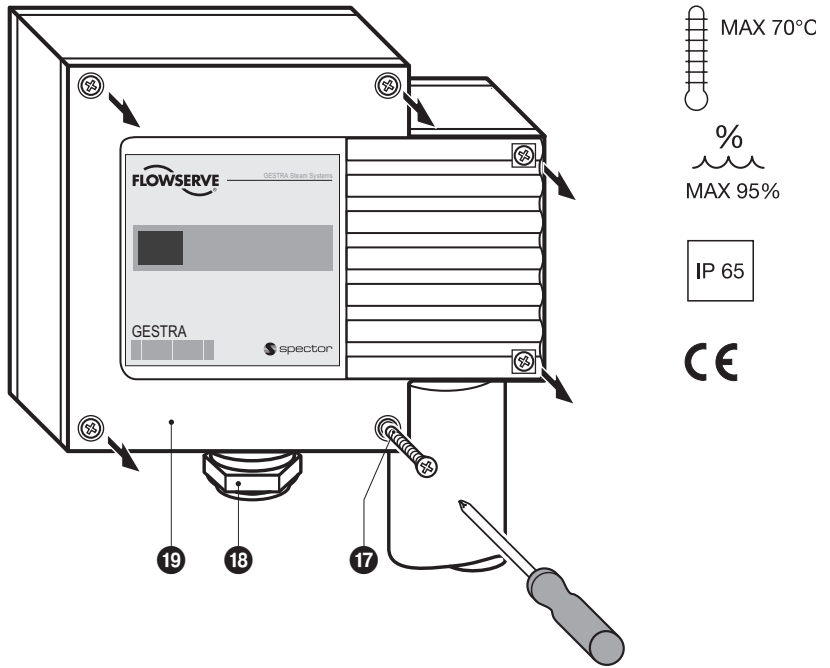

Fig. 14

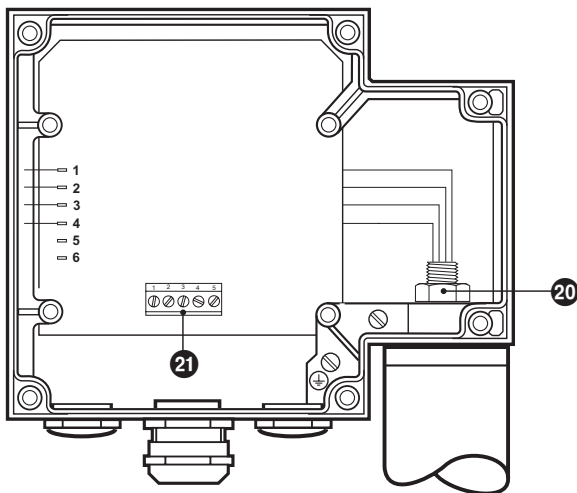

Fig. 15

Key

- 1 Measuring electrode
- 2 Bore
- 3 Spring
- 4 Electrode tip
- 5 NRG 1...-50: Joint ring 27 x 32, form D, DIN 7603, 1.4301, bright annealed
NRG 111-50: Joint ring 33 x 39, form D, DIN 7603, 1.4301, bright annealed
- 6 Seating surface
- 7 Electrode thread
- 8 Thermal insulation, provided on site, $d = 20$ mm (outside of thermal insulation of steam boiler)
- 9 Screw M 4
- 10 Cover
- 11 Upper part of the terminal box
- 12 Connecting plate
- 13 Insulating plate
- 14 Contact plate of level electrode
- 15 Cable strain relief
- 16 Cable gland M 16 (PG 9)
- 17 Housing screws M 4
- 18 Cable gland M 20 x 1.5
- 19 Housing cover
- 20 Nut
- 21 Terminal strip

Important Notes

Safety note

Water level limiters are safety devices and must only be installed, wired and commissioned by qualified and competent staff.

Retrofitting and maintenance work must only be performed by qualified staff who – through adequate training – have achieved a recognised level of competence.



Danger

When loosening the electrode steam or hot water might escape!

This presents the risk of severe scalding all over the body!

It is therefore essential not to dismantle the electrode unless the boiler pressure is verified to be 0 bar.

The electrode becomes hot during operation.

Risk of severe burns to hands and arms.

Before carrying out installation and maintenance work make sure that the steam trap is cold.



Attention

The name plate specifies the technical features of the equipment. Do not commission or operate any item of equipment that does not bear its specific name plate.



Note

For outdoor installations please use level electrode NRG 1...-50 F. Level electrodes with this suffix (F) feature a terminal box made from aluminium.

Scope of supply

NRG 16-50

- 1 Level electrode NRG 16-50, PN 40
- 1 Joint ring 27 x 32, Form D,
DIN 7603, 1.4301, bright annealed
- 1 Installation manual

NRG 17-50

- 1 Level electrode NRG 17-50, PN 63
- 1 Joint ring 27 x 32, Form D,
DIN 7603, 1.4301, bright annealed
- 1 Installation manual

NRG 19-50

- 1 Level electrode NRG 19-50, PN 160
- 1 Joint ring 27 x 32, Form D,
DIN 7603, 1.4301, bright annealed
- 1 Installation manual

NRG 111-50

- 1 Level electrode NRG 111-50, PN 320
- 1 Joint ring 33 x 39, Form D,
DIN 7603, 1.4301, bright annealed
- 1 Installation manual

Installation

NRG 16-50, NRG 17-50, NRG 19-50, NRG 111-50, step 1

1. Screw electrode tip ④ into measuring electrode ①. **Fig. 8**
2. Carefully determine required measuring length of electrode.
3. Mark length of electrode tip ④.
4. Unscrew electrode tip ④ from measuring electrode ① and cut tip.
5. After visual inspection screw electrode tip ④ into measuring electrode ①. Slide spring ③ along electrode tip ④ so that its end completely enters the small hole ②.

NRG 16-50, NRG 17-50, NRG 19-50, NRG 111-50, step 2

6. Check seating surfaces. **Fig. 12**
7. Place joint ring ⑤ onto seating surface ⑥ of the electrode. **Fig. 9**
8. Apply a light smear of silicone grease (e. g. WINIX® 2150) to electrode thread ⑦.
9. Screw level electrode into threads or flange provided on vessel and tighten with a 41 mm open-end spanner.
The torque required **when cold is 160 Nm.**

NRG 16-50 F, NRG 17-50 F, NRG 19-50 F, additional information

If one level electrode NRG 1...-50 is installed together with one level electrode, one level switch or transmitter (with aluminium terminal box) in a single protection tube or level pot, please observe the following:

1. Mount the first level electrode as specified in the pertinent installation manual.

When installing level electrode NRG 1...-50 F, please observe the following instructions:

1. Unscrew screws ⑰ and remove housing cover ⑱. **Fig. 14.** The arrow on the name plate points towards this cover..
2. Remove cable lugs from terminal lugs. **Fig. 15**
3. Loosen nut ⑳ with a 19 mm spanner, but do not remove! **Fig. 15**
4. Screw in level electrode as described in items 6 – 9.
5. Turn terminal box into desired position (+/- 180°).

The terminal box can now be turned through +/- 180°.

6. Tighten nut ⑳ with a torque of **25 Nm.**
7. Plug cable lugs onto terminal lugs.
8. Mount housing cover ⑱ and tighten screws ⑰.



Note

- **One** level electrode NRG 1...-50 can be installed together with one GESTRA level electrode, one level switch or transmitter for water level control and high level alarm in one single protection tube or level pot (inside diameter 100 mm). **Fig. 18**. If the electrode NRG 1...-50 is installed inside the vessel, it must be at least 40 mm away from the upper vent hole.
- The installation of two water-level limiting electrodes NRG 1...-50 in one single standpipe is not allowed.
- For the approval of the boiler standpipe the relevant regulations must be considered.
- Refer to pages 18 – 19 for typical installation examples.
- The angle of inclination of the electrode must not exceed 45°, with the length of the electrode rod being limited to 1000 mm. **Fig. 17, 21**
- For outdoor installations please use level electrode NRG 1...-50 F. Level electrodes with this suffix (F) feature a terminal box made from aluminium.



Attention

- The seating surfaces of the standpipe or the flange provided on the vessel must be accurately machined, see **Fig. 12**.
- If the level electrode NRG 111-50 is to be installed in a flanged standpipe DN 50 use only the GESTRA PN 160 hat flange. **Fig. 11**
- Do not bend electrode tip when mounting.
- Use only the joint rings supplied with the electrode.
NRG 16-50, NRG 17-50, NRG 19-50: 27 x 32, form D, DIN 7603, 1.4301
NRG 111-50: 33 x 39, form D, DIN 7603, 1.4301
- Do not lag electrode body above the hexagonal section!
- Do not insulate electrode thread with hemp or PTFE tape!
- Do not apply conductive paste or grease to the electrode thread!
- Make sure that the air distance between the electrode rod and earth (flange, vessel wall) is not less than 14 mm. **Fig. 11, Fig. 16-22**
- Observe the minimum distances for the installation of the electrode!

Tools

- Open-end spanner A. F. 13, DIN 3110, ISO 3318
- Open-end spanner A. F. 19, DIN 3110, ISO 3318
- Open-end spanner A. F. 41, DIN 3110, ISO 3318
- Scriber
- Hacksaw
- Flat file, medium cut, DIN 7261, form A

Examples of installation

NRG 16-50, NRG 17-50, NRG 19-50

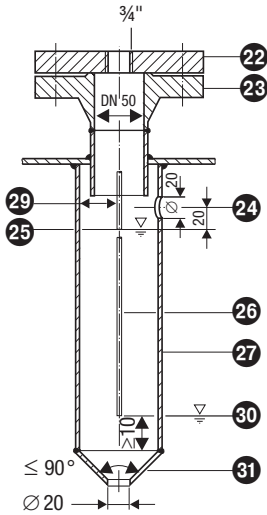

Fig. 16 Protection tube (provided on site) if electrode is used as internal water-level limiter

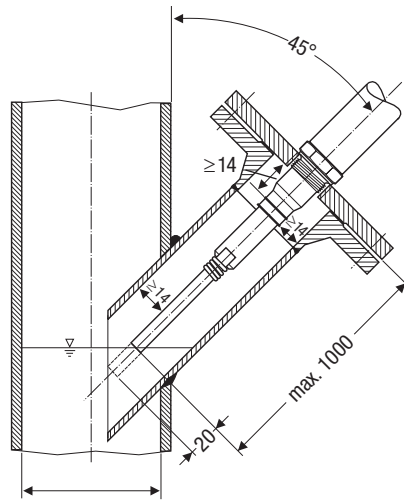

Fig. 17 Inclined installation, e. g. in ascending inlet lines of hot-water installations or vessels

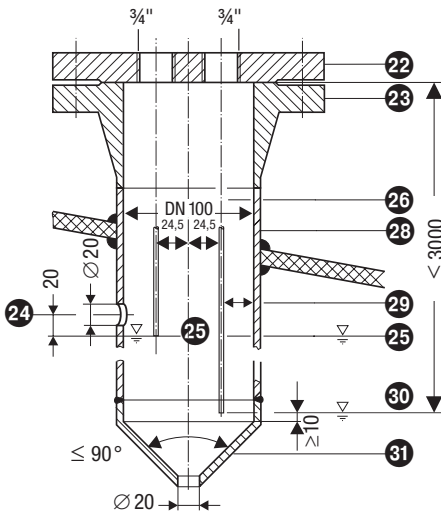

Fig. 18 Protection tube (provided on site) if electrode is used as internal water level-limiter combined with water level control or high water level alarm

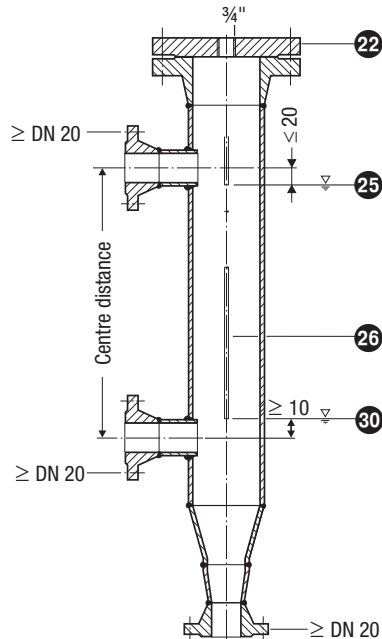

Fig. 19 Level pot if electrode is used as external water-level limiter

Examples of Installation – continued –

Key

- 22 Flange PN 40, PN 63, PN 160, DN 50, DIN 2501-1 (for one electrode)
Flange PN 40, PN 63, PN 160, DN 100, DIN 2501-1 (for two electrodes)
Flange PN 250, DN 80, DIN 2501-1 (NRG 111-50)
- 23 For the approval of the boiler standpipe with connecting flange the relevant regulations must be considered.
- 24 Vent hole Provide vent hole as close to the boiler wall as possible!
- 25 High water HW
- 26 Electrode rod $d = 8$ mm
- 27 Protection tube DN 80 (in France according to AFAQ \geq DN 100)
- 28 Protection tube DN 100
- 29 Electrode distance ≥ 14 mm (air gap and creepage distance)
- 30 Low water LW
- 31 Reducer DIN 2616-2, K-88.9 x 3.2 - 42.4 x 2.6 W

Electrical Connection

Connection of level electrode

To connect the level electrode(s) use screened multi-core control cable with a min. conductor size 0.5 mm², e.g. LiYCY 4 x 0.5 mm².

Max. length 100 m with an electrical conductivity of the boiler water > 10 µS/cm at 25 °C.

Max. length 30 m with an electrical conductivity of the boiler water < 10 µS/cm at 25 °C.

Wire terminal strip in accordance with the wiring diagram. **Fig. 21.**

Connect screens **only** to terminals 5 and 13 of the level switch NRS 1-50.

NRG 16-50, NRG 17-50, NRG 19-50, NRG 111-50, with four-pole connector

1. Undo screw **9**. **Fig. 13**
2. Remove upper part **11** of the terminal box from the level electrode but leave insulating plate **13** on contact plate **14**.
3. Remove cover **10**.
4. Press connecting plate **12** out of upper part of the terminal box **11**.
The upper part of the terminal box can be turned in steps of 90°.
5. Detach cable gland **16** and cable clamp **15** from upper part of the terminal box **11**.
6. Run cable through cable gland **16** and upper part of the terminal box **11** and wire terminals of the connecting plate **12** in accordance with wiring diagram. **Fig. 23**
7. Press connecting plate **12** into the upper part of the terminal box and align cable.
8. Fix cable with cable clamp **15** and cable gland **16**.
9. Re-attach cover **10** and insert screw **9**.
10. Put upper part of the terminal box onto the level electrode and fix it with screw **9**.

NRG 16-50 F, NRG 17-50 F, NRG 19-50 F, NRG 111-50 F, with aluminium terminal box

1. Unscrew screws **17** and remove housing cover **19**. **Fig. 14**
2. Undo cable gland **18**. Pull cable through cable entry.
3. Remove terminal strip **21** from circuit board.
4. Connect terminal strip according to the wiring diagram. **Fig. 25**
5. Attach terminal strip.
6. Tighten the cable gland in order to seal the cable entry. Use the supplied sealing plug to seal off the unused cable entry and tighten the cable gland.
7. Mount housing cover **19** and tighten screws **17**.

Wiring diagram

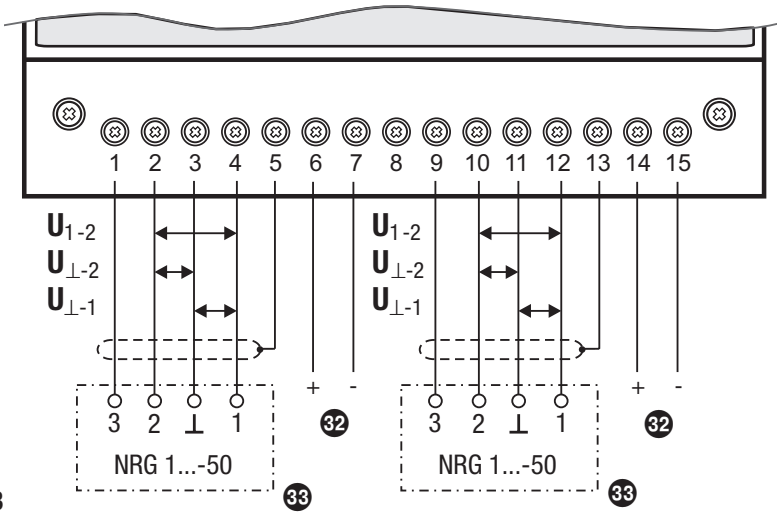

Fig. 23

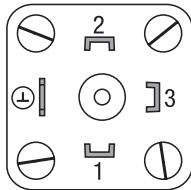

Fig. 24 Wiring of level electrode with four-pole connector

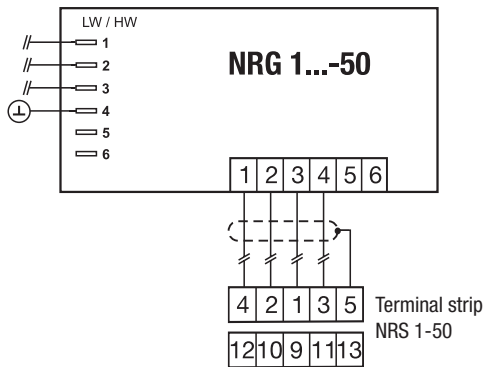

Fig. 25 Wiring of level electrode with aluminium terminal box

Electrical Connection – continued –

Key

- 32 Stand-by input 1 / 2, 24 V DC, for connecting the logic unit SRL
- 33 Level electrode NRG 1...-50

Tools

- Screwdriver for cross head screws, size 1
- Screwdriver for slotted screws, size 2.5, completely insulated according to DIN VDE 0680-1
- Open-end spanner A.F. 18 (19) mm

Commissioning, fault indication and remedy

For additional information on commissioning procedures and troubleshooting refer to the installation manual of the level switch NRS 1-50.

Decommissioning



Danger

Risk of severe burns and scalds to the whole body!
Before installing the level electrode make sure that the vessel or the external pot are depressurised (0 bar) and cooled down to room temperature (20 °C).

Disposal

Dismantle the level electrode and separate the waste materials, using the specifications in the table “Materials” as a reference.
For the disposal of the equipment observe the pertinent legal regulations concerning waste disposal.

If faults occur that are not listed above or cannot be corrected, please contact our service centre or authorized agency in your country.



GESTRA

Agencies all over the world:

www.gestra.de

España

GESTRA ESPAÑOLA S.A.

Luis Cabrera, 86-88

E-28002 Madrid

Tel. 0034 91 / 5 15 20 32

Fax 0034 91 / 4 13 67 47; 5 15 20 36

E-mail: aromero@flowserve.com

Polska

GESTRA POLONIA Spolka z.o.o.

Ul. Schuberta 104

PL - 80-172 Gdansk

Tel. 0048 58 / 3 06 10 - 02

0048 58 / 3 06 10 - 10

Fax 0048 58 / 3 06 33 00

E-mail: gestra@gestra.pl

Great Britain

Flowserve GB Limited

Abex Road

Newbury, Berkshire RG14 5EY

Tel. 0044 16 35 / 46 99 90

Fax 0044 16 35 / 3 60 34

E-mail: gestraukinfo@flowserve.com

Portugal

Flowserve Portuguesa, Lda.

Av. Dr. Antunes Guimarães, 1159

Porto 4100-082

Tel. 00351 22 / 6 19 87 70

Fax 00351 22 / 6 10 75 75

E-mail: jtavares@flowserve.com

Italia

Flowserve S.p.A.

Flow Control Division

Via Prealpi, 30

I-20032 Cormano (MI)

Tel. 0039 02 / 66 32 51

Fax 0039 02 / 66 32 55 60

E-mail: infoitaly@flowserve.com

USA

GESTRA AG

P. O. Box 10 54 60, D-28054 Bremen

Münchener Str. 77, D-28215 Bremen

Telephone 0049 (0) 421 35 03 - 0

Fax 0049 (0) 421 35 03 - 393

E-Mail gestra.ag@flowserve.com

Internet www.gestra.de

