

GESTRA Steam Systems

Product Range B1

Level Switch Type NRS 1-42 With CAN Bus

NRS 1-42

System Description

Use level switch type NRS 1-42 together with level electrode type NRG 16-42 for level monitoring. The level switch has the following functions:

- Four levels with one switchpoint each.
- High-level alarm, low-level alarm, pump ON, pump OFF with one switchpoint each.

The level data are transferred from the elec-trode NRG 16-42 to the level switch via a CAN bus.

Function

At regular intervals the level electrode NRG 16-42 sends a data signal to the level switch NRS 1-42. The data transfer is effected by means of a CAN bus according to DIN ISO 11898. The transferred measuring data are then evaluated and assigned to the manually adjusted switchpoints. A de-energizing delay of the relay can be set manually with the control terminal and display unit URB 1. To guarantee the correct functioning and safety of the system the data transmitting cycle of the level switch is constantly monitored. When the CAN bus line is interrupted the level switch sends a visual signal to indicate a malfunction and the relays 1 and 4 will be instantaneously de-energized (fail-safe position).

Design

NRS 1-42 b

Enclosure of insulating material with terminals for installation in control cabinets. The terminals are externally accessible.

Clipping onto a 35 mm standardized supporting rail (DIN EN 50022).

External dimensions: 100 x 73 x 118

CAN Bus

All level and conductivity switches, controllers and electrodes are interconnected by means of a CAN bus. The data exchange is effected by means of a CAN bus according to DIN ISO 11898 using the CANopen protocol. Every item of equipment features an electronic address (Node ID). The four-core bus cable serves as power supply and data highway for high-speed data exchange.

NRS 1-42 is configured at our works and ready for service with other GESTRA components.

NRS 1-42 can be used straight away without having to set the Node ID.

Technical Data

Type approval n°

TÜV · WR · 04-399

Input

Interface for CAN bus to DIN ISO 11898, CANopen

Output

Power supply 24 V DC, conditionally short-circuit protected. 4 volt-free relay contacts.

Max. contact rating with switching voltages of 24 V AC, 115 V AC and 230 V AC:

4 A ohmic, 0.75 A inductive at $\cos \varphi 0.5$
Max. contact rating with a switching voltage of 24 V DC: 4 A.

Contact material: silver, hard-gold plated

Relay de-energizing delay

Output "min", "max" 3 s

Indicators and adjustors

- 1 red LED for switchpoint "MAX"
- 1 red LED for switchpoint "MIN"
- 2 green LEDs for switchpoints "PUMP ON" and "PUMP OFF"
- 1 green LED "POWER ON"
- 1 red LED "Bus fault"
- 1 ten-pole code switch for node ID and baud rate
- 4 push-buttons

Supply voltage

- 230 V +/- 10 %, 50/60 Hz
- 115 V +/- 10 %, 50/60 Hz (option)
- 24 V +/- 10 %, 50/60 Hz (option)

Power consumption

5 VA

Sensitivity

- Range 1: $\geq 10 \mu\text{S/cm}$ (factory setting)
- Range 2: $\geq 0.5 \mu\text{S/cm}$

Protection

- Case: IP 40 to DIN ISO 60529
- Terminal strip: IP 20 to DIN ISO 60529

Admissible ambient temperature

0 °C to 55 °C

Enclosure material

- Front panel: polycarbonate, grey
- Case: polycarbonate, black

Weight

Approx. 0.8 kg

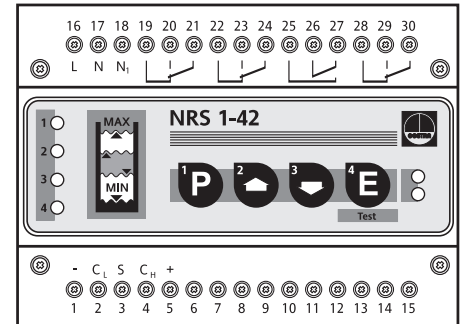

**Level Switch Type
NRS 1-42
With CAN Bus**

Important Note

Note that multi-paired control cable is required, e.g. UNITRONIC® BUS DeviceNet™ drop cable (thin) 2 x 0.25², 2 x 0.34² or RE-2YCYV-fl 2 x 2 x 0.5². Max. cable length 250 m.

To protect the switching contacts fuse circuit with T 2.5 A or according to TRD regulations 1.0 A for 72 h operation.

Order and Enquiry Specification

GESTRA Level switch type NRS 1-42 CANopen
Control equipment
Mains voltageV

Ancillary Unit

- Conductivity level electrode type NRG 16-42 CANopen

Dimensions

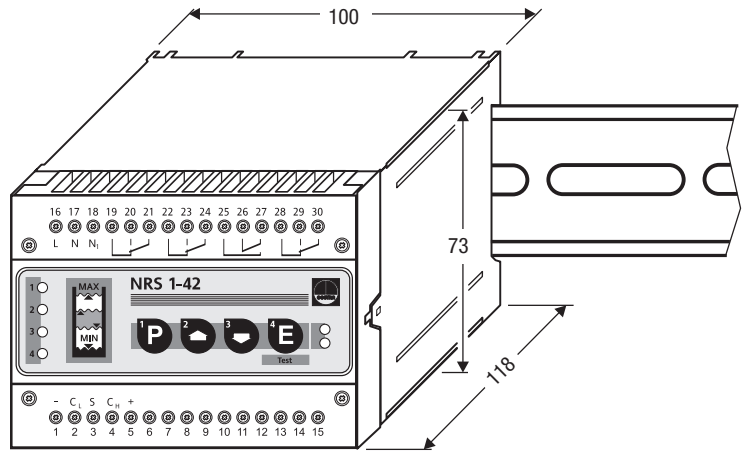
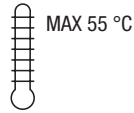

Wiring Diagram

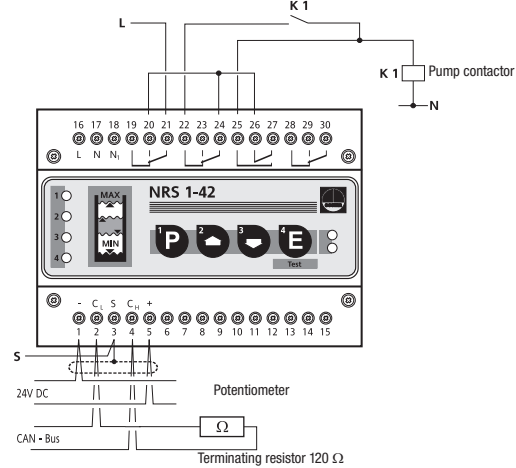

Discharge control with LOW-LEVEL cut-out function

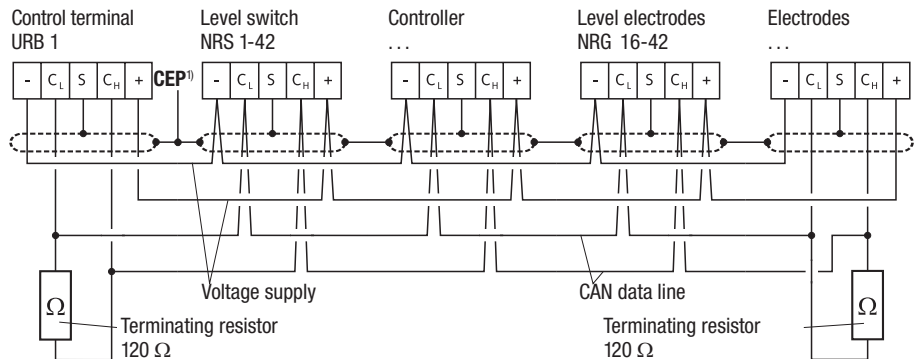
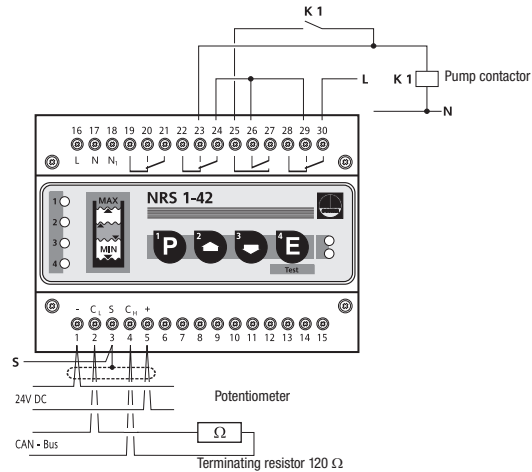

¹⁾ CEP = central earthing point

Supply in accordance with our general terms of business.

GESTRA AG

P. O. Box 10 54 60, D-28054 Bremen
Münchener Str. 77, D-28215 Bremen
Telephone +49 (0) 421 35 03 - 0, Fax +49 (0) 421 35 03-393
E-Mail gestra.ag@flowserve.com, Internet www.gestra.de

