

GESTRA Steam Systems

Product Range B1

Level Controller Type NRR 2-40 With CAN-Bus

NRR 2-40

System Description

Use level controller type NRR 2-40 in combination with level electrode type NRG 26-40 for level control and monitoring. The level controller has the following functions:

- Two level limit values with one switchpoint each (HIGH-LEVEL alarm, LOW-LEVEL alarm)
- Three-position or modulating control within a predefined proportional band
- Water level is maintained within the control band defined by the two preset limits

The NRR 2-40 features optional outputs for standard signals 4 – 20 mA.

The level data are transferred from the electrode to the level controller or an additional system component via a CAN data bus. The controller and the electrode use the CANopen protocol.

Function

At regular intervals the level electrode NRG 26-40 sends a data telegram to the level controller NRR 2-40. The data are transferred via a CAN bus to DIN ISO 11898 using the CANopen protocol. The transmitted data are then evaluated and allocated to the respective control range and switchpoints. Optionally a standard signal 4 – 20 mA is established for external level indication or, when used for modulating control, for the manipulated variable Y. A relay de-energizing delay can be set manually with the control terminal and display unit URB 1.

To guarantee the correct functioning and safety of the system the data transmitting cycle of the level controller is constantly monitored. When the CAN bus line is interrupted the level switch sends a visual signal to indicate a malfunction and the relays 1 and 4 will be instantaneously de-energized (fail safe position).

Design

NRR 2-40 b

Enclosure of insulating material with terminals for installation in control cabinets. The terminals are externally accessible. Clipping onto a 35 mm standardized supporting rail (DIN EN 50022). External dimensions: 100 x 73 x 118.

CAN Bus

All level and temperature switches, controllers and electrodes are interconnected by means of a CAN bus. The data exchange is effected by means of a CAN bus according to DIN ISO 11898 using the CANopen protocol. Every item of equipment features an electronic address (Node ID). The four-core bus cable serves as power supply and data highway for high-speed data exchange.

NRR 2-40 is configured at our works and ready for service with other GESTRA components.

NRR 2-40 can be used straight away without having to set the node ID.

Technical Data

Type approval no.

TÜV · WR · 03-399

Input

Interface for CAN bus to DIN ISO 11898, CANopen protocol
Feedback potentiometer 1000 Ω.

Output

Power supply 24 V DC, conditionally short-circuit protected.

Analogue output 4 – 20 mA, load 500 Ω for display of actual value (option).

4 volt-free relay contacts.

Max. contact rating with switching voltages of 24 V AC, 115 V AC and 230 V AC:

4 A ohmic, 0.75 A inductive at $\cos \varphi 0.5$

Max. contact rating with a switching voltage of 24 V DC: 4 A.

Contact material: silver, hard-gold plated

Interference suppression

Provide contactor with external RC combination (100 Ω-47 nF) or according to the specification of the valve manufacturer.

Analogue control output for manipulated variable 4 – 20 mA, max. load 500 Ω (option).

Relay de-energizing delay

Output "MIN", "MAX" 3s (set at the factory).

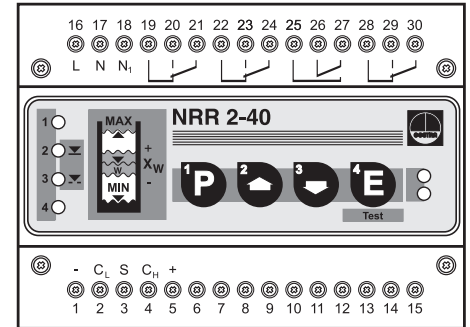

Important Note

Note that screened multi-core twisted-pair control cable is required, e. g. UNITRONIC® BUS CAN 2 x 2 x ...² or RE-2YCYV-fl 2 x 2 x ...². The bus lines in the control cabinet must be used up to the control devices.

The baud rate (data transfer rate) dictates the cable length between the bus nodes and the total power consumption of the sensor dictates the conductor size.

S 8	S 9	S 10	Baud rate	Cable length	Number of pairs and conductor size [mm ²]
OFF	ON	OFF	250 kBit/s	125 m	2 x 2 x 0.34
Factory setting					
ON	ON	OFF	125 kBit/s	250 m	2 x 2 x 0.5
OFF	OFF	ON	100 kBit/s	335 m	2 x 2 x 0.75
ON	OFF	ON	50 kBit/s	500 m	on request, dependent on bus configuration
OFF	ON	ON	20 kBit/s	1000 m	
ON	ON	ON	10 kBit/s	1000 m	

The baud rate is set via a code switch. Reduce baud rate if cable is longer than specified in the table. Make sure that all bus nodes have the same settings.

To protect the switching contacts fuse circuit with 2.5 A (anti-surge fuse) or according to TRD regulations (1.0 A for 72 hrs operation).

P.T.O.

Level Controller Type NRR 2-40 With CAN-Bus

Technical Data – continued –

Indicators and adjustors

- 1 red LED for switchpoint "HIGH LEVEL"
- 1 red LED for switchpoint "LOW LEVEL"
- 2 green LEDs for deviation
- "X_w LOW LEVEL" and "X_w HIGH LEVEL"

- 1 green LED "Power"
- 1 red LED "Bus fault"
- 1 ten-pole code switch for node ID and baud rate
- 4 pushbuttons

Control response

P-controller as continuous or three-position stepping controller

Proportional band X_p

1 % to 100 %

Position feedback Y_p

0 Ω to 1000 Ω

Switching range (dead band) X_{Sn}

3 %

Supply voltage

- 230 V +/- 10 %, 50/60 Hz
- 115 V +/- 10 %, 50/60 Hz (option)
- 24 V +/- 10 %, 50/60 Hz (option)

Power consumption

5 VA

Protection

- Enclosure: IP 40 to DIN EN 60529
- Terminal strip: IP 20 to DIN EN 60529

Admissible ambient temperature

0 °C to 55 °C

Enclosure material

- Front panel: polycarbonate, grey
- Enclosure: polycarbonate, black

Weight

Approx. 0.8 kg

Order and Enquiry Specification

GESTRA Level Controller type NRR 2-40 CANopen

Mains voltageV

Ancillary Units

- Capacitance level electrode type NRG 26-40 CANopen
- Control terminal and display unit type URB 1 CANopen

Supply in accordance with our general terms of business.

Dimensions

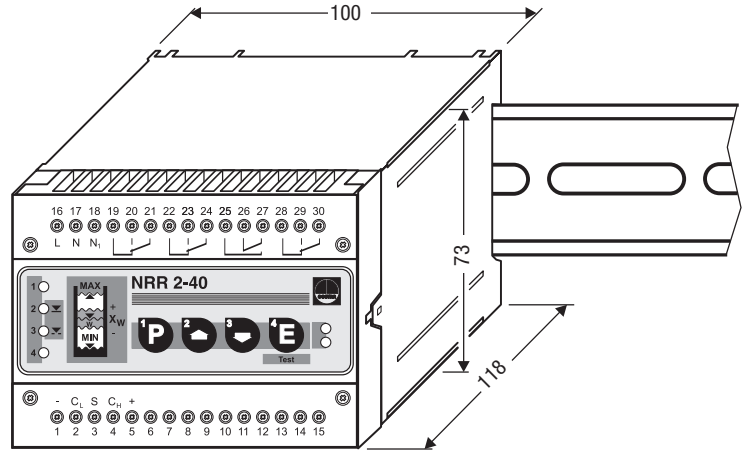
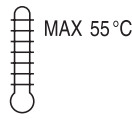

Wiring Diagram

Three-position stepping controller

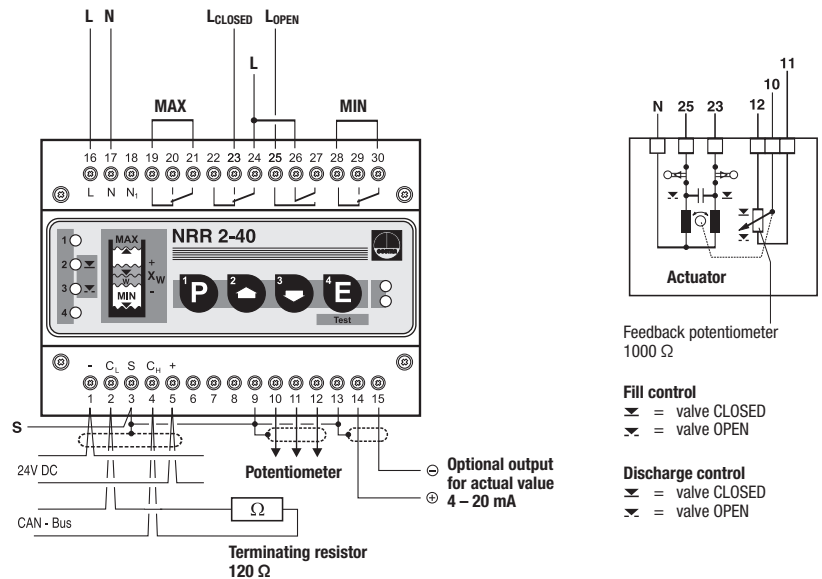

Continuous controller

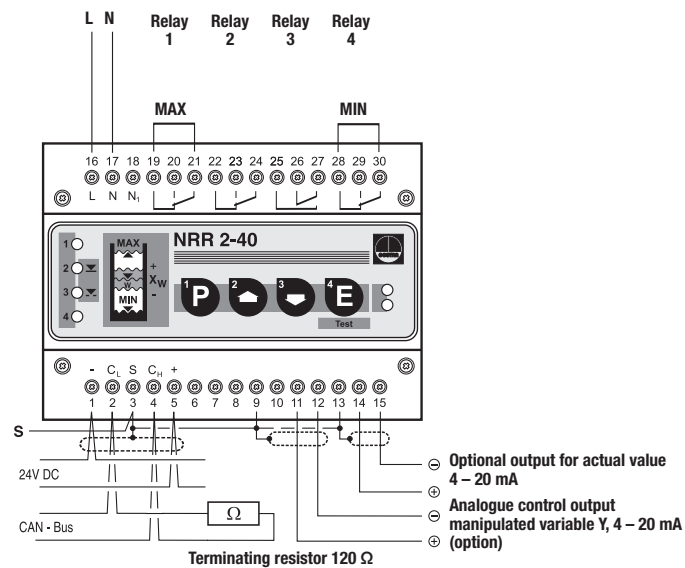

GESTRA AG

P. O. Box 10 54 60, D-28054 Bremen
 Münchener Str. 77, D-28215 Bremen
 Telephone +49 (0) 421 35 03 -0, Fax +49 (0) 421 35 03-393
 E-Mail gestra.ag@flowsolve.com, Internet www.gestra.de



GESTRA