

## GESTRA Steam Systems

## Product Range B

### Level Electrode With CAN Bus, CANopen Protocol Type NRG 16-42

### NRG 16-42

#### System Description

The level electrode operation is based on the conductive measuring principle. The NRG 16-42 is designed for signalling max. four liquid levels in electrically conductive liquids:

- 4 levels with **one** switchpoint each
- High-level alarm, low-level alarm, pump ON, pump OFF with **one** switchpoint each.

Use level electrode NRG 16-42 in conjunction with level switch NRS 1-42 or other system components. The level data are transferred from the the electrode to the level switch or an additional system component via CAN data bus, using the CANopen protocol.

#### Function

The conductivity of the liquid is used to signal the liquid level. Some liquids are conductive, which means that they allow an electric current to flow through them. For the safe functioning of this device a minimum conductivity of the liquid to be measured is required.

The conductivity measurement method can detect two conditions: electrode rod submerged or exposed, meaning switchpoint reached (or exceeded) or not yet reached. Before installation, the length of the electrode rod must be cut to the required switching level, e. g. for limit alarms, valve/pumps on/off etc.

At regular intervals the level electrode NRG 16-42 sends a data telegram to the switching controller NRS 1-42. The data are transferred via a CAN bus to DIN ISO 11898 using the CANopen protocol.

#### Design

NRG 16-42 screwed 1" BSP, EN ISO 228-1

#### Technical Data

**Type Approval n°**  
TÜV · WR · 04-399

**Max. service pressure**  
32 barg at 238 °C

**Connections**  
Screwed 1" BSP, EN ISO 228-1  
Flanged DN 50, PN 40, DIN 2635

**Materials**  
Terminal box: Die cast aluminium 3.2161 (G AISi8Cu3)  
Stem: S. S. 1.4571 (X6CrNiMoTi17-12-2)  
Measuring electrodes: S. S. 1.4401 (X5CrNiMo17-12-2)  
Electrode insulation: PEEK  
Spacer disk: PTFE

**Lengths supplied**  
500 mm  
1000 mm  
1500 mm

**Supply voltage**  
18 – 36 V DC

**Current consumption**  
65 mA

**Fuse**  
Thermal fuse  $T_{max} = 85 °C$

**Hysteresis**  
-2 K

**Electrode voltage**  
10  $V_{SS}$

**Data exchange**  
CAN bus to DIN ISO 11898, CANopen protocol

P.T.O.

#### Important Note

Note that screened multi-core twisted-pair control cable is required, e. g. UNITRONIC® BUS CAN 2 x 2 x ... mm<sup>2</sup> or RE-2YCYV-fl 2 x 2 x ... mm<sup>2</sup>.

Prefabricated control cables (with connector and coupler) of various lengths for connecting the equipment are available as accessories.

The baud rate (data transfer rate) dictates the cable length between the bus nodes and the total power consumption of the sensor dictates the conductor size.

S 8	S 9	S 10	Baud rate	Cable length	Number of pairs and conductor size [mm <sup>2</sup> ]
OFF	ON	OFF	250 kBit/s	125 m	2 x 2 x 0.34
<b>Factory setting</b>					
ON	ON	OFF	125 kBit/s	250 m	2 x 2 x 0.5
OFF	OFF	ON	100 kBit/s	335 m	2 x 2 x 0.75
ON	OFF	ON	50 kBit/s	500 m	on request, dependent on bus configuration
OFF	ON	ON	20 kBit/s	1000 m	
ON	ON	ON	10 kBit/s	1000 m	

The baud rate is set via a code switch. Reduce baud rate if cable is longer than specified in the table. Make sure that all bus nodes have the same settings.

To protect the switching contacts fuse circuit with 2.5 A (anti-surge fuse) or according to TRD regulations (1.0 A for 72 hrs operation).

**Note: If the cable is longer than 125 m (max. 1000 m!) the baud rate must be changed.**

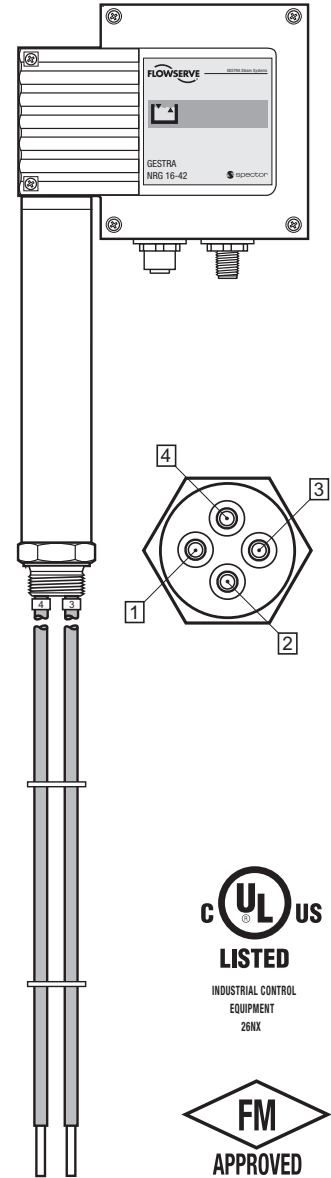

#### Wiring Diagram

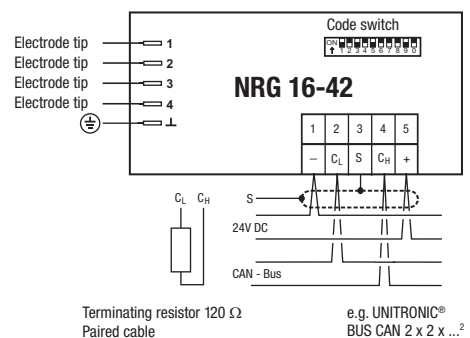

Terminating resistor 120  $\Omega$   
Paired cable e.g. UNITRONIC® BUS CAN 2 x 2 x ...<sup>2</sup>

# Level Electrode With CAN Bus, CANopen Protocol Type NRG 16-42

## Technical Data – continued –

### Indicators and adjustors

- 1 green LED for indication "COMMUNICATION CAN BUS"
- 1 red LED "BUS FAULT"
- 1 10-pole code switch for node ID and baud rate settings

### Electric connection

- M 12 sensor connector, 5 poles, A-coded,
- M 12 sensor jack, 5 poles, A-coded

### Protection

IP 65 to DIN EN 60529

**Max. admissible ambient temperature**  
70 °C

### Weight

approx. 2.5 kg

## Order and Enquiry Specification

GESTRA Level electrode type NRG 16-42

## Associated Switching Controller

- Level switch type NRS 1-42

## Ancillary Unit

- Visual display unit type URB 1, URB 2

## Key

- A** Flange PN 40, DN 50, DIN ISO 2527  
Flange PN 40, DN 100, DIN ISO 2527
- B** For the approval of the boiler standpipe with connecting flange the relevant regulations must be considered.
- C** Vent hole
- D** High water (HW)
- E** Electrode rod d = 15 mm
- F** Protection tube DN 80 mm
- G** Electrode distance
- H** Low water (LW)
- I** Reducer K-88.9 x 3.2 – 42.4 x 2.6 W
- M** Lengths supplied  
500 mm  
1000 mm  
1500 mm

## ATEX (Atmosphère Explosible)

According to the European Directive 94/9/EC the equipment must **not** be used in explosion-risk areas.

Supply in accordance with our general terms of business.

## Dimensions

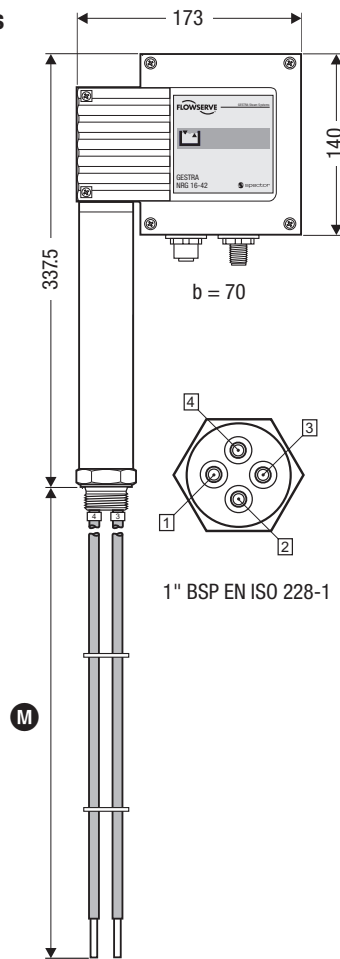

Fig. 1 NRG 16-42

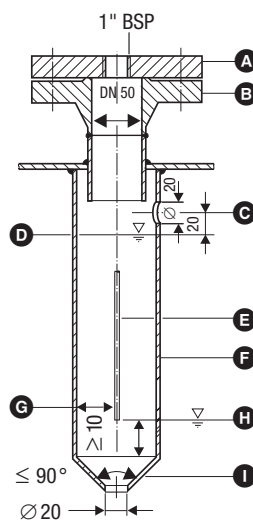

Fig. 2 Protection tube for installation of electrode inside the boiler

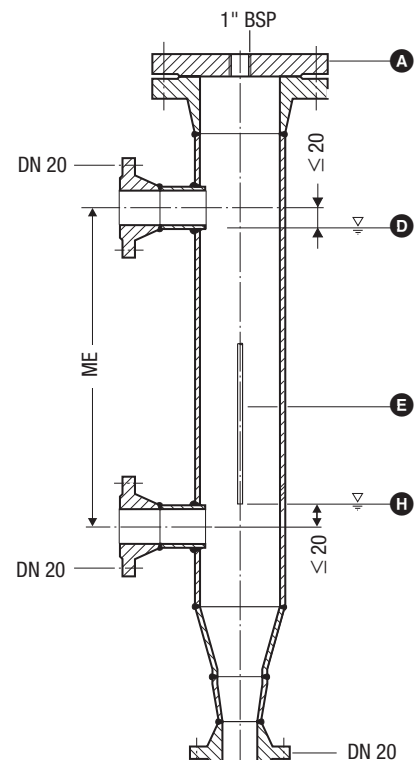
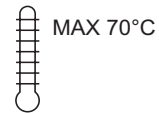

Fig. 3 External measuring pot



# GESTRA AG

P. O. Box 10 54 60, D-28054 Bremen  
Münchener Str. 77, D-28215 Bremen  
Telephone +49 (0) 421 35 03 - 0, Fax +49 (0) 421 35 03-393  
E-Mail gestra.ag@flowsolve.com, Internet www.gestra.de



GESTRA