

# GESTRA Steam Systems

## Product Range Group C4

### Mixing Cooler VDM

### VDM

#### Pressure / Temperature Rating

Max. service pressure	..... 1 bar g
	..... 14.5 psi g
Max. temperature	..... 120 °C

#### Materials

Steel DIN reference: St 37-2  
(ASTM equivalent: A 283 Grade C).  
Austenitic stainless steel on request.

#### Application

Mixing coolers are used to cool hot waste water that can no longer be used for heat recovery and is therefore discharged into a pit or drain.

Typical applications are, for example: process plants where contaminated, hot waste water is being formed, steam boiler plants where the blowdown is cooled with untreated water, mixing cooler for vapours.

When the VDM is used to cool the blowdown from a steam boiler, addition of cooling water may cause the formation of sludge by precipitation of carbonates. This can be avoided by flushing regularly, and if necessary by the addition of acid.

#### Capacity Range

Standard design for hot-water flowrates of up to 15 t/h. Higher flowrates on request.

#### Supply

1. Vessel without equipment.
2. Vessel with equipment, but supplied separately.

#### Design

The mixing coolers are made of 5 mm steel plate in welded construction. The inside is untreated, the outside provided with an antirust paint. The equipment is supplied with all necessary connections and supports.

On request: Additional cooling-water spray nozzle, vessel made of austenitic stainless steel.

#### Connections

Flanged to DIN PN 16.

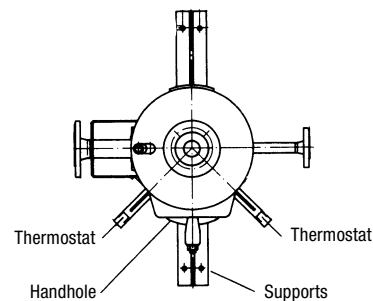
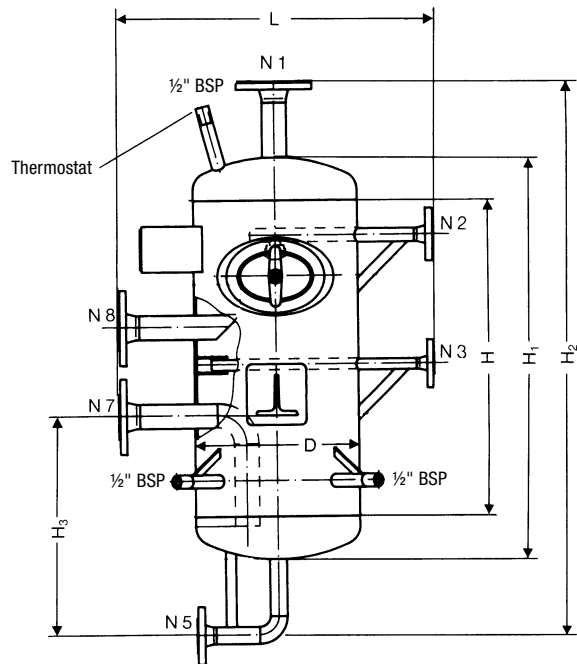

Hot-water flowrate	[t/h] *)	0.3	0.6	1.5	3	5	8.5	15
Volume	l	50	100	250	390	850	1370	2100
Dimensions [mm]	D	324	400	600	600	800	1000	1200
	H	625	625	700	1200	1450	1450	1450
	H <sub>1</sub>	795	825	980	1480	1806	1882	1960
	H <sub>2</sub>	1095	1125	1278	1778	2106	2182	2260
	H <sub>3</sub>	435	450	490	690	928	966	1005
	L	624	700	900	900	1100	1300	1500
N8 Hot-water inlet	DN	40	40	40	65	100	100	150
N7 Mixed-water outlet	DN	40	40	80	100	150	200	200
N1 Vent	DN	40	40	80	100	150	200	300
N3 Cooling-water inlet	DN	15	15	20	25	40	50	50
N2 Cooling-water inlet	DN	on request						
N5 Drain	DN	25	25	25	40	40	40	80
Materials		Steel – DIN reference: St 27-2 (ASTM equivalent: A 283 Grade C)						
Approx. weight	[kg]	85	95	105	140	250	340	420

\*) When considering the use of the VDM as a blowdown receiver, it is essential to take account of the maximum possible flowrates from all blowdown valves connected to the VDM.

# Mixing Cooler VDM

## Description

The hot waste water is discharged into the mixing cooler which is at atmospheric pressure and passes over the rod feeler of the thermostat. The cooling water enters via a solenoid valve, the amount depending on the temperature setting of the thermostat.

If the waste water is discharged from a system under pressure with a temperature above 100 °C – e. g. boiler blowdown – flash steam is formed.

If the flash steam can neither be recovered or discharged to atmosphere, (because of the inconvenience caused by the condensing steam), it can be condensed inside the mixing cooler. This is performed by a second cooling-water spray nozzle fitted in the upper part of the cooler. In this case the cooling-water supply is controlled by a solenoid valve triggered either by the blowdown valve simultaneously with the blowdown process or by a thermostat fitted in the upper part of the mixing cooler.

When the VDM is used as an intermittent or continuous blowdown receiver, the vessel must be checked for the formation of scale and sludge. Sludge should be removed by flushing with clean water; scale can be removed with an acid cleaner.

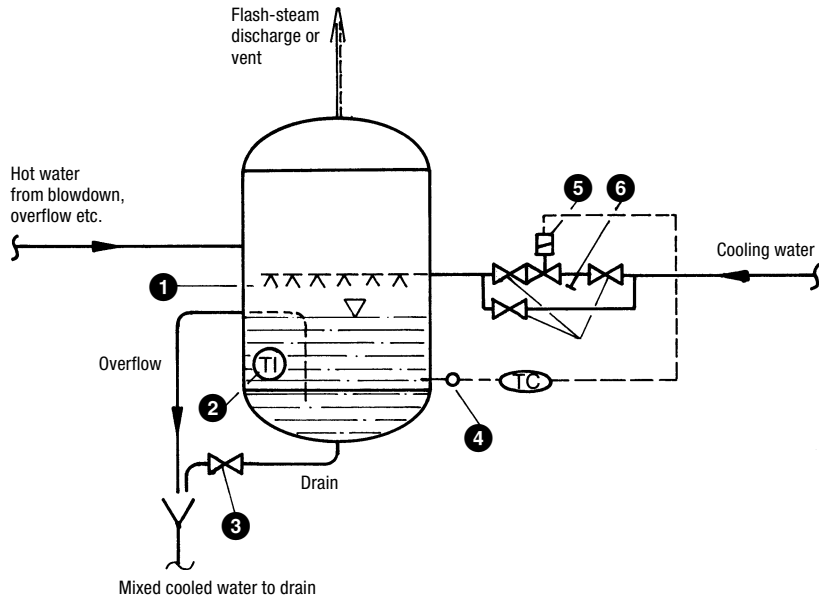

Fig. 1: Mixing cooler with cooling-water control

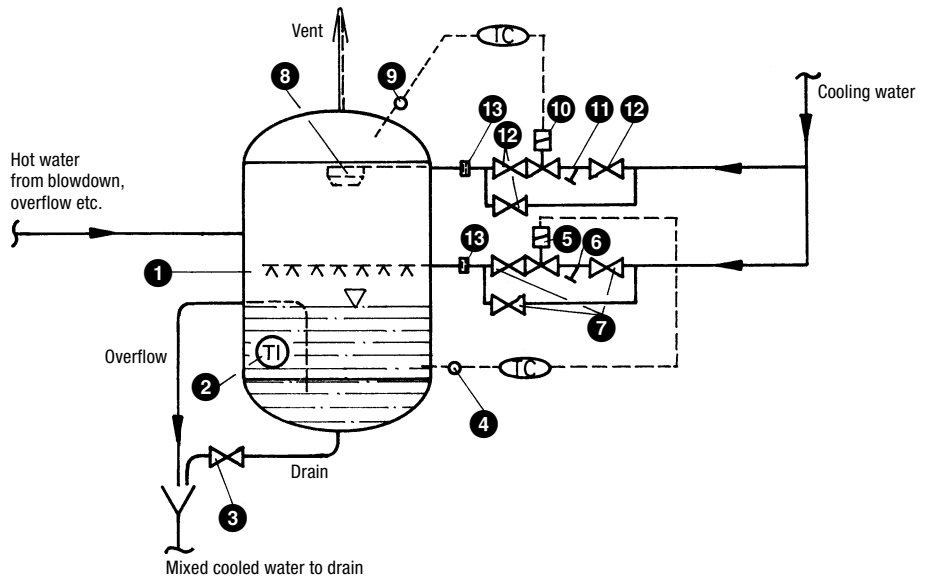

Fig. 2: Mixing cooler with cooling-water control and additional flash-steam condensation

- 1 = Mixing cooler
- 2 = Dial thermometer
- 3 = Isolating valve
- 4 = Thermostat
- 5 = Solenoid valve
- 6 = Strainer
- 7 = Isolating valve
- 8 = Spray nozzle
- 9 = Thermostat
- 10 = Solenoid valve
- 11 = Strainer
- 12 = Isolating valve
- 13 = DISCO non-return valve

Supply in accordance with our general terms of business.

## GESTRA AG

P. O. Box 10 54 60, D-28054 Bremen  
Münchener Str. 77, D-28215 Bremen

Telephone +49 (0) 421 35 03 -0, Fax +49 (0) 421 35 03 - 393

E-Mail [gestra.ag@flowserve.com](mailto:gestra.ag@flowserve.com), Internet [www.gestra.de](http://www.gestra.de)

