

<b>USERS MANUAL</b>		<b>Edition: 1/2008</b> <b>Date: 01.01.2008</b>
<b>Bellow sealed valve</b>	<b>Fig.229, Fig.230, Fig.234,235</b>	<i>Manufacturer: ZATKAMA S.A</i> <i>Ścinawka Średnia ul 3 Maja 12</i>

## CONTENTS

1. Product description
2. Requirement for maintenance staff
3. Transport and storage
4. Function
5. Application
6. Assembly
7. Maintenance
8. Service and repair
9. Reasons of operating disturbances and remedy
10. Warranty terms



## - PRODUCT DESCRIPTION

	<b>figure 229</b> ends flange form straight		<b>figure 230</b> ends flange form angle		<b>figure 234</b> ends flange form straight		<b>figure 235</b> ends flange form angle
---	---	---	--	---	---	---	--

Bellow sealed globe valves are manufactured at different executions, they are used as stop valves and throttling valves. Stop valves are designed only for shut off and open the flow, throttling valves are designed for flow control.

Stem sealing is performed by flexible bellow and additional protecting gland.

Bellow sealed valves are provided with casted marking according to requirements of PN-EN19 standard. The marking facilitates technical identification and contains:

- diameter nominal DN (mm),
- pressure nominal PN (bar),
- body and bonnet material marking,
- arrow indicating medium flow direction,
- manufacturer marking,
- heat number,
- 7. CE marking, for valves subjected 97/23/EC directive. CE marking starts from DN32

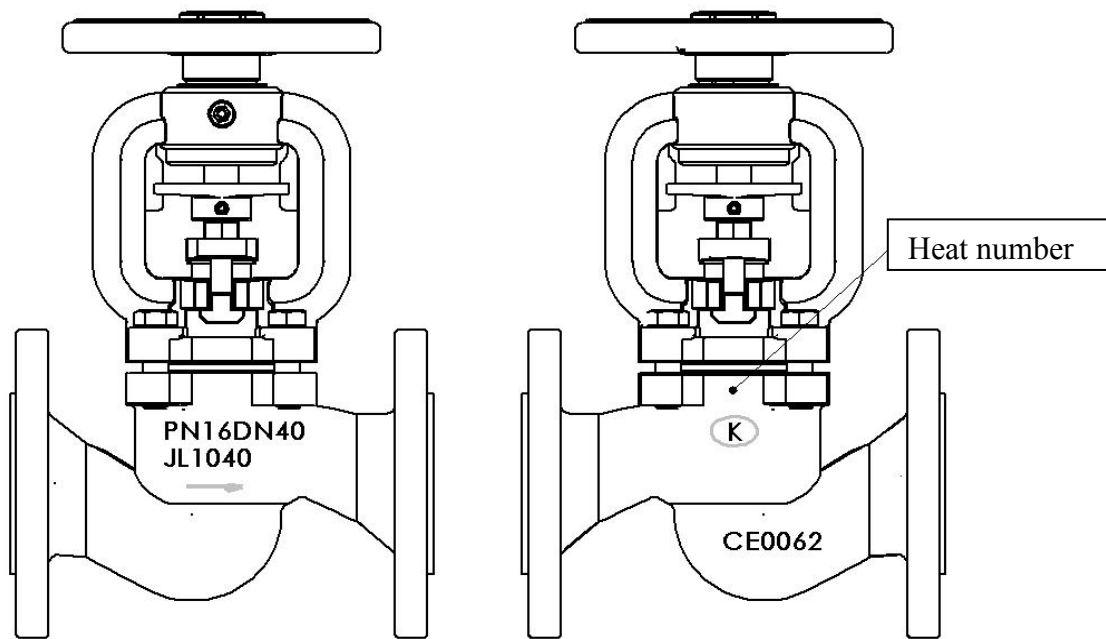

**- REQUIREMENTS FOR MAINTENANCE STAFF**

The staff assigned to assembly, operating and maintenance tasks should be qualified to carry out such jobs. If the valve is provided with mechanical actuators, operating manual of actuator should be obeyed. If during valve operation heat parts of the valve, for example handwheel, body or bonnet parts could cause burn, user is obliged to protect them against touch.

**3. TRANSPORT AND STORAGE**

Transport and storage should be carried out at temperature from  $-20^{\circ}\text{C}$  to  $65^{\circ}\text{C}$ , and valves should be protected against external forces influence and destruction of painting layer as well. The aim of painting layer is to protect the valves against rust during transport and storage. Valves should be kept at unpolluted rooms and they should be also protected against influence of atmospheric conditions. There should be applied drying agent or heating at damp rooms in order to prevent condensate formation. The valves should be

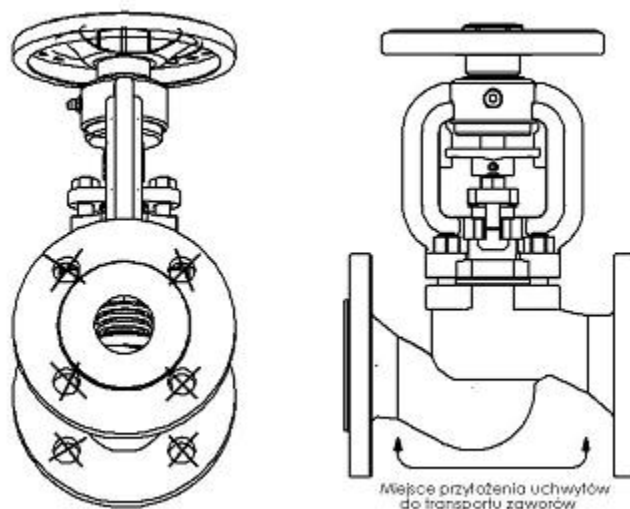

transported in such a way to avoid handwheel and valve stem damage.

**It is not allowed to fit lifting devices to connecting holes and handwheel.**

#### 4. FUNCTION

Valves with stop disc are designed for shut off medium flow, valves with throttling disc enable to control the flow. Application range was mentioned at catalogue card. The kind of working medium makes some materials to be use or to be prohibited for use. Valves were designed for normal working conditions. In the case that working conditions exceed these requirements (for example for aggressive or abrasive medium) user should ask manufacturer before placing an order. When selecting the valve for specific medium, "List of Chemical Resistance" can be helpful. It can be found at manufacturer website near catalogue cards. Working pressure should be adapted to maximum medium temperature according to the table as below.

Acc to EN 1092-2		Temperature [° C]					
Material	PN	-10 up to 120	150	200	250	300	350
EN-GJL250	16	16 bar	14,4 bar	12,8 bar	11,2 bar	9,6 bar	-----
EN-GJS400-18 LT	16	16 bar	15,5 bar	14,7 bar	13,9 bar	12,8 bar	11,2 bar
EN-GJS400-18 LT	25	25 bar	24,3 bar	23 bar	21,8 bar	20 bar	17,5 bar

Acc to EN 1092-1		Temperature [° C]									
Material	PN	from -60 up to -10	-10 up to 120	100	150	200	250	300	350	400	450
GP240GH	40	30 bar	40 bar	37,3 bar	34,7 bar	30,2 bar	28,4 bar	25,8 bar	24 bar	23,1 bar	22,2 bar



**Plant designer is responsible for valve selection suitable for working conditions.**

#### 5. APPLICATION

- steam plants
- thermal oil plants ( fig.234 )
- industrial technologies, power industry

#### 6. ASSEMBLY

During the assembly of balancing valves following rules should be observed:

- to evaluate before an assembly if the valves were not damaged during the transport or storage and to make sure that applied valves are suitable for working conditions and medium used in the plant,
- to take off dust caps if the valves are provided with them,
- to protect the valves during welding jobs against splinters and used plastics against excessive temperature,
- steam pipelines should be fitted in such a way to avoid condensate collection; in order to avoid water hammer steam trap should be applied



**Pipeline where the valves are fitted should be conducted and assembled in such a way that the valve body is not subjected to bending moment and stretching forces.**

**Bolted joints on the pipeline must not cause additional stress resulted from excessive tightening, and fastener materials must comply with working conditions of the plant,**

- during pipeline painting valve stem should be protected,
- valves can be assembled in any position, however it is recommended to install the valve with handwheel upwards,



**It should be take note of medium flow direction, marked with an arrow on the body and flow direction is established by the followings rules:**

Stop valve	Throttling valve	Stop valve
PN6 – PN25	PN16 – PN25	PN40

<b>Under the disc</b>	DN15 DN150	-	DN15 – DN200	DN15 – DN100
<b>On the disc</b>	DN200 DN250	-	-	DN125 – DN200

- before plant startup, especially after repairs carried out, flash out the pipeline through entirely open valve, in order to avoid solid particles or welding splinters which may be harmful for sealing surfaces,
- strainer ( wire mesh filter) installed before the valve increases certainty of its correct action.

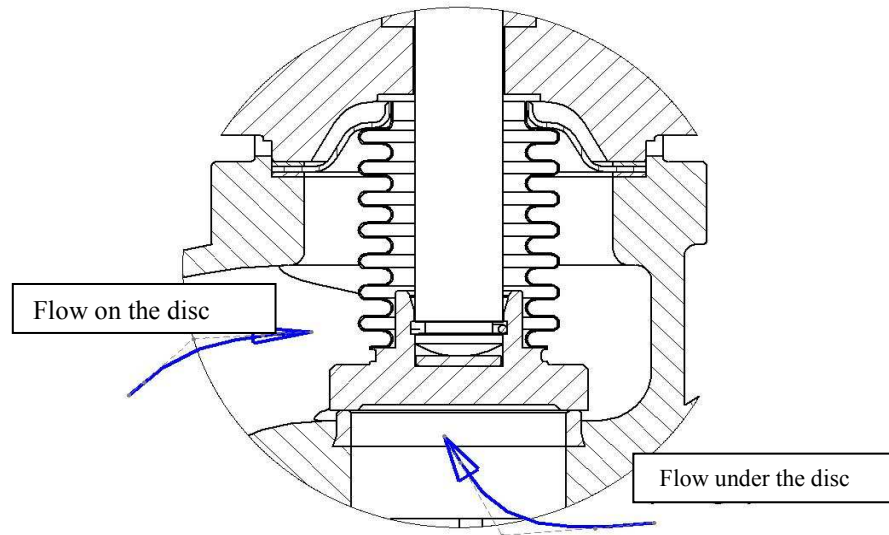

## 7. MAINTENANCE

During maintenance following rules should be observed:

- startup process – sudden changes of pressure and temperature should be avoided when starting the plant,
- valve is closed by turning the handwheel clockwise when looking from above the handwheel (according to direction marked on the handwheel), arrow
- valve is opened by turning the handwheel counter-clockwise.

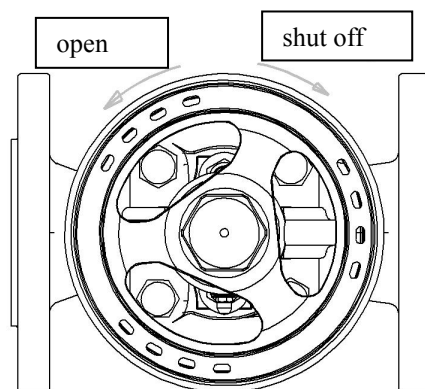

**It is prohibited to use additional lever when turning the handwheel**

- performance of fitted valves can be checked by multiple closing and opening,
- if necessary gland packing should be tighten and packing rings should be added in advance,

- if leakage on stem occurs in valves Fig.234, 235 it is necessary to tighten with moderate force two T-bolt nuts pressing the packing gland until the leakage disappear, whereas for valves Fig.229 i 230 packing rings are pressed by tightening threaded gland screwed in the bonnet.

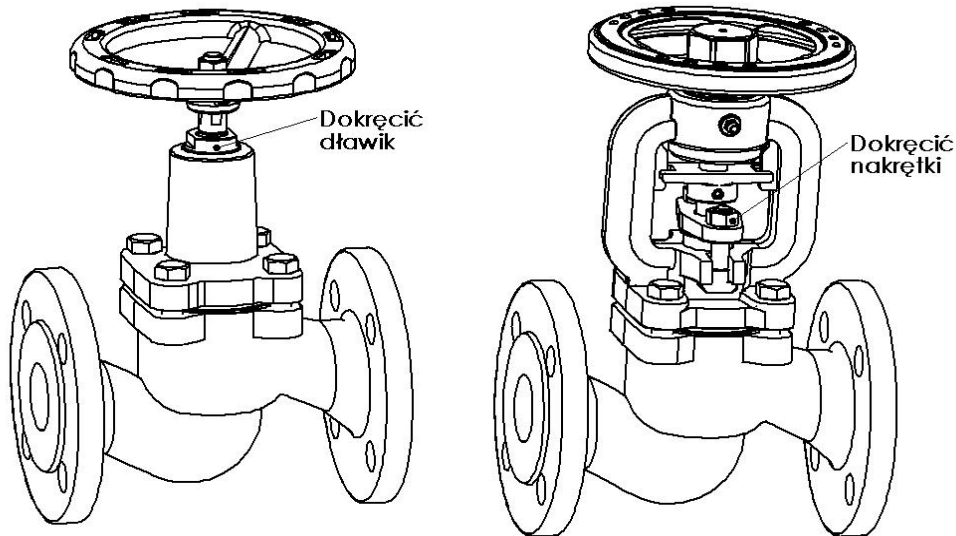

**!** Leakage on the gland packing means that bellow was damaged. Upper part of the valve should be replaced immediately

**!** In order to assure safety performance (rarely used) should be surveyed on regular basis. Inspection frequency should be laid down (tighten threaded gland in one time per month. tighten the nuts)

#### 8. SERVICE AND REPAIR

All service and repair jobs should be carried out by authorized staff using suitable tools and original spare parts. Before disassembly of complete valve from the pipeline or before service, the pipeline should be out of operation. During service and repair jobs it is necessary to decrease pressure to 0 bars, valve temperature to ambient temperature and to use personal health protectives in pursuance of existing threat. After valve disassembly it is necessary to replace flange connection gaskets between valve and pipeline

**!** Precautions should be taken when touching gasket between body and valve bonnet. The gasket contains stainless steel stripe that may cause injury,

Everytime when valve bonnet was disassembled sealing surface should be cleaned. During assembly it should be applied new gasket of the same type as previously used. Body-bonnet bolt connections should be tighten when the valve is at open position. The bolts should be tighten evenly and crosswise by torque wrench.

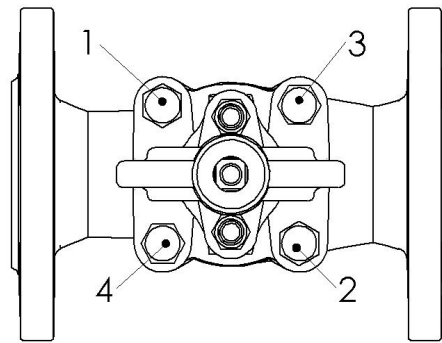

9. Tighten torques

Screw	Torque
M8	15-20 Nm
M10	35 -40 Nm
M12	65 – 70 Nm
M16	140 -150 Nm

- before valves re-assembly in the pipeline it is necessary to check valve operation and tightness of all connections. Tightness test should be carried out with water pressure of 1,5 nominal pressure of the valve.

**9. REASONS OF OPERATING DISTURBANCES AND REMEDY**

5. When seeking of valve malfunction reasons safety rules should be strictly obeyed

<b>Fault</b>	<b>Possible reason</b>	<b>Remedy</b>
No flow	Valve closed	Open the valve
	Flange dust caps were not removed	Remove dust caps on the flanges
Poor flow	Valve is not open enough	Open the valve
	Dirty filter	Clean or replace the screen
	Clogged pipeline	Check the pipeline
Control difficulties	Dry stem	Grease the stem
	Gland packing tighten too much	Slightly slacken gland nuts. Put attention to keep stuffing box tightness
Stem leakage	Bellow damage	Tighten the gland until tightness will be reached. Replace upper part of the valve as soon as possible.

Seat leakage	Shut off not correct	Tighten the handwheels without any auxiliary tools
	Seat or disc damage	Replace the valve and contact supplier or manufacturer
	Pressure difference too much	Apply valve with balancing disc. Check if the valve was assembled according to arrow direction marked on the valve.
	Medium polluted with solid particles	Clean the valve. Fit strainer before the valve.
Broken connecting flange	Bolts tighten unevenly	Replace the valve with new one

## 10. WARRANTY TERMS

- ZETKAMA grants quality warranty with assurance for proper operation of its products, providing that assembly of them is done according to the users manual and they are operated according to technical conditions and parameters described in ZETKAMA's catalogue cards. Warranty period is 18 months starting from assembly date, however not longer than 24 months from the sales date.

- warranty claim does not cover assembly of foreign parts and design changes done by user as well as natural wear.

- immediately after detection the user should inform ZETKAMA about hidden defects of the product

- a claim should be prepared in written form.

Address for correspondence :

ZETKAMA S.A.  
 ul. 3 Maja 12 57-410 Ścinawka Średnia  
 Phone (0048) (74) 8652100  
 Fax (0048) (74) 8652101  
 Website: [http:// www.zetkama.com.pl](http://www.zetkama.com.pl)