

# Rückschlagklappen aus Stahlguss

## Swing check valves of cast steel

# RAMSEYER

INDUSTRIESTRASSE 32 CH-3175 FLAMATT

- Ausführung:** Rückschlagklappen aus Stahlguss mit druckdichtendem Deckel, Class 1500–2500, Size 2''–20''
- Design:** Swing check valves of cast steel with pressure sealed cover, Class 1500–2500, Size 2''–20''
- Standards:** Ausführung / Design: ANSI B16.34 & BS 1868  
 Prüfung / Testing: API 598  
 Baulänge face-to-face dimension: ANSI B16.10  
 Flansche / Flanged ends: ANSI B16.5  
 Schweissenden / Butt weld ends: ANSI B16.25
- Werkstoffe (Gehäuse):** WCB, WC1, WC6, WC9, LCB, LCC, LC3, C5, C12,  
**Materials (Body):** CF8, CF8M, CF3, CF3M, CF8C, ...
- Werkstoffe (Einbauteile):** 13%Cr, 304, 304L, 316, 316L, 321, 347,  
**Materials (Trims):** F-51, Monel, ...

Class		1500											
Size	[inch]	2''	3''	4''	6''	8''	10''	12''	14''	16''	18''	20''	
dn	[mm]	47	70	92	136	178	222	263	289	330	371	476	
A	[mm]	216	305	406	559	711	864	991	1067	1194	1537	1664	
B	[mm]	207	255	270	345	400	495	605	650	715	785	870	
<b>Gewicht</b> <b>Weight</b>	SE* bwe*	[kg]	24	44	80	230	343	620	950	1675	2570	3800	5400

Class		2500											
Size	[inch]	2''	3''	4''	6''	8''	10''	12''	14''	16''	18''	20''	
dn	[mm]	38	57	73	111	145	184	219	241	276	311	343	
A	[mm]	279	368	457	610	762	914	1041	1118	1245	1397	1575	
B	[mm]	275	295	336	420	490	585	700	785	887	1050	1200	
<b>Gewicht</b> <b>Weight</b>	SE* bwe*	[kg]	41	75	150	305	570	734	1250	1950	3200	5500	8920

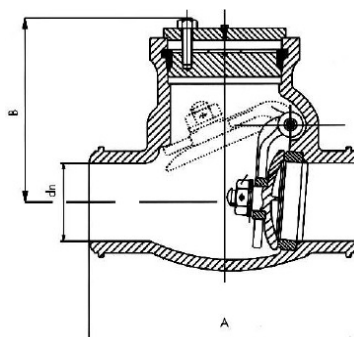

Fig. 950-05

\*SE = Schweissenden / bwe = butt welding ends

Abweichungen bei Verwendung anderer Anschlüsse möglich  
 Changes possible using other connections

### Merkmale:

- Mit druckdichtendem Deckel
- Flanschform RF und RTJ, Schweissenden
- Dichtring geschraubt (wechselbar), eingeschweisst
- Betätigung: Handrad, Getriebe, elektrisch, pneumatisch, hydraulisch

### Features:

- With pressure sealed cover
- Flange raised face RF and RTJ, butt weld ends
- Seat rings threaded (renewable), welded
- Operation: Handwheel, gear, electric, pneumatic, hydraulic

### Auf Anfrage:

- Fig. 950-04 mit Class 600–900 und Size 2''–30''

### On demand:

- Fig. 950-04 with Class 600–900 and Size 2''–30''

## Rückschlagklappen aus Stahlguss mit druckdichtendem Deckel

### Swing check valves of cast steel with pressure sealed cover

Class 1500–2500 Size 2''–20''

Fig. 950-05